

# COMPALARM A

## GENERAL

The system is composed by:

- 1) Alarm card
- 2) Power supply and flashing card
- 3) Relay card
- 4) Timing card
- 5) Card holder unit
- 6) Power transformers and Dc/Dc converters
- 7) Signalling cells, SQ type (with LED on request)

It's available in 2 different executions:

- The first one being supplied with its various components unassembled, but fitted with their corresponding wiring terminals.
- The second is being supplied as a prewired solution in a flush mounting rack.

The first solution is the most versatile either for assembling or displaying.

As far as its operation is concerned, the alarm unit (optical and acoustic signalling) is excited, when its input contact changes its status ( i.e. When it changes from open or normal condition to close or alarm condition). The alarm action behaviour follows the detailed patterns given in the ISA selection table, at the page 5, according with the selected sequence. The system is also fitted with terminals for wiring external push-buttons for:

- **Sequence test, in order to control the system's efficiency.**
- **Acknowledge, in order to intervene on the siren during its normal operation.**
- **For resetting the cards, which memorize the tripping of the functions.**

An interesting feature of the COMPALARM A, are the interconnections available at its splittable terminal, which makes the wiring much easier, as it allows to wire the terminal block detached from the card.

The particular position of the terminal block allows also to optimize the available space at the board.

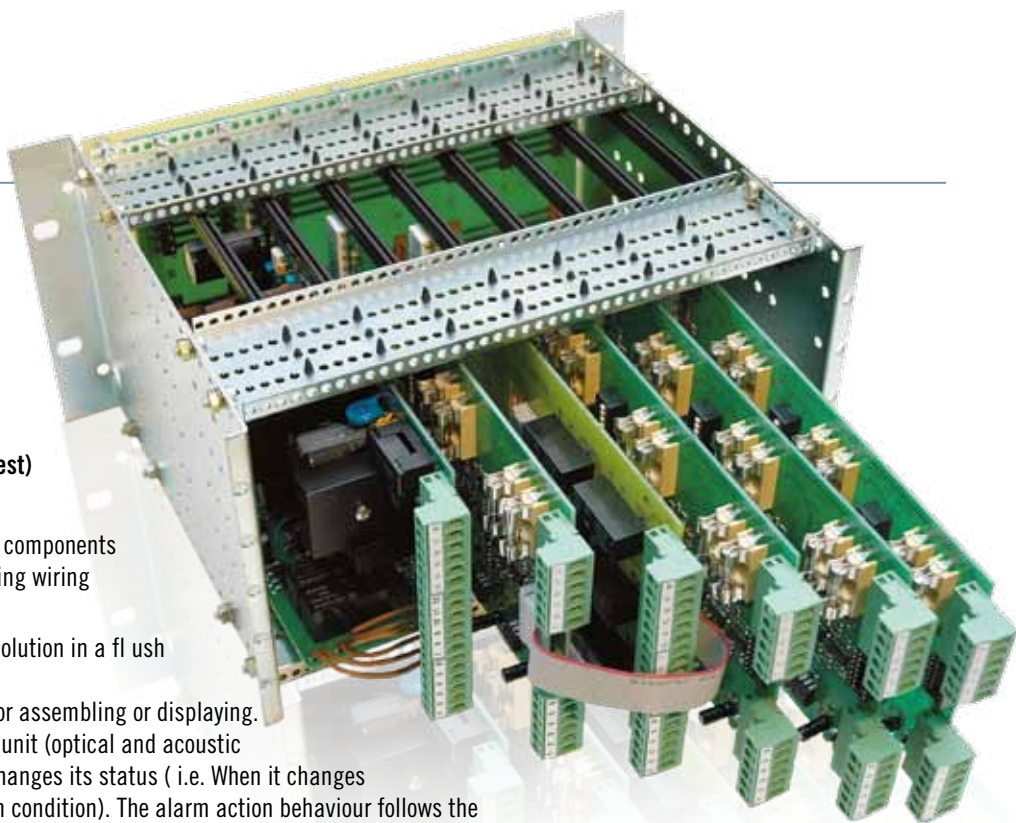

## ELECTRICAL CHARACTERISTICS

Auxiliary power supply	24-48-110-220-380
Operating contact voltage	18 ÷ 38 V
Current input	4mA Aproximately
Electronic circuits consumption	Negligible compared to that of the lamps
Optical signalling output	250 mA max
1 change-over contact for acoustic signalling	10 A - 250 Va.c. Resistive load
Output relay for remote control 1 change-over	10 A - 250 Va.c. Resistive load
Remote repeating output relay (for all points) 1 change-over load	10 A - 250 Va.c. Resistive
Static output for remote control of the relay	24 Vc.c - 250 mA max
Flashing frequency	1F Slow frequency 2F Fast frequency
	1÷1,5 Hz 2÷3 Hz
Power of transformers a.c./a.c.	30-50-100-200 VA
Power of converters d.c./d.c.	50-100-250 W
Working temperature	-10°C ÷ 60°C
Storing temperature	-20°C ÷ +80°C
Relative Humidity	90%
Isolation test	2kV 60 seg

TABLE OF SEQUENCES

Sequence specifications		Type of signal	Normal conditions	Alarm condition	After acknowledge		Return to normal conditions	After reset	Push buttons required
ISA-RP181	ISA-S18.1				Persisting Alarm	Momentary Alarm			
ISA1	A	Optical	Off	Flashing	On	Off	Off	-	Acknowledge
		Acoustic	Silent	Blows	Silent	Silent	Silent	-	
ISA1A	A-5	Optical	Off	On	On	Off	Off	-	Acknowledge
		Acoustic	Silent	Blows	Silent	Tace	Silent	-	
ISA1B	A-4	Optical	Off	Blows*	On	-	Off	-	Acknowledge
		Acoustic	Silent	Blows*	Silent	-	Silent	-	
ISA1C	A-4-5	Optical	Off	On*	On	-	Off	-	Acknowledge
		Acoustic	Silent	Blows*	Silent	-	Silent	-	
ISA2A	R-8	Optical	Off	Flashing fast	On	Flashing slow	Flashing slow	Off	Acknowledge and reset
		Acoustic	Silent	Blows*	Silent	Blows	Blows	Silent	
ISA2C	M	Optical	Off	Blows	On	On	On	Off	Acknowledge and reset
		Acoustic	Silent	Blows	Silent	Tace	Silent	Silent	
ISA2D	M-5	Optical	Off	On	On	On	On	Off	Acknowledge and reset
		Acoustic	Silent	Blows	Silent	Silent	Silent	Silent	
SPECIAL CL 101**		Optical	A) On B) Off	Blows	Blows	A) On B) Off	A) On B) Off	-	Acknowledge
		Acoustic	Silent	Blows	Silent	Silent	Silent	-	

\* Valid condition during the pulse duration only, this is to say, the momentary alarms come back to normal condition without pressing on the acknowledge push-button.

\*\* The present sequence is particularly suitable for the motor operation control.

The (A) shows that motor is running

The (B) shows that motor is stopped

WIRING DIAGRAM

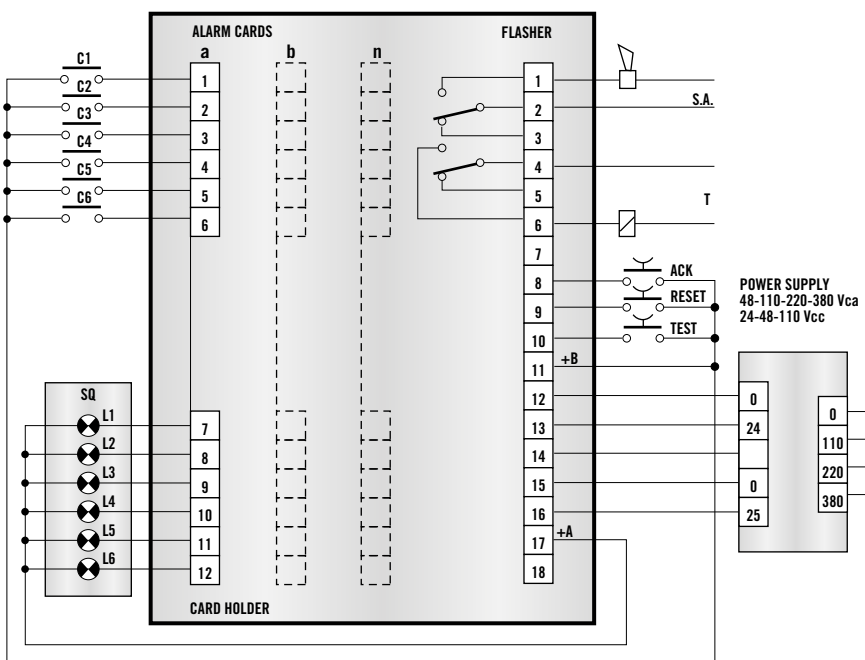

a/b/---/n/	Alarm cards (in each card of 6 points the terminals 1÷6 are corresponding to the alarm inputs, whilst the terminals 7÷12 correspond to the lamps output)
Flascher	Power supply and flashing card.
S.A.	Acoustic signaling relay.
T	Remote control relay for remote cumulative detection of the system in alarm condition.
ACK	Acknowledgement push button.
RESET	Reset push button.
P.A.	Test of sequence push button
+A	Common for lamps.
+B	Common for contacts and push buttons.
Note:	The common for lamps (+A) and the common for contacts and push buttons (+B) should be well identified, in order to have a complete separation of the alarm electronic systems and the external circuits (input/output contacts, lamps -external push buttons, supply).

**DESCRIPTION**

**ALARM CARD**

With 100x190-mm size, it is capable of governing up to 6 alarm points (4-alarm point card is also available). This card is subdivided in 6 or 4 different sections, in order to allow them a totally independent operation, to prevent that good working of more than one alarm point can be affected by failure of one single component.

This card is capable of accepting either normally open input contacts (NO) or normally closed contacts (NC). Selection is made by means of dip-switches, placed on the card and can be varied at any instant without involving the electronics circuitry.

The selection of the input contact is independent for each point and therefore, the card operation is being possible partly with some normally open contacts (NO) and other normally closed contacts (NC).

In a few applications it can be of use to discriminate which of a certain group of alarms has tripped first. To check this, it is necessary to resort to a different behavior between the first tripped alarm and the subsequent alarms, by using the first out. Successive alarms show to be in already acknowledged, in this case.

The lamp does not flash and siren remains still when tripping of successive alarm, this until the first tripped alarm has been acknowledged. The first out is applicable to the sequences ISA 1 - ISA2C - ISA2A (A-M-R8), whilst it is of no use if applied to sequences ISA1 A, ISA1 B, ISA1C - ISA1 D (A5-A4-A45 -M5).

The ISA1 is the most used sequence with first out and it is identified with the reference ISA4A (F 1A). When the card is arranged to operate with first-out sequence, adequate dipswitches are fitted to it. It allows the eventual exclusion of the function for each alarm, thus ensuring the possibility of miscellaneous rating on same card and in the meantime allowing variations in the rating logic during normal use without variations on the electronic circuitry.

The operated alarm sequences are all those as per ISAS18.1 specifications, the most common of which are those indicated in the table at page 4.

**POWER SUPPLY AND FLASHING CARD**

With 100 x 190 mm overall size, it can produce 2 flashing types, 1÷1,5Hz and 2÷3Hz frequency.

On the flash card is located also the relay for the acoustic signaling, the capacity of which is featured by 10 A 250 Vac and 2500 VA as max commutable power.

There is also possibility of inserting in same card the remote control cumulative relay for distance detection of a tripped system, having the same characteristics as for the acoustic signaling relay.

The auxiliary power supply is also signaled by means of green LED on the flashing card. Whilst the simple and double flashing are visualized by two red LEDs, which show the alarm condition.

**RELAY CARD**

With 100x190-mm size, it is capable of housing C6 relays with the following electric characteristics of capacity: 10A, 250Vac and 2500VA, as commuting power.

Said card is used when it is necessary to remotely detect the signals of all single alarm points.

There are 2 different versions available:

- The first one with repeating relays of the alarm condition input contact, i.e. they are deenergized when the alarm signal appears, independently from effected operations.
- The second version with relays, according with the alarm sequence, but only if acknowledgement operations procedures and reset are ended, according with the selected alarm sequence. The wiring with the alarm card, is achieved by using the appropriate flash at connection. The relay card should be inserted close to the alarm card.

**CARDHOLDER**

They are available for 4-7-11-15 card locations, in basic versions. They have the same dimensions as those given in table here below.

These locations can be combined so as to reach the desired number of card locations (by using the interconnection card).

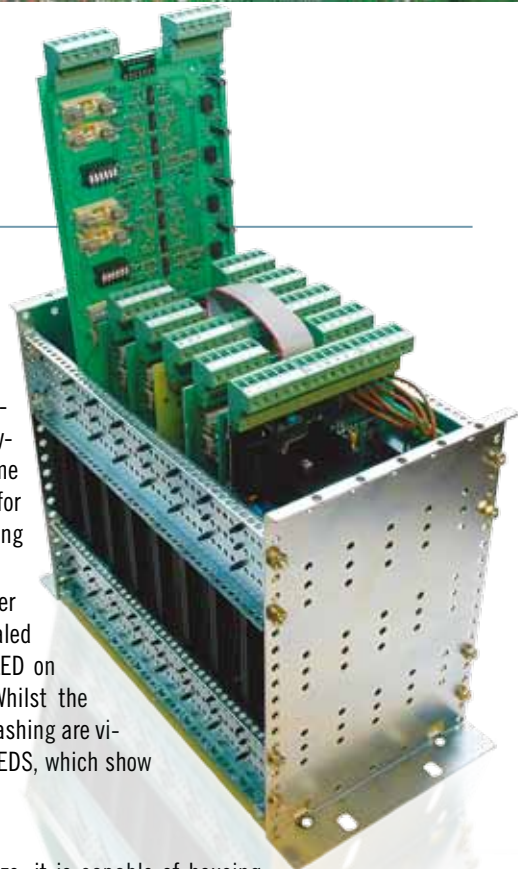

**DIMENSIONS**

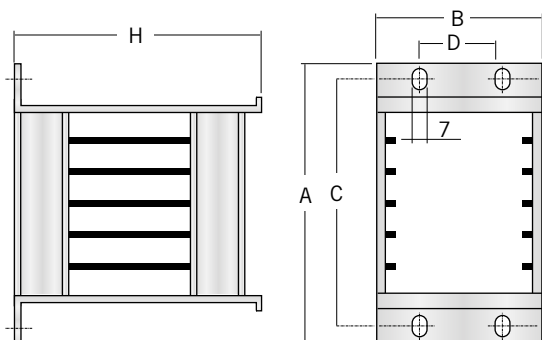

Tipo	A	B	C	D	H
CH4/CH5	200	132,5	183	57	200
CH7/CH8	270	132,5	253	57	200
CH11/CH12	375	132,5	360	57	200
CH15/CH16	484	132,5	467	57	200

## TRANSFORMERS AND CONVERTERS - DIMENSIONS

When the auxiliary voltage available is different from 24 Vac / dc converters or transformers are used with different power. These are also available on the card (ending with the final "F")

TRANSFORMERS						
Type	Power	A	B	C	D	H
TR5	50 VA	80	85	70	60	95
TR10	100 VA	85	85	75	60	95
TR15	150 VA	86	110	75	78	115
TR20	200 VA	86	110	75	78	115
TR25	250 VA	86	110	75	78	115
TR30	300 VA	100	120	90	80	125

CONVERTERS						
Type	Power	A	B	C	D	H
DC3	30 W	200	132,5	183	57	200
DC3F	30 W	EXECUTION ON CARD				
DC10	100 W	200	132,5	183	57	200
DC10F	100 W	EXECUTION ON CARD				
DC25	250 W	200	132,5	183	57	200

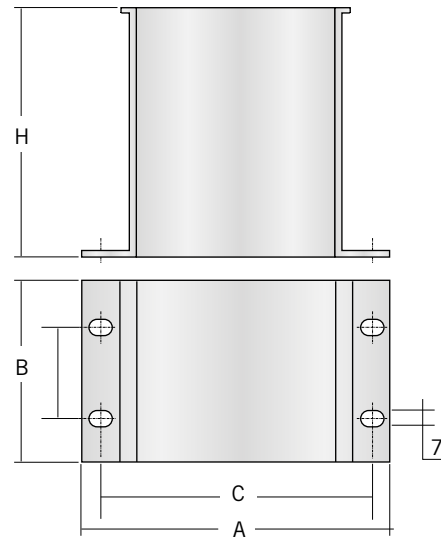
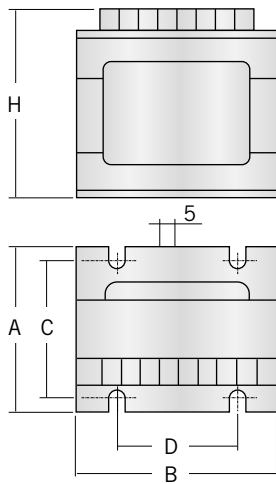

## VERSIONS PRE-WIRED RACK - DIMENSIONS

Type	Number of points	A	B	C	D	E	H
Ep12	12	200	150	170	183	135	300
Ep18	18	270	150	240	253	135	300
Ep24	24	270	180	240	253	165	300
Ep30	30	375	150	347	360	135	300
Ep39	39	484	150	454	467	135	300
Ep48	48	484	180	454	467	165	300
Ep60	60	484	210	454	467	165	300

