



Fluted grip, three-arm,
wing knobs with
torque limiting

STANDARD MACHINE ELEMENTS WORLDWIDE

elesa®

Fluted grip, three-arm, wing knobs with torque limiting

Elesa torque limiting products allow for the regulation of the maximum tightening torque most suitable for your needs. They may be used in various sectors where a sufficiently high tightening torque is required in order to obtain fast and secure fastening, such as laboratory equipment, key duplicators, tool sharpening and sports equipment.

A wide range of applicable torques

Elesa torque limiting clamping elements cover a wide range of applicable torques, from 0.2Nm to 6Nm.

Different shapes available for one optimal grip

Elesa products have the most suitable shape to apply the required tightening torque, adapting to the operator's grip in order to facilitate tightening operation.

Torque visibility

The maximum applicable torque is shown on each product (engraved on the cap or lasered on the product).

Easy adjustment

The torque setting on the MZD knob is easy and intuitive and allows a quick variation of the maximum applicable torque between 0.2Nm and 1Nm.

Resistance

The product tests show that the torque limiting mechanism is fully operational after thousands of cycles.

Application examples





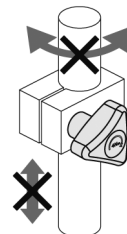

To prevent sheet deformation



Fastening of the tube to avoid damage to tube surfaces



		Torque (Nm)											
		0,2	0,7	1	1,5	2	2,2	2,5	3	3,2	4	5,5	6
	MZD Adjustable fluted grip knob for clamping at low torques.	↔ Adjustable ↔											
	CTD Wing knob for clamping at medium torques.					■			■				
	VTD Three-arm knob for clamping at high torques.					■			■		■		■
	GN 3663 Fluted grip knob for clamping on a wide range of torques.	■	■	■	■	■	■	■	■	■	■	■	■

MATERIAL

Glass-fibre reinforced polyamide based (PA) technopolymer, black colour, matte finish.

CLOSING CAP

Polyamide-based (PA) technopolymer, RAL 7035 grey colour, push-fit assembly.

STANDARD EXECUTIONS

- **MZD-A**: black-oxide steel boss, threaded blind hole.
- **MZD-p**: black-oxide steel threaded screw, chamfered flat end UNI 947 : ISO 4753 (see Catalogue 166 Technical data on page A-11).

FEATURES AND APPLICATIONS

The knob MZD incorporates a mechanism (ELESA patent) which, screwing clockwise until locking, reaches the required torque value by releasing it from the clamping element (boss or threaded screw).

The knob is used when the applied tightening torque must not exceed a certain value.

The torque transmission from the knob to the clamping element occurs by means of a spring system that prevents the set torque from being exceeded. By rotating counterclockwise, the knob unlocks.

The knob has been tested up to 60000 tightening cycles and the values of the torque were unchanged.

SPECIAL EXECUTIONS ON REQUEST

Clamping element with threads and different lengths of stud.



ELESA Original design

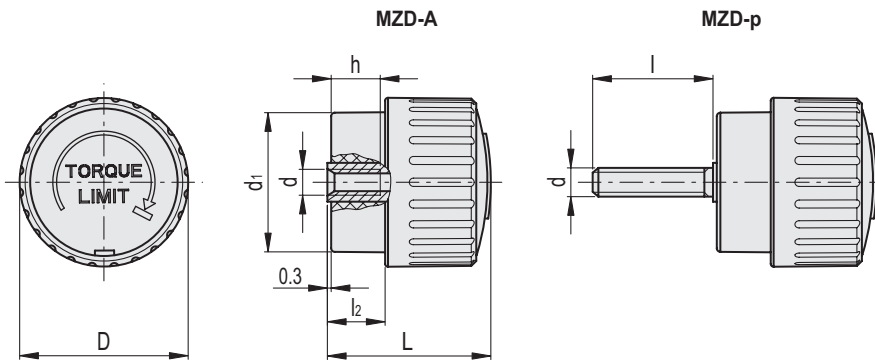

MZD-A

Code	Description	D	d6H	L	d1	l2	h	⚖️
35501	MZD.50-A-M6	47	M6	44	39	15	12	75
35502	MZD.50-A-M8	47	M8	44	39	15	12	74

MZD-p

Code	Description	D	d6g	L	d1	l	l2	⚖️
35511	MZD.50-p-M6x30	47	M6	44	39	30	15	82
35521	MZD.50-p-M8x40	47	M8	44	39	40	15	86

TORQUE ADJUSTMENT

1. Remove the cap by inserting a screwdriver in the special slot.
2. The factory setting of the knob is 0.5 Nm. To increase or decrease the torque value, axially change the position of the disc with graduations by moving the center screw by means of a hexagonal key (ch = 2.5).

The nominal value of the torque can be read on the small inclined plane at the disc level in correspondence with the reference mark, and it is adjustable between 0.2 and 1 Nm.

The accuracy of the nominal value of the torque depends on the accuracy with which the adjustment is carried out by the operator (see table).

The repeatability of the torque remains within limits of $\pm 10\%$.

3. Re-fit the cap by inserting it into its seat with a slight pressure.

Graduations engraved on inclined planes	
Torque Nm	
Fig.1	0.2 – 0.4
Fig.2	0.5 – 0.7
Fig.3	0.8 – 1.0

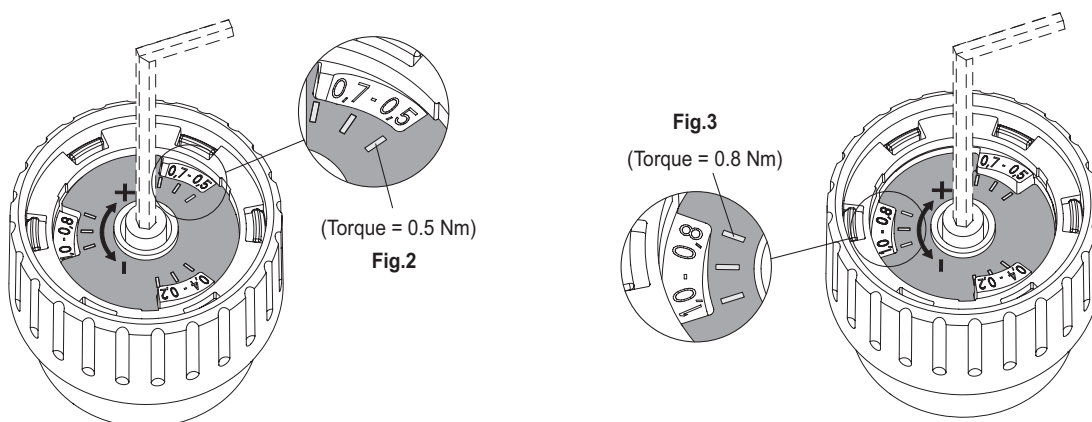
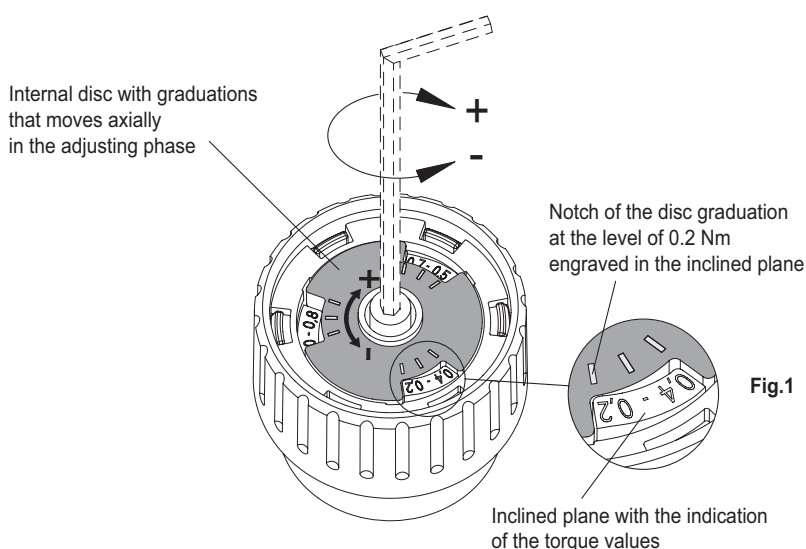

KNOB BODY

Glass-fibre reinforced polyamide based (PA) technopolymer, black colour, matte finish.

CENTRE CAP

Polyamide-based (PA) technopolymer, RAL 7035 grey colour, matte finish.

TORQUE LIMITING MECHANISM

Hardened steel.

STANDARD EXECUTIONS

Zinc-plated steel boss with threaded blind hole.

- **VTD-AZ-2:** maximum torque 2Nm.
- **VTD-AZ-3:** maximum torque 3Nm.
- **VTD-AZ-4:** maximum torque 4Nm.
- **VTD-AZ-6:** maximum torque 6Nm.

FEATURES AND APPLICATIONS

VTD knob is used when the applied tightening torque must not exceed a certain value.

The transmission of the torque from the knob to the clamping element takes place by means of a spring system which, upon reaching the required torque, releases the knob. When the established torque is exceeded, a "click" will be heard to indicate that maximum tightening has been achieved.

By turning the knob anticlockwise the mechanism (Elesa patent) unlocks.

The knob has been tested up to 60000 tightening cycles and the values of the torque were unchanged.

SPECIAL EXECUTIONS ON REQUEST

- Knobs with threaded screw.
- Knobs with different values of max. torque.
- Knobs with stainless steel metal parts and NBR synthetic rubber O-Ring.
- Knobs with cap supplied in other colours.

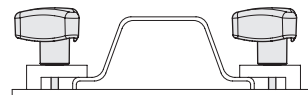

ELESA Original design

Application example

To prevent sheet deformation

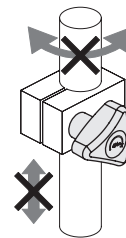

Fastening of the tube to avoid damage to tube surfaces

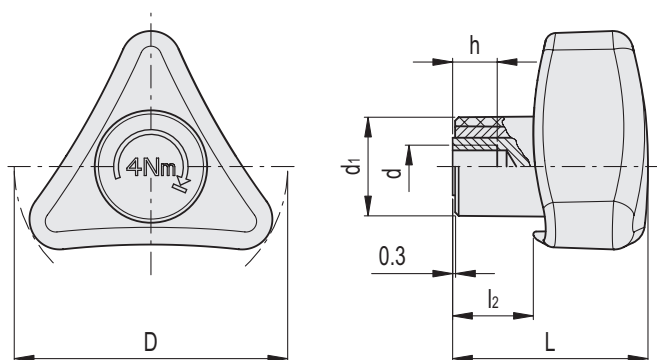

Code	Description	D	d	L	d1	l2	h	C# [Nm]	
35601-2N	VTD.60-AZ-M6-2Nm	60	M6	50.5	27.5	20	10	2	94
35601-3N	VTD.60-AZ-M6-3Nm	60	M6	50.5	27.5	20	10	3	94
35602-2N	VTD.60-AZ-M8-2Nm	60	M8	50.5	27.5	20	12	2	92
35602-3N	VTD.60-AZ-M8-3Nm	60	M8	50.5	27.5	20	12	3	92
35611-4N	VTD.80-AZ-M8-4Nm	80	M8	53.5	27.5	22	12	4	94
35611-6N	VTD.80-AZ-M8-6Nm	80	M8	53.5	27.5	22	12	6	94
35612-4N	VTD.80-AZ-M10-4Nm	80	M10	53.5	27.5	22	12	4	92
35612-6N	VTD.80-AZ-M10-6Nm	80	M10	53.5	27.5	22	12	6	92
35613-4N	VTD.80-AZ-M12-4Nm	80	M12	53.5	27.5	22	12	4	90
35613-6N	VTD.80-AZ-M12-6Nm	80	M12	53.5	27.5	22	12	6	90

Maximum torque

KNOB BODY

Anodised aluminium black colour.

CENTRE CLOSING CAP

Acetal resin based (POM) technopolymer, light-grey colour.

TORQUE LIMITING MECHANISM

Black-oxide steel.

STANDARD EXECUTIONS

Black-oxide steel clamping element, screw, spring and thrust washer.

- GN 3663 (d2): threaded hole.
- GN 3663 (d4 - I): threaded screw.

FEATURES AND APPLICATIONS

GN 3663 knobs are used when the applied tightening torque (see C# ±10% in the Table) must not exceed a certain value. The torque transmission from the knob to the clamping element takes place by means of a spring system which prevents the overcoming of the established torque. Upon exceeding the established torque, a "click" sound will be heard to indicate that the maximum tightening has been reached. By turning the knob anticlockwise the mechanism unlocks.

SPECIAL EXECUTIONS ON REQUEST

- Executions with clamping element with plain hole.
- Executions with clamping element with different threadings and lengths.
- Different values of torque limiting.
- Torque limiting knobs for anticlockwise clamping.



GN 3663 (d2)

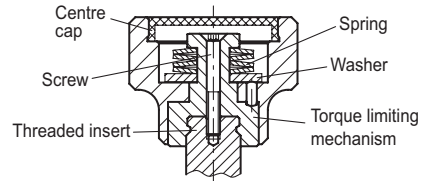
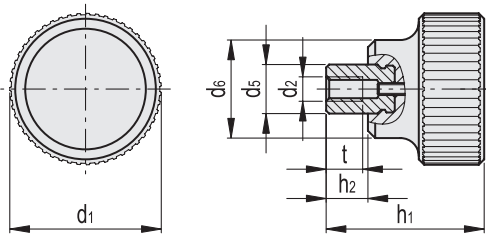

GN 3663 (d2)

Code	Description	d1	d2	d5	d6	h1	h2	t _{min}	C# [Nm]
GN.41401	GN 3663-27-M3-0.7	27	M3	10	19	35	9.5	7	0.7
GN.41402	GN 3663-27-M3-1	27	M3	10	19	35	9.5	7	1.0
GN.41403	GN 3663-27-M3-1.5	27	M3	10	19	35	9.5	7	1.5
GN.41406	GN 3663-27-M4-0.7	27	M4	10	19	35	9.5	9	0.7
GN.41407	GN 3663-27-M4-1	27	M4	10	19	35	9.5	9	1.0
GN.41408	GN 3663-27-M4-1.5	27	M4	10	19	35	9.5	9	1.5
GN.41411	GN 3663-27-M5-0.7	27	M5	10	19	35	9.5	9	0.7
GN.41412	GN 3663-27-M5-1	27	M5	10	19	35	9.5	9	1.0
GN.41413	GN 3663-27-M5-1.5	27	M5	10	19	35	9.5	9	1.5
GN.41416	GN 3663-27-M6-0.7	27	M6	10	19	35	9.5	9	0.7
GN.41417	GN 3663-27-M6-1	27	M6	10	19	35	9.5	9	1.0
GN.41418	GN 3663-27-M6-1.5	27	M6	10	19	35	9.5	9	1.5
GN.41471	GN 3663-34-M3-1	34	M3	10	21	37.5	9.5	7	1.0
GN.41472	GN 3663-34-M3-1.5	34	M3	10	21	37.5	9.5	7	1.5
GN.41473	GN 3663-34-M3-2.2	34	M3	10	21	37.5	9.5	7	2.2
GN.41476	GN 3663-34-M4-1	34	M4	10	21	37.5	9.5	9	1.0
GN.41477	GN 3663-34-M4-1.5	34	M4	10	21	37.5	9.5	9	1.5
GN.41478	GN 3663-34-M4-2.2	34	M4	10	21	37.5	9.5	9	2.2
GN.41481	GN 3663-34-M5-1	34	M5	10	21	37.5	9.5	9	1.0
GN.41482	GN 3663-34-M5-1.5	34	M5	10	21	37.5	9.5	9	1.5
GN.41483	GN 3663-34-M5-2.2	34	M5	10	21	37.5	9.5	9	2.2

GN 3663 (d2)

Code	Description	d1	d2	d5	d6	h1	h2	t _{min}	C# [Nm]
GN.41486	GN 3663-34-M6-1	34	M6	10	21	37.5	9.5	9	1.0
GN.41487	GN 3663-34-M6-1.5	34	M6	10	21	37.5	9.5	9	1.5
GN.41488	GN 3663-34-M6-2.2	34	M6	10	21	37.5	9.5	9	2.2
GN.41551	GN 3663-42-M6-2	42	M6	13.5	27	43.5	11.5	11	2.0
GN.41552	GN 3663-42-M6-2.5	42	M6	13.5	27	43.5	11.5	11	2.5
GN.41553	GN 3663-42-M6-3.2	42	M6	13.5	27	43.5	11.5	11	3.2
GN.41556	GN 3663-42-M8-2	42	M8	13.5	27	43.5	11.5	11	2.0
GN.41557	GN 3663-42-M8-2.5	42	M8	13.5	27	43.5	11.5	11	2.5
GN.41558	GN 3663-42-M8-3.2	42	M8	13.5	27	43.5	11.5	11	3.2
GN.41621	GN 3663-52-M10-2.5	52	M10	19	32	54	15.5	17	2.5
GN.41622	GN 3663-52-M10-3	52	M10	19	32	54	15.5	17	3.0
GN.41623	GN 3663-52-M10-4	52	M10	19	32	54	15.5	17	4.0
GN.41626	GN 3663-52-M12-2.5	52	M12	19	32	54	15.5	17	2.5
GN.41627	GN 3663-52-M12-3	52	M12	19	32	54	15.5	17	3.0
GN.41628	GN 3663-52-M12-4	52	M12	19	32	54	15.5	17	4.0
GN.41701	GN 3663-62-M10-3	62	M10	19	33	54	15.5	17	3.0
GN.41702	GN 3663-62-M10-4	62	M10	19	33	54	15.5	17	4.0
GN.41703	GN 3663-62-M10-5.5	62	M10	19	33	54	15.5	17	5.5
GN.41706	GN 3663-62-M12-3	62	M12	19	33	54	15.5	17	3.0
GN.41707	GN 3663-62-M12-4	62	M12	19	33	54	15.5	17	4.0
GN.41708	GN 3663-62-M12-5.5	62	M12	19	33	54	15.5	17	5.5

GN 3663 (d4 - I)

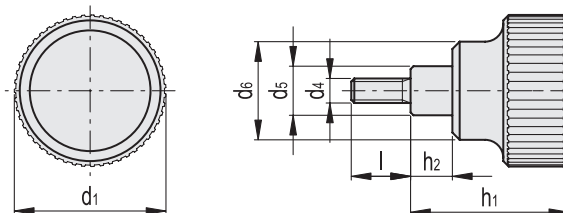

GN 3663 (d4 - I)

Code	Description	d1	d4	d5	d6	h1	h2	l	C# [Nm]
GN.41421	GN 3663-27-M4-12-0.7	27	M4	10	19	35	9.5	12	0.7
GN.41422	GN 3663-27-M4-12-1	27	M4	10	19	35	9.5	12	1.0
GN.41423	GN 3663-27-M4-12-1.5	27	M4	10	19	35	9.5	12	1.5
GN.41426	GN 3663-27-M4-16-0.7	27	M4	10	19	35	9.5	16	0.7
GN.41427	GN 3663-27-M4-16-1	27	M4	10	19	35	9.5	16	1.0
GN.41428	GN 3663-27-M4-16-1.5	27	M4	10	19	35	9.5	16	1.5
GN.41431	GN 3663-27-M4-20-0.7	27	M4	10	19	35	9.5	20	0.7
GN.41432	GN 3663-27-M4-20-1	27	M4	10	19	35	9.5	20	1.0
GN.41433	GN 3663-27-M4-20-1.5	27	M4	10	19	35	9.5	20	1.5
GN.41436	GN 3663-27-M4-25-0.7	27	M4	10	19	35	9.5	25	0.7
GN.41437	GN 3663-27-M4-25-1	27	M4	10	19	35	9.5	25	1.0
GN.41438	GN 3663-27-M4-25-1.5	27	M4	10	19	35	9.5	25	1.5
GN.41441	GN 3663-27-M4-32-0.7	27	M4	10	19	35	9.5	32	0.7
GN.41442	GN 3663-27-M4-32-1	27	M4	10	19	35	9.5	32	1.0
GN.41443	GN 3663-27-M4-32-1.5	27	M4	10	19	35	9.5	32	1.5
GN.41446	GN 3663-27-M5-12-0.7	27	M5	10	19	35	9.5	12	0.7
GN.41447	GN 3663-27-M5-12-1	27	M5	10	19	35	9.5	12	1.0
GN.41448	GN 3663-27-M5-12-1.5	27	M5	10	19	35	9.5	12	1.5
GN.41451	GN 3663-27-M5-16-0.7	27	M5	10	19	35	9.5	16	0.7
GN.41452	GN 3663-27-M5-16-1	27	M5	10	19	35	9.5	16	1.0
GN.41453	GN 3663-27-M5-16-1.5	27	M5	10	19	35	9.5	16	1.5
GN.41456	GN 3663-27-M5-20-0.7	27	M5	10	19	35	9.5	20	0.7
GN.41457	GN 3663-27-M5-20-1	27	M5	10	19	35	9.5	20	1.0
GN.41458	GN 3663-27-M5-20-1.5	27	M5	10	19	35	9.5	20	1.5
GN.41461	GN 3663-27-M5-25-0.7	27	M5	10	19	35	9.5	25	0.7
GN.41462	GN 3663-27-M5-25-1	27	M5	10	19	35	9.5	25	1.0
GN.41463	GN 3663-27-M5-25-1.5	27	M5	10	19	35	9.5	25	1.5
GN.41466	GN 3663-27-M5-32-0.7	27	M5	10	19	35	9.5	32	0.7
GN.41467	GN 3663-27-M5-32-1	27	M5	10	19	35	9.5	32	1.0
GN.41468	GN 3663-27-M5-32-1.5	27	M5	10	19	35	9.5	32	1.5
GN.41491	GN 3663-34-M5-12-1	34	M5	10	21	37.5	9.5	12	1.0
GN.41492	GN 3663-34-M5-12-1.5	34	M5	10	21	37.5	9.5	12	1.5
GN.41493	GN 3663-34-M5-12-2.2	34	M5	10	21	37.5	9.5	12	2.2
GN.41496	GN 3663-34-M5-16-1	34	M5	10	21	37.5	9.5	16	1.0
GN.41497	GN 3663-34-M5-16-1.5	34	M5	10	21	37.5	9.5	16	1.5
GN.41498	GN 3663-34-M5-16-2.2	34	M5	10	21	37.5	9.5	16	2.2
GN.41501	GN 3663-34-M5-20-1	34	M5	10	21	37.5	9.5	20	1.0
GN.41502	GN 3663-34-M5-20-1.5	34	M5	10	21	37.5	9.5	20	1.5

Tightening torque $\pm 10\%$

GN 3663 (d4 - I)

Code	Description	d1	d4	d5	d6	h1	h2	l	C# [Nm]
GN.41503	GN 3663-34-M5-20-2.2	34	M5	10	21	37.5	9.5	20	2.2
GN.41506	GN 3663-34-M5-25-1	34	M5	10	21	37.5	9.5	25	1.0
GN.41507	GN 3663-34-M5-25-1.5	34	M5	10	21	37.5	9.5	25	1.5
GN.41508	GN 3663-34-M5-25-2.2	34	M5	10	21	37.5	9.5	25	2.2
GN.41511	GN 3663-34-M5-32-1	34	M5	10	21	37.5	9.5	32	1.0
GN.41512	GN 3663-34-M5-32-1.5	34	M5	10	21	37.5	9.5	32	1.5
GN.41513	GN 3663-34-M5-32-2.2	34	M5	10	21	37.5	9.5	32	2.2
GN.41516	GN 3663-34-M6-12-1	34	M6	10	21	37.5	9.5	12	1.0
GN.41517	GN 3663-34-M6-12-1.5	34	M6	10	21	37.5	9.5	12	1.5
GN.41518	GN 3663-34-M6-12-2.2	34	M6	10	21	37.5	9.5	12	2.2
GN.41521	GN 3663-34-M6-16-1	34	M6	10	21	37.5	9.5	16	1.0
GN.41522	GN 3663-34-M6-16-1.5	34	M6	10	21	37.5	9.5	16	1.5
GN.41523	GN 3663-34-M6-16-2.2	34	M6	10	21	37.5	9.5	16	2.2
GN.41526	GN 3663-34-M6-20-1	34	M6	10	21	37.5	9.5	20	1.0
GN.41527	GN 3663-34-M6-20-1.5	34	M6	10	21	37.5	9.5	20	1.5
GN.41528	GN 3663-34-M6-20-2.2	34	M6	10	21	37.5	9.5	20	2.2
GN.41531	GN 3663-34-M6-25-1	34	M6	10	21	37.5	9.5	25	1.0
GN.41532	GN 3663-34-M6-25-1.5	34	M6	10	21	37.5	9.5	25	1.5
GN.41533	GN 3663-34-M6-25-2.2	34	M6	10	21	37.5	9.5	25	2.2
GN.41536	GN 3663-34-M6-32-1	34	M6	10	21	37.5	9.5	32	1.0
GN.41537	GN 3663-34-M6-32-1.5	34	M6	10	21	37.5	9.5	32	1.5
GN.41538	GN 3663-34-M6-32-2.2	34	M6	10	21	37.5	9.5	32	2.2
GN.41561	GN 3663-42-M8-16-2	42	M8	13.5	27	43.5	11.5	16	2.0
GN.41562	GN 3663-42-M8-16-2.5	42	M8	13.5	27	43.5	11.5	16	2.5
GN.41563	GN 3663-42-M8-16-3.2	42	M8	13.5	27	43.5	11.5	16	3.2
GN.41566	GN 3663-42-M8-20-2	42	M8	13.5	27	43.5	11.5	20	2.0
GN.41567	GN 3663-42-M8-20-2.5	42	M8	13.5	27	43.5	11.5	20	2.5
GN.41568	GN 3663-42-M8-20-3.2	42	M8	13.5	27	43.5	11.5	20	3.2
GN.41571	GN 3663-42-M8-25-2	42	M8	13.5	27	43.5	11.5	25	2.0
GN.41572	GN 3663-42-M8-25-2.5	42	M8	13.5	27	43.5	11.5	25	2.5
GN.41573	GN 3663-42-M8-25-3.2	42	M8	13.5	27	43.5	11.5	25	3.2
GN.41576	GN 3663-42-M8-32-2	42	M8	13.5	27	43.5	11.5	32	2.0
GN.41577	GN 3663-42-M8-32-2.5	42	M8	13.5	27	43.5	11.5	32	2.5
GN.41578	GN 3663-42-M8-32-3.2	42	M8	13.5	27	43.5	11.5	32	3.2
GN.41581	GN 3663-42-M8-40-2	42	M8	13.5	27	43.5	11.5	40	2.0
GN.41582	GN 3663-42-M8-40-2.5	42	M8	13.5	27	43.5	11.5	40	2.5
GN.41583	GN 3663-42-M8-40-3.2	42	M8	13.5	27	43.5	11.5	40	3.2
GN.41586	GN 3663-42-M10-20-2	42	M10	13.5	27	43.5	11.5	20	2.0

Tightening torque $\pm 10\%$

GN 3663 (d4 - l)

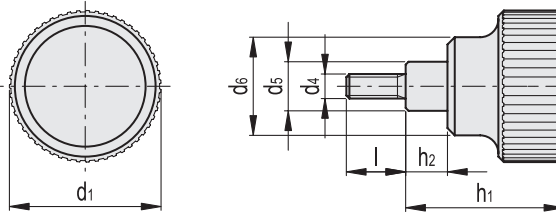

GN 3663 (d4 - l)

Code	Description	d1	d4	d5	d6	h1	h2	l	C# [Nm]
GN.41587	GN 3663-42-M10-20-2.5	42	M10	13.5	27	43.5	11.5	20	2.5
GN.41588	GN 3663-42-M10-20-3.2	42	M10	13.5	27	43.5	11.5	20	3.2
GN.41591	GN 3663-42-M10-25-2	42	M10	13.5	27	43.5	11.5	25	2.0
GN.41592	GN 3663-42-M10-25-2.5	42	M10	13.5	27	43.5	11.5	25	2.5
GN.41593	GN 3663-42-M10-25-3.2	42	M10	13.5	27	43.5	11.5	25	3.2
GN.41596	GN 3663-42-M10-32-2	42	M10	13.5	27	43.5	11.5	32	2.0
GN.41597	GN 3663-42-M10-32-2.5	42	M10	13.5	27	43.5	11.5	32	2.5
GN.41598	GN 3663-42-M10-32-3.2	42	M10	13.5	27	43.5	11.5	32	3.2
GN.41601	GN 3663-42-M10-40-2	42	M10	13.5	27	43.5	11.5	40	2.0
GN.41602	GN 3663-42-M10-40-2.5	42	M10	13.5	27	43.5	11.5	40	2.5
GN.41603	GN 3663-42-M10-40-3.2	42	M10	13.5	27	43.5	11.5	40	3.2
GN.41606	GN 3663-42-M10-50-2	42	M10	13.5	27	43.5	11.5	50	2.0
GN.41607	GN 3663-42-M10-50-2.5	42	M10	13.5	27	43.5	11.5	50	2.5
GN.41608	GN 3663-42-M10-50-3.2	42	M10	13.5	27	43.5	11.5	50	3.2
GN.41631	GN 3663-52-M10-25-2.5	52	M10	19	32	54	15.5	25	2.5
GN.41632	GN 3663-52-M10-25-3	52	M10	19	32	54	15.5	25	3.0
GN.41633	GN 3663-52-M10-25-4	52	M10	19	32	54	15.5	25	4.0
GN.41636	GN 3663-52-M10-32-2.5	52	M10	19	32	54	15.5	32	2.5
GN.41637	GN 3663-52-M10-32-3	52	M10	19	32	54	15.5	32	3.0
GN.41638	GN 3663-52-M10-32-4	52	M10	19	32	54	15.5	32	4.0
GN.41641	GN 3663-52-M10-40-2.5	52	M10	19	32	54	15.5	40	2.5
GN.41642	GN 3663-52-M10-40-3	52	M10	19	32	54	15.5	40	3.0
GN.41643	GN 3663-52-M10-40-4	52	M10	19	32	54	15.5	40	4.0
GN.41646	GN 3663-52-M10-50-2.5	52	M10	19	32	54	15.5	50	2.5
GN.41647	GN 3663-52-M10-50-3	52	M10	19	32	54	15.5	50	3.0
GN.41648	GN 3663-52-M10-50-4	52	M10	19	32	54	15.5	50	4.0
GN.41651	GN 3663-52-M10-63-2.5	52	M10	19	32	54	15.5	63	2.5
GN.41652	GN 3663-52-M10-63-3	52	M10	19	32	54	15.5	63	3.0
GN.41653	GN 3663-52-M10-63-4	52	M10	19	32	54	15.5	63	4.0
GN.41656	GN 3663-52-M12-25-2.5	52	M12	19	32	54	15.5	25	2.5
GN.41657	GN 3663-52-M12-25-3	52	M12	19	32	54	15.5	25	3.0
GN.41658	GN 3663-52-M12-25-4	52	M12	19	32	54	15.5	25	4.0
GN.41661	GN 3663-52-M12-32-2.5	52	M12	19	32	54	15.5	32	2.5
GN.41662	GN 3663-52-M12-32-3	52	M12	19	32	54	15.5	32	3.0
GN.41663	GN 3663-52-M12-32-4	52	M12	19	32	54	15.5	32	4.0
GN.41666	GN 3663-52-M12-40-2.5	52	M12	19	32	54	15.5	40	2.5
GN.41667	GN 3663-52-M12-40-3	52	M12	19	32	54	15.5	40	3.0
GN.41668	GN 3663-52-M12-40-4	52	M12	19	32	54	15.5	40	4.0

GN 3663 (d4 - l)

Code	Description	d1	d4	d5	d6	h1	h2	l	C# [Nm]
GN.41671	GN 3663-52-M12-50-2.5	52	M12	19	32	54	15.5	50	2.5
GN.41672	GN 3663-52-M12-50-3	52	M12	19	32	54	15.5	50	3.0
GN.41673	GN 3663-52-M12-50-4	52	M12	19	32	54	15.5	50	4.0
GN.41676	GN 3663-52-M12-63-2.5	52	M12	19	32	54	15.5	63	2.5
GN.41677	GN 3663-52-M12-63-3	52	M12	19	32	54	15.5	63	3.0
GN.41678	GN 3663-52-M12-63-4	52	M12	19	32	54	15.5	63	4.0
GN.41711	GN 3663-62-M10-25-3	62	M10	19	33	54	15.5	25	3.0
GN.41712	GN 3663-62-M10-25-4	62	M10	19	33	54	15.5	25	4.0
GN.41713	GN 3663-62-M10-25-5.5	62	M10	19	33	54	15.5	25	5.5
GN.41716	GN 3663-62-M10-32-3	62	M10	19	33	54	15.5	32	3.0
GN.41717	GN 3663-62-M10-32-4	62	M10	19	33	54	15.5	32	4.0
GN.41718	GN 3663-62-M10-32-5.5	62	M10	19	33	54	15.5	32	5.5
GN.41721	GN 3663-62-M10-40-3	62	M10	19	33	54	15.5	40	3.0
GN.41722	GN 3663-62-M10-40-4	62	M10	19	33	54	15.5	40	4.0
GN.41723	GN 3663-62-M10-40-5.5	62	M10	19	33	54	15.5	40	5.5
GN.41726	GN 3663-62-M10-50-3	62	M10	19	33	54	15.5	50	3.0
GN.41727	GN 3663-62-M10-50-4	62	M10	19	33	54	15.5	50	4.0
GN.41728	GN 3663-62-M10-50-5.5	62	M10	19	33	54	15.5	50	5.5
GN.41731	GN 3663-62-M10-63-3	62	M10	19	33	54	15.5	63	3.0
GN.41732	GN 3663-62-M10-63-4	62	M10	19	33	54	15.5	63	4.0
GN.41733	GN 3663-62-M10-63-5.5	62	M10	19	33	54	15.5	63	5.5
GN.41736	GN 3663-62-M12-25-3	62	M12	19	33	54	15.5	25	3.0
GN.41737	GN 3663-62-M12-25-4	62	M12	19	33	54	15.5	25	4.0
GN.41738	GN 3663-62-M12-25-5.5	62	M12	19	33	54	15.5	25	5.5
GN.41741	GN 3663-62-M12-32-3	62	M12	19	33	54	15.5	32	3.0
GN.41742	GN 3663-62-M12-32-4	62	M12	19	33	54	15.5	32	4.0
GN.41743	GN 3663-62-M12-32-5.5	62	M12	19	33	54	15.5	32	5.5
GN.41746	GN 3663-62-M12-40-3	62	M12	19	33	54	15.5	40	3.0
GN.41747	GN 3663-62-M12-40-4	62	M12	19	33	54	15.5	40	4.0
GN.41748	GN 3663-62-M12-40-5.5	62	M12	19	33	54	15.5	40	5.5
GN.41751	GN 3663-62-M12-50-3	62	M12	19	33	54	15.5	50	3.0
GN.41752	GN 3663-62-M12-50-4	62	M12	19	33	54	15.5	50	4.0
GN.41753	GN 3663-62-M12-50-5.5	62	M12	19	33	54	15.5	50	5.5
GN.41756	GN 3663-62-M12-63-3	62	M12	19	33	54	15.5	63	3.0
GN.41757	GN 3663-62-M12-63-4	62	M12	19	33	54	15.5	63	4.0
GN.41758	GN 3663-62-M12-63-5.5	62	M12	19	33	54	15.5	63	5.5

Tightening torque $\pm 10\%$

MATERIAL

Glass-fibre reinforced polyamide based (PA) technopolymer, black (C9) or orange (C2) colour, matte finish.

TORQUE LIMITING MECHANISM

Nickel-plated steel.

STANDARD EXECUTIONS

- **CTD-B-2**: nickel-plated steel boss with threaded blind hole, maximum torque 2Nm.
- **CTD-B-3**: nickel-plated steel boss with threaded blind hole, maximum torque 3Nm.
- **CTD-p-2**: nickel-plated steel threaded screw, maximum torque 2Nm.
- **CTD-p-3**: nickel-plated steel threaded screw, maximum torque 3Nm.

FEATURES AND APPLICATIONS

CTD wing knobs are used when the applied tightening torque must not exceed a preset value.

The torque transmission from the wing knob to the clamping element takes place by means of a spring system which prevents the overcoming of the established torque. Upon exceeding the established torque, a "click" sound will be heard to indicate that the maximum tightening has been reached. By turning the knob anticlockwise the mechanism unlocks.



Application Examples

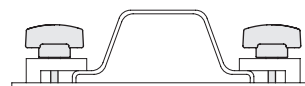

To prevent sheet deformation

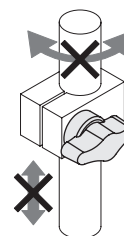

Fastening of the tube to avoid damage to tube surfaces

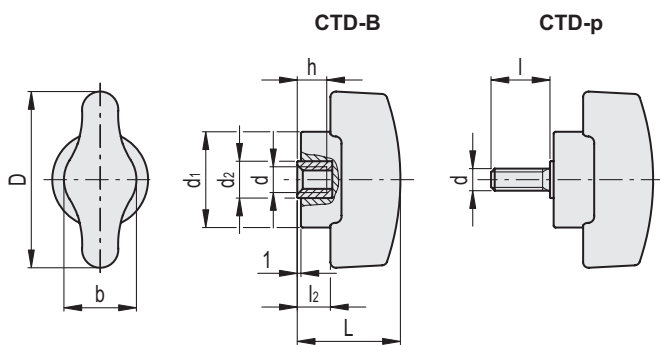

C9 RAL9005 **C2** RAL2004

CTD-B		CTD-B		D	d	L	d1	d2	l2	b	h	C# [Nm]	⚖️
221901-C9	CTD.48 B-M5-2-C9	221901-C2	CTD.48 B-M5-2-C2	48	M5	28	26	10	9	20	8	2	35
221902-C9	CTD.48 B-M5-3-C9	221902-C2	CTD.48 B-M5-3-C2	48	M5	28	26	10	9	20	8	3	36
221905-C9	CTD.48 B-M6-2-C9	221905-C2	CTD.48 B-M6-2-C2	48	M6	28	26	10	9	20	8	2	34
221906-C9	CTD.48 B-M6-3-C9	221906-C2	CTD.48 B-M6-3-C2	48	M6	28	26	10	9	20	8	3	35

CTD-p		CTD-p		D	d	L	d1	d2	l	l2	b	C# [Nm]	⚖️
221951-C9	CTD.48 p-M5x10-2-C9	221951-C2	CTD.48 p-M5x10-2-C2	48	M5	28	26	10	10	9	20	2	37
221952-C9	CTD.48 p-M5x10-3-C9	221952-C2	CTD.48 p-M5x10-3-C2	48	M5	28	26	10	10	9	20	3	38
221955-C9	CTD.48 p-M5x16-2-C9	221955-C2	CTD.48 p-M5x16-2-C2	48	M5	28	26	10	16	9	20	2	38
221956-C9	CTD.48 p-M5x16-3-C9	221956-C2	CTD.48 p-M5x16-3-C2	48	M5	28	26	10	16	9	20	3	39
221961-C9	CTD.48 p-M6x16-2-C9	221961-C2	CTD.48 p-M6x16-2-C2	48	M6	28	26	10	16	9	20	2	39
221962-C9	CTD.48 p-M6x16-3-C9	221962-C2	CTD.48 p-M6x16-3-C2	48	M6	28	26	10	16	9	20	3	40
221965-C9	CTD.48 p-M6x25-2-C9	221965-C2	CTD.48 p-M6x25-2-C2	48	M6	28	26	10	25	9	20	2	41
221966-C9	CTD.48 p-M6x25-3-C9	221966-C2	CTD.48 p-M6x25-3-C2	48	M6	28	26	10	25	9	20	3	42

Maximum torque (±15%)



ELESA. More and more...



Printed in Italy
ZDEPTORQUENG18



elesa®

ELESA S.p.A.
Via Pompei, 29
20900 Monza (MB) Italy
phone +39 039 2811.1
fax +39 039 836351
info@elesa.com

elesa.com

© Copyright ELESA 2018