



IMPORTANT OPERATING DATA AVAILABLE AT A GLANCE

Characteristics	ASV 14	ASV 15	ASV 20	ASV 21	ASV 30	ASV 40
Engine	Volkswagen gas-industrial engine					
	2.0l, 4-cylinder			3.6l, 4-cylinder		
Fuel	natural gas, liquid gas					
Generator	asynchronous, liquid-cooled, high-efficiency (nominal speed 1,500 1/min)					
Gas intake	45 kW (LHV)	48 kW (LHV)	61 kW (LHV)	64 kW (LHV)	100 kW (LHV)	129 kW (LHV)
Electr. power	5 – 14 kW	5 – 15 kW	5 – 20 kW	5 – 21 kW	10 – 30 kW	10 – 40 kW
Therm. power	19 – 32 kW	19 – 34 kW	19 – 44 kW	19 – 46 kW	38 – 73 kW	38 – 85 kW
Electrical / overall efficiency	31 / 102 %		33 / 105 %		30 / 103 %	31 / 97 %
Sound level, in dB (A)	45 – 52		45 – 54		44 – 50	44 – 52
Dimensions	(L x W x H) 1,200 x 800 x 1,520 mm, Footprint only 1 m ²					
Weight	ca. 575 kg			ca. 800 kg		
Temp. return flow	operating temperature up to 65 °C (max. 70 °C)					
Temp. flow line	operating temperature up to 95 °C					

All values are in accordance with DIN 6271 and DIN 6280 at a heating water return temperature of 35 °C and full utilization of the condensing effect, optional equipment features, as well as natural gas and are based on the Lower Heating Value (LHV) = 9.03 kWh/m³, and an intake of 25 °C at a height of 50 m above sea level (1,013 hPa). In other gas quality and other temperatures or heights may vary. The tolerances of the performance specifications are ± 5 %.

As of 03/2017. Specifications and information are subject to change without notice. For errors no liability.

Communication interfaces: The standard remote polling and communications of the CHP on the Internet can be used either via Ethernet (LAN) (standard) or optionally via telecommunication box (GSM modem). Remote updates of CHP software are possible using Ethernet (LAN).

For a complete overview of the technical data visit www.energiewerkstatt.de/en

WHEN PERFORMANCE COUNTS

Energiewerkstatt™ ASV cogeneration units



**Energiewerkstatt Gesellschaft
für rationelle Energie mbH & Co. KG**
Fössestraße 97 A
30453 Hannover
Germany

Phone: +49 511 / 9 49 74 – 0
Telefax: +49 511 / 9 49 74 – 74

info@energiewerkstatt.de
www.energiewerkstatt.de

COGENERATION TECHNOLOGY SINCE 1987

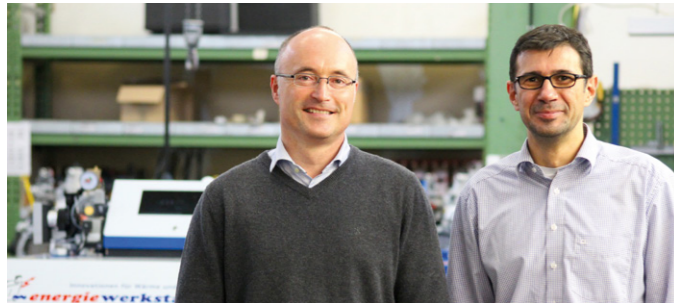

CEOs Lutz Raugust and Lutz Gärtner

With our 30 years of CHP production, consistently advancing and fine tuning efficiency, technologies and reliability of combined heat and power generation units, we are more accessible and recognized in a broadening market with our compact user-friendly and maintenance-friendly CHP units.

In 1987 as a medium sized owner managed company, we became one of the first producers and providers of combined heat and power generator units in Germany. Our products are considered benchmarks. Our engineering team continuously advance our technologies increasing power efficiency and reliability beyond our competitors.

In over 100 sites annually and growing are relied upon every day in municipal facilities, hotels, hospitals, retirement homes etc. generating heat and electricity economically.

Energiewerkstatt™ in 2015 began production of the innovative high-efficiency heat-recovery compressor (HWW) with HERON, the compressed air supplier. Compressed air production costs can be reduced by up to 60 percent using a gas driven compressor in combination with Energiewerkstatt's combined heat and power technologies.

ENERGIEWERKSTATT EXPERTISE FOR YOUR SUCCESS

Energiewerkstatt™ brings together all major tasks of a modern industrial enterprise in one house. This has significant advantages for you as a customer. For example, take advantage of our fast and reliable service, fast decision-making and competent partner for all matters related to your Energiewerkstatt™ CHP.

SERVICE

- Factory service: Fast, reliable and flexible
- Energiewerkstatt™ grants a 10-year availability guarantee and cost control with full maintenance contract
- Retrofit - complete modernization of existing CHP units, including new full maintenance contracts
- Delivery, installation, commissioning, maintenance and repair
- Direct sourcing and availability of original Energiewerkstatt™ spare parts
- Competitive edge through continuous further education and training in innovative patented technology

PRODUCTION

- Made in Germany
- In house factory tests equating to highest quality and reliability for the customer
- Serial production for equal parts concept for high availability and short delivery times
- Constantly optimized production through FMEA process and in-house technological innovation and manufacturing procedures.

DEVELOPMENT

- Decades of experience with cogeneration units and CHP technology.
- Specialized solely in high efficiency equipment
- Industry recognized innovation and customer-oriented
- Continuous improvement of products through permanent access to real-time data for the extensive inventory CHP pools
- Special one to one developments and project realization on request

DISTRIBUTION

- Personal customer service and project management
- Individual calculation of profitability of your CHP project
- Due to the large market nearby fast implementation of customer requirements in a range of products
- We are your contact on all important trade fairs and conferences in Germany
- Professional support and marketing support of sales and service partners

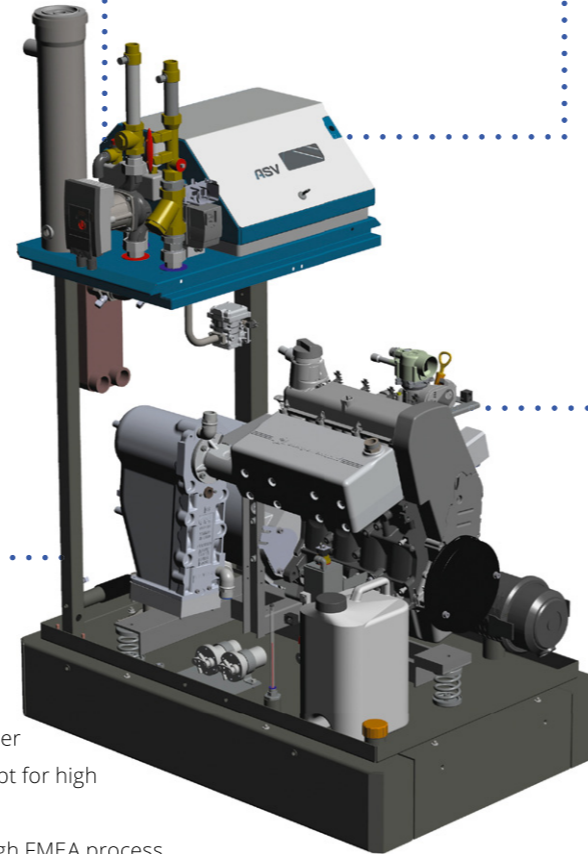

A NEW GENERATION ASV WITH ALL-IN-ONE II

With the constant development of our CHP and accumulated knowledge of almost 1,000 existing installations, we deliver solutions that are optimally tailored to the requirements of customers and installation companies. Our linking of long-term expertise and development and optimization work is unique.

Further increases efficiency, the life improvement and service optimization are core objectives of each integrated unit in the current series. This is especially true of the new All-In-One II control and analysis of optimization in the last three years encourage us to speak of a new generation of ASV-CHP.

YOUR ADVANTAGES

- **Compact:** CHP footprint of 1 m² (80 x 120 cm)
- **High Efficiency:** VdZ (A⁺⁺)
- **Extremely quiet:** 44 – 54 dB(A)
- **Ready:** All components in the integrated CHP
- **Remote internet:** Data encrypted intelligent reporting system
- **Runtime optimization:** By power modulation up to 25 %
- **Process heat utilization:** With flow line temperatures up to 95 °C and option minimum forerun temperature control
- **AIO II controller:** Sophisticated and advanced, ready for VHP, ModBus RTU compatible
- **Low maintenance and service-friendly:** Automatic "real" oil change, long maintenance intervals
- **Made in Germany**



COMPACT



HIGHLY EFFICIENT



QUIET



READY TO CONNECT



REMOTE INTERNET



RUNTIME OPTIMIZATION



PROCESS HEAT



LOW-MAINTENANCE