

Analogue display with stepper motor

- For use in ships and rail vehicles
- Typical applications:
Thrust direction and rudder position display
- Propeller adjustment angle, RPM display
and speedometer
- LED scale and indicator illumination
- Accuracy class 0.5
- Non-sensitive to shocks and vibrations
- General purpose use



Connections and Dimensional Drawing

Connections:

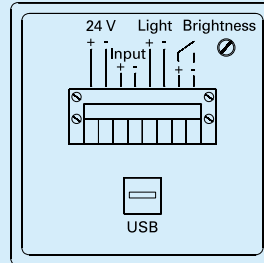

Dimensional Drawing:

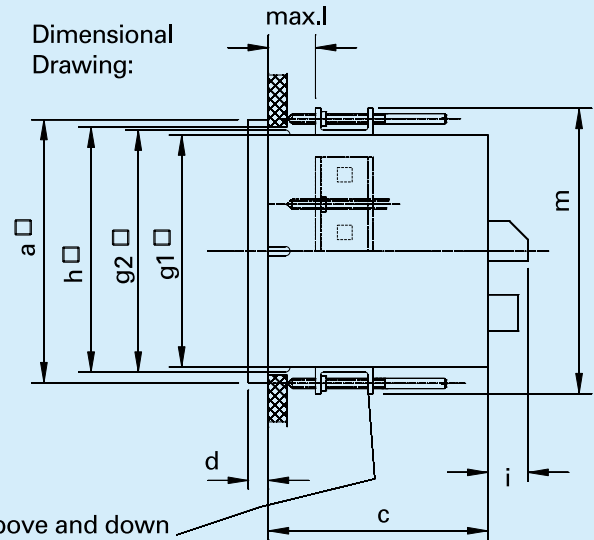

Device mounting above and down or on the left and on the right

Type:	a □	g1 □	g2 □	c	d	m	max.l	i	Cutout h □
SM 72	72	66	67,5	70	5,5	82	15	7	68+0,7 x 68+0,7
SM 96	96	90	91,5	53	5,5	106	16	11	92+0,8 x 92+0,8
SM 144	144	136	137,5	57	7,5	152	14	13	138+1 x 138+1

- Analogue display units
- Measuring transducers
- Digital measuring instruments
- Appliance testers
- Contact devices
- Text displays / printers
- Bar graph displays
- Probes
- Accessories

Product Table



GMW **GOSSEN**
Müller & Weigert

GOSSEN Müller & Weigert

Kleinreuther Weg 88
D-90408 Nuremberg, Germany
Phone: +49(0)911 35 02-0
Fax: +49(0)911 35 02-3 07
Internet: <http://www.g-mw.de>
e-mail: info@g-mw.de