

INKOMA-cruciform disc coupling KSO (Oldham design) are machine elements for the smooth transmission of torque between input and output. The coupling can accommodate parallel off-set of the connected shafts as well as angular deviation. The values for the deviations during operation must remain within the permitted limiting values for the coupling.

The INKOMA-cruciform disc coupling KSO has the following important features:

- rotationally stiff shaft connection with compensation for radial and angular offset
- provides synchronous transmission whilst radially offset
- extremely high torque transmission
- simple assembly and disassembly
- simple and economical exchange of the wear element (cruciform disc)
- good fail safe characteristics due to special materials

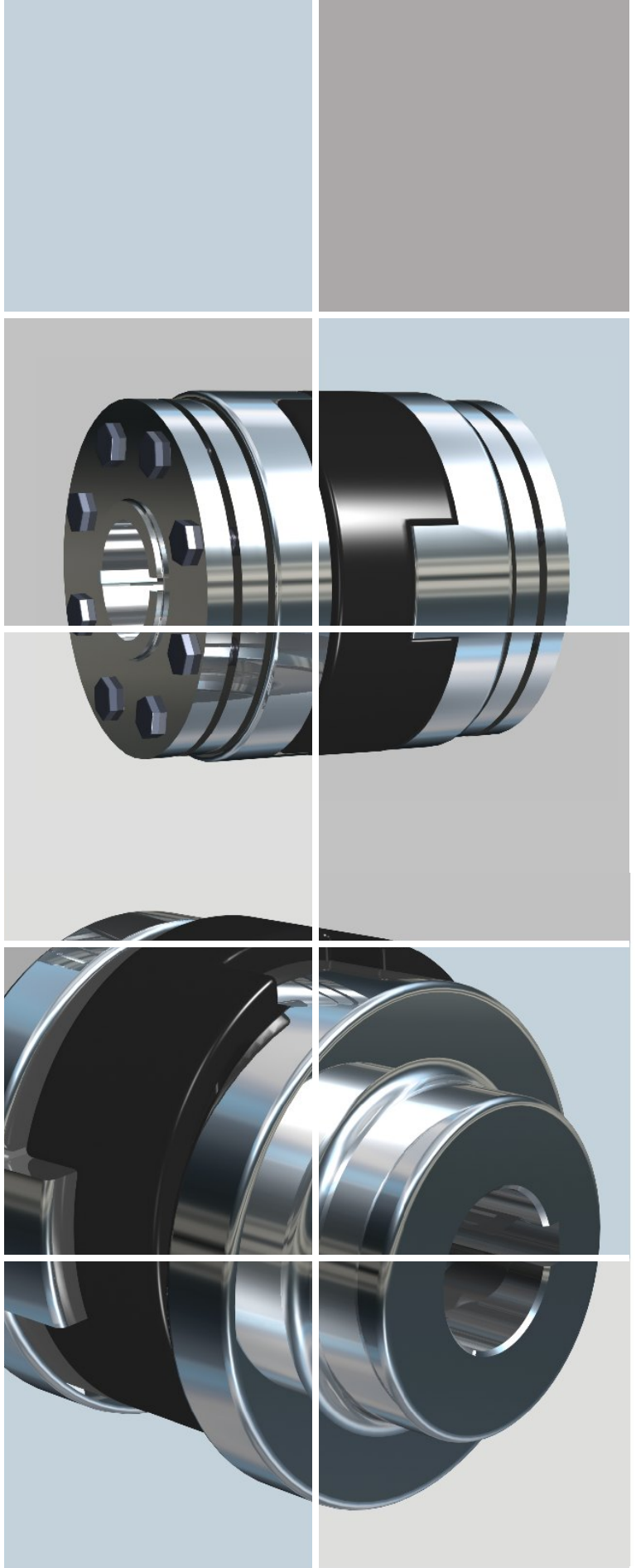

The INKOMA-cruciform disc coupling KSO is available in the following versions:

A1 = Flange version:

Both outer discs have fixing holes for socket head cap screws for connecting components.

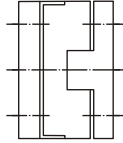

A2 = Hub version:

Both outer discs have finished bores in outward facing hubs and keyways to BS 4235 (DIN 6885/1).

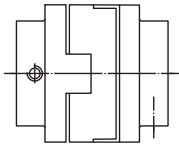

A3 = Tension hub version:

Hub version with additional shrink disc (ISR-A). The shrink disc allows keyless fitting to the shaft.

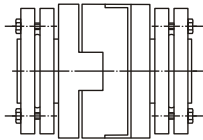

A7 = Split hub version:

This hub version has two components - a fixed and a removable part allowing radial clamping to the shaft, it also has a keyway to BS 4235 (DIN 6885/1).

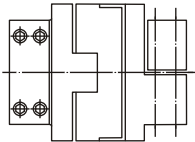

Combinations:

Each coupling can combine any of these versions. E.g. A1/A2 - one side with flanged version with fixing holes for socket head cap screws and the other side with outward facing bored hub with keyway to BS 4235 (DIN 6885).

Special versions:

In addition to basic versions, customer specific executions are also possible e.g. incorporating sprocket, gears, shaft, etc. in the outer discs.

Order code	Radial offset $\pm R$ [mm]	Angular misalignment $\pm \alpha$ [°]	Static torque T_{stat} [Nm]	Inertia $J^{2)}$ [kg cm ²]	max. operating speed $n_{max}^{3)}$ [1/min]	Torsional stiffness ⁴⁾ [Nm/rad]
KSO-6	0,15	0,5	0,8	0,0006	3000	10
KSO-9	0,15	0,5	3	0,0018	3000	30
KSO-13	0,15	0,5	5	0,0026	3000	65
KSO-19	0,2	0,5	12	0,0067	3000	115
KSO-25	0,25	0,5	15	0,0255	3000	205
KSO-33	0,25	0,5	50	0,1140	3000	620
KSO-41	0,25	0,5	55	0,3327	3000	1200
KSO-60	0,25	0,5	65	1,2410	3000	2620
KSO-75	0,5	1	80	16,050	1500	8050
KSO-105	0,5	1	480	79,100	500	13200
KSO-125	0,5	1	700 ¹⁾	185,07	500	23100 ¹⁾
KSO-150	1	1,5	910 ¹⁾	397,00	500	31000 ¹⁾
KSO-175	1	1,5	1200 ¹⁾	721,30	350	40500 ¹⁾
KSO-200	1	1,5	2100	-	300	-
KSO-250	2	1,5	5100	-	300	-
KSO-300	2,5	1,5	10000	-	300	-

¹⁾ These values are valid for KSO with a bronze central coupler.

²⁾ for version A2- A2

³⁾ Dependent on offset, angular misalignment and lubrication.

⁴⁾ These values apply for 50% of the static torque, without angular or radial offset.



INKOMA - GROUP Headoffice

Sitz der INKOMA Maschinenbau GmbH
Neue Reihe 44
D - 38162 Schandelah - Germany

phone: +49/(0)5306-9221- 0
fax: +49/(0)5306-9221-50
e-mail: info@inkoma.de
internet: www.INKOMA-GROUP.com

Request our [complete catalogue](#) or visit us on the [Internet](#). You can obtain a free download of our brochure or the product drawing of the selected item using the [CADENAS](#) facility.