

MESYS

Calculation software for mechanical engineering

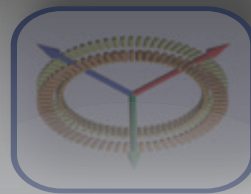
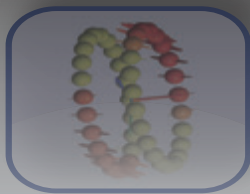
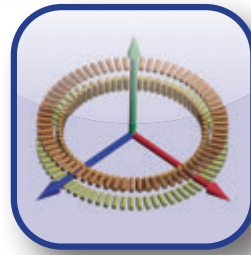
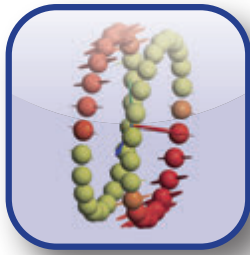
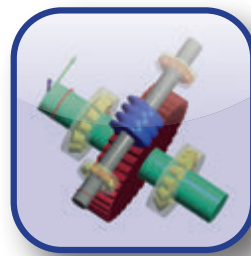

Calculation software for mechanical engineering

The company MESYS AG in Zurich offers calculation software for mechanical engineering, custom software development as well as engineering services.

Roller bearing analysis

- Load distribution
- Life according to ISO/TS 16281
- Influence of clearance, tilting angle, centrifugal forces, load spectra
- Track rollers with elastic outer ring
- Parameter variations

Shaft analysis

- With integrated bearing analysis and nonlinear bearing stiffness
- Strength according to DIN 743
- Natural frequencies
- Coaxial shafts
- Load spectra
- Parameter variations

Shaft systems

- Coupling of shafts by gear pairs
- Data exchange with gear calculations
- Calculation of rotational speeds
- Natural frequencies at system level
- Load spectra and gear shifts
- 3D elastic housings and planet carriers

Axial-radial cylindrical roller bearings

- FEM-based calculation for axial-radial cylindrical roller bearings
- Consideration of the ring deformations

Ball screws

- Calculation of the load distribution in ball screws under axial and radial loading as well as tilting moment.
- Calculation of life analogous to ISO/TS 16281
- Integration in shaft analysis
- Parameter variations

The software is available for windows in either 32 or 64 bit version as well as for macOS. Both the user interface and reports can be switched between different languages. In addition to English, German, French, Spanish, Chinese and Korean are supported.

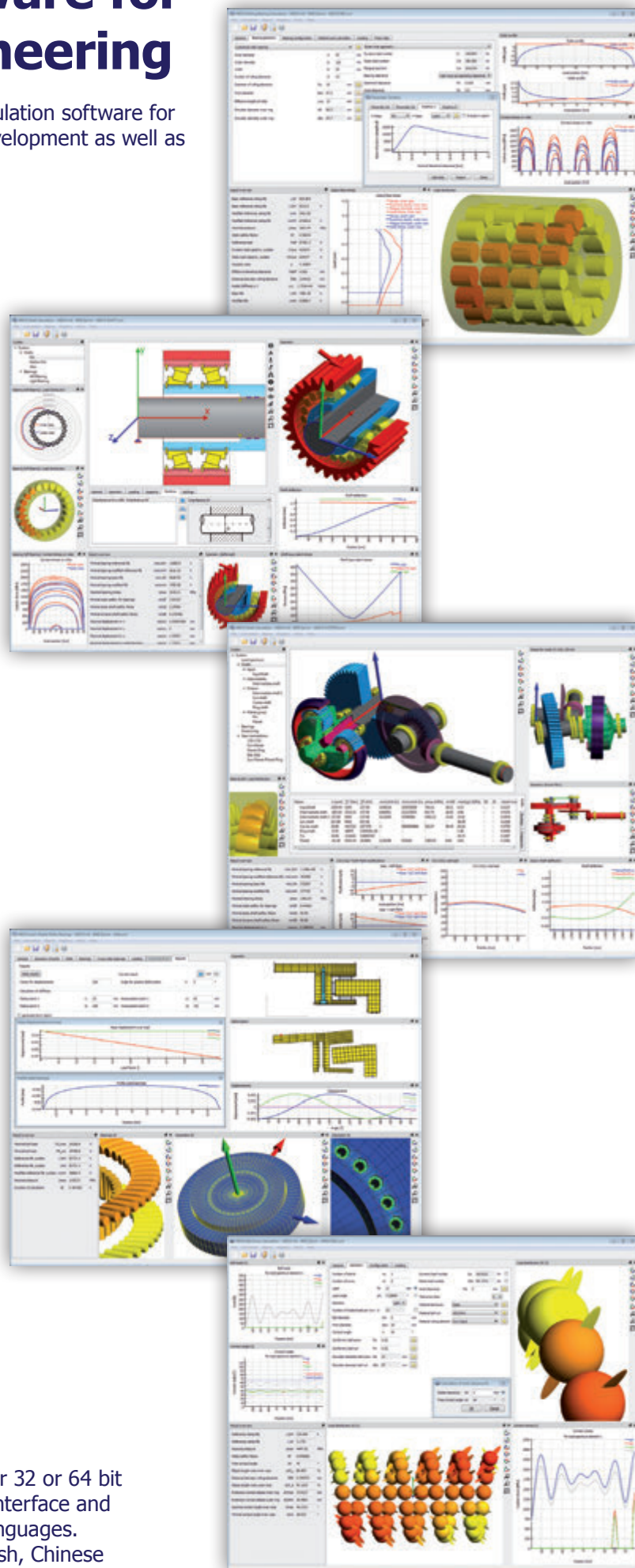

Bearing calculation according to ISO/TS 16281

The bearing life calculation according to ISO/TS 16281 (2008) is the latest standardized version of a bearing life calculation. The bearing life is calculated using the load distribution on each rolling element and is therefore not limited to an external force but can also consider tilting moments and the influence of clearance or pretension. For each of the five degrees of freedom either a load or a displacement/rotation can be specified. As with the classical calculation according to ISO 281 the influence of the lubricant in the life expectancy can be also considered.

The software is considering the following effects:

- Bearing clearance
- Change of clearance through thermal effects
- Change of clearance due to fits
- Roller profile
- Centrifugal loads
- Life reduction due to reduced hardness
- Lubricant and Lubricant film thickness
- Load spectra
- Bearing sets (of several bearings)
- Hybrid or ceramic bearings
- Reliability
- Elastic deformations of the outer ring for track rollers as extension module

As results you will get

- The load distribution in the bearing
- The Hertzian contact stress
- The stresses below the surface for determining the required hardness depth
- The load dependent friction moment for ball bearings
- The contact angle under load
- The displacement and tilting of the bearing
- The minimal film thickness
- The spin-to-roll ratio
- The extent of pressure ellipse
- The load distribution in a set of bearings

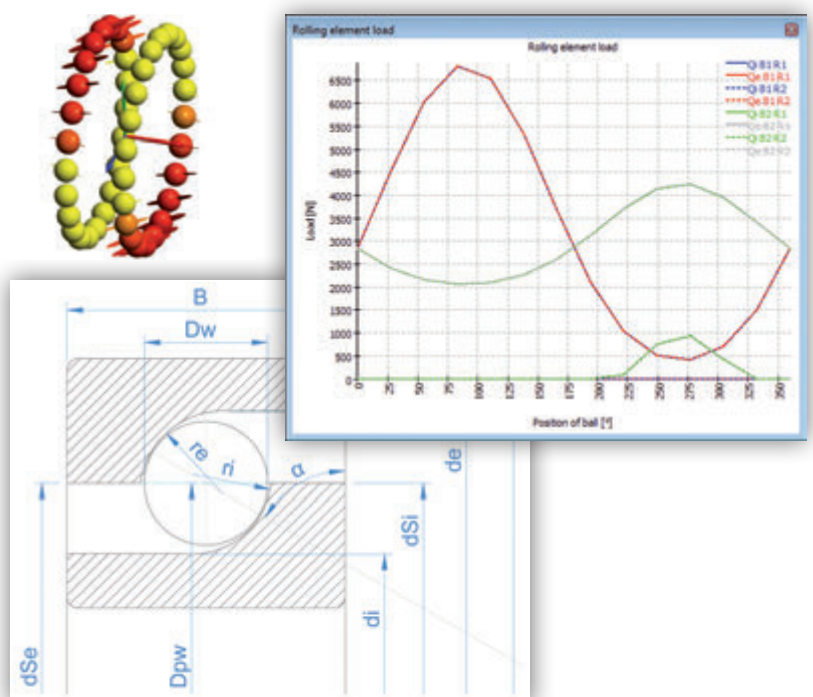
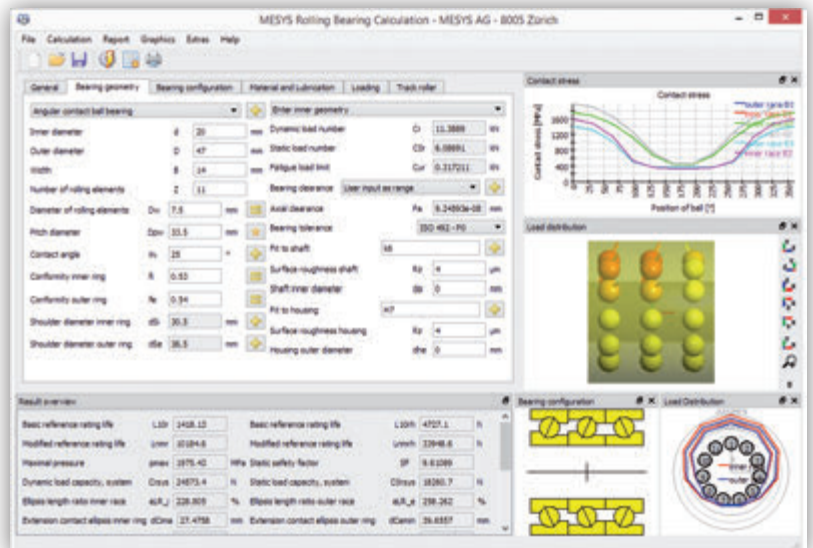
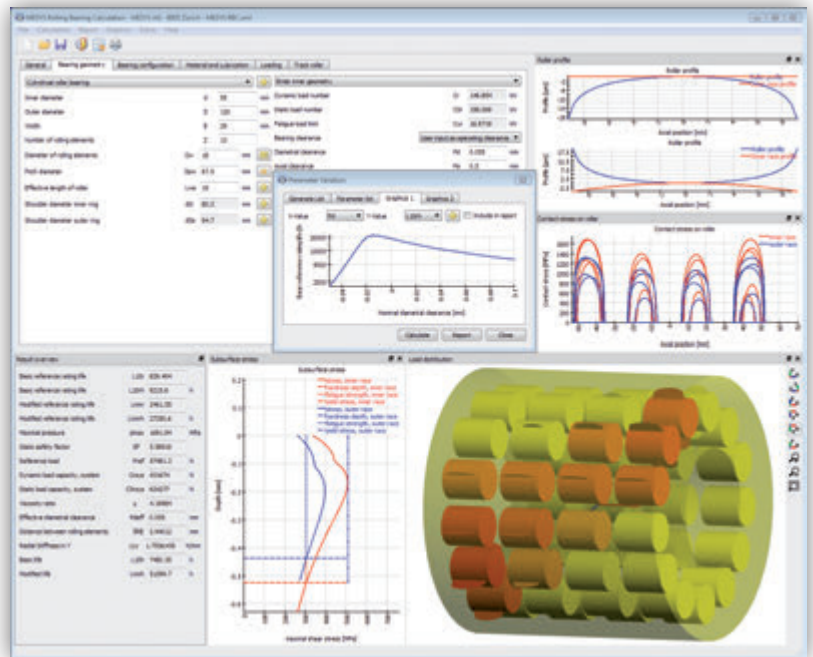

Typical applications

Single bearing under tilting moment

Generally, the tilting moments are to be avoided on a bearing, but in track rollers or slewing rings the tilting moment can be the main load.

For roller bearings the influence of tilting on the load distribution or life can be checked.

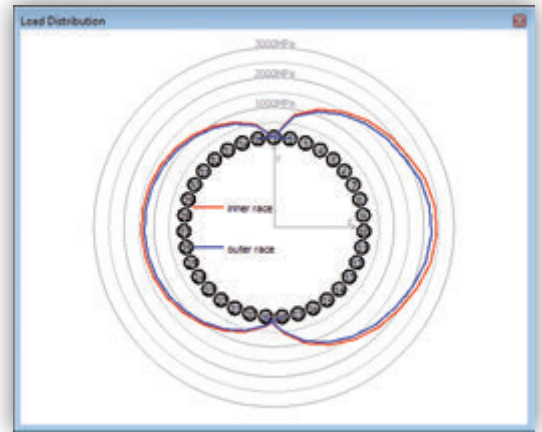

Sets of angular contact bearing

Angular contact bearings are often used in sets, but the load distribution between the single bearings is difficult to assess. Using the software the load distribution, life and stiffness can be calculated in dependency on the pretension of the bearing set. The pretension can be individually set for each bearing.

This also allows the user to check if the pretension is large enough and whether the bearings get load in each load case or not.

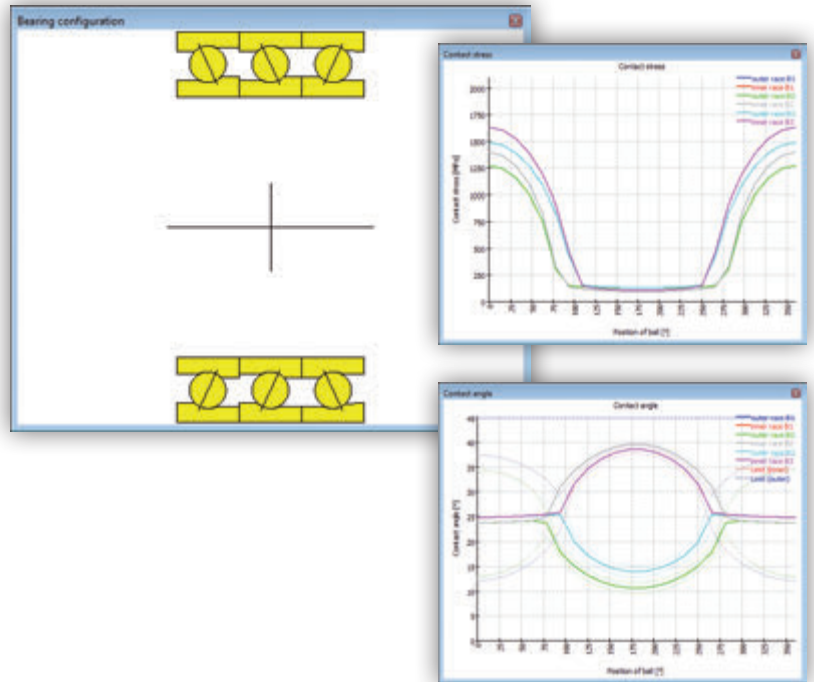

Influence of clearance and pretension

The influence of bearing clearance and pretension of bearing life and load distribution can be evaluated. The nominal clearance can be selected among the classes C2..C4 according to standards or directly provides as a numerical value. The bearing tolerance class can be selected as P0..P2 and the tolerances of the shaft and housing according to ISO 286. It is also possible to specify the fits as numerical values directly. The change of clearance because of fits, thermal effects and centrifugal loads then determines the operating clearance.

With the help of the parameter variation, the influence of the clearance in the bearing life and pressure can be clearly represented.

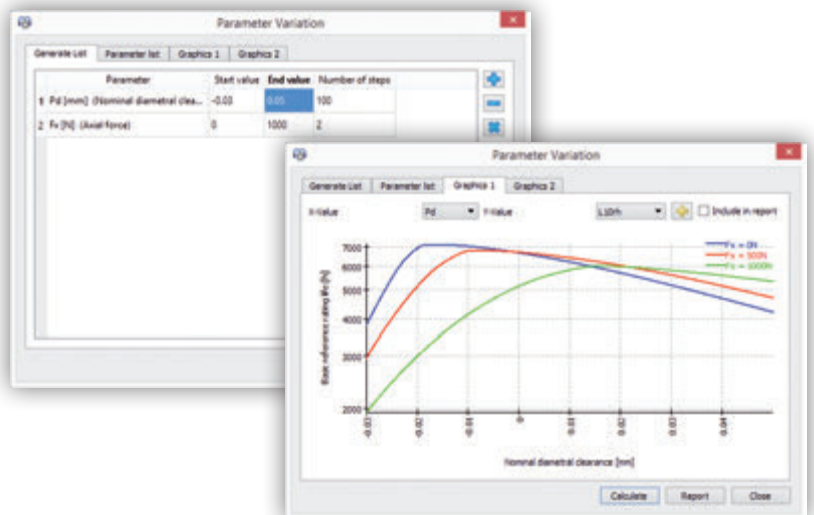

High speed

In most instances, the bearing inner race is higher loaded than the outer ring. For high speed this can change because of centrifugal load. The contact angle will be changed too.

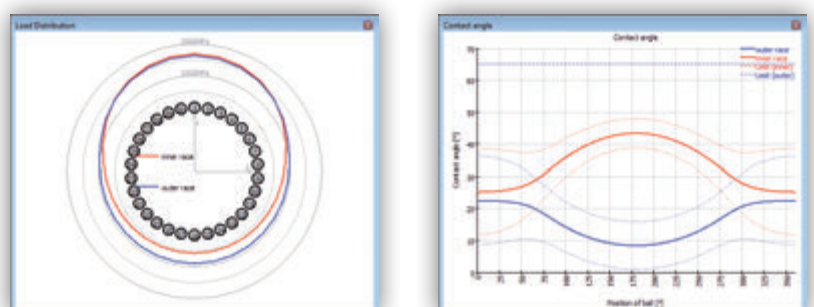

Support of a planet gear using several cylindrical roller bearings

Planetary gears in planet gear sets can be supported using several cylindrical roller bearings. Using helical gears will lead to a tilting moment in addition to the radial load. This tilting moment has to be supported by the bearing set. The bearing clearance has an influence both on the tilting angle, which should be minimal for the gear contact, and on the load distribution within the bearing, in which the tilting should also be avoided. Here an example of the load distribution in a set of three cylindrical rolling bearings with different clearance is shown.

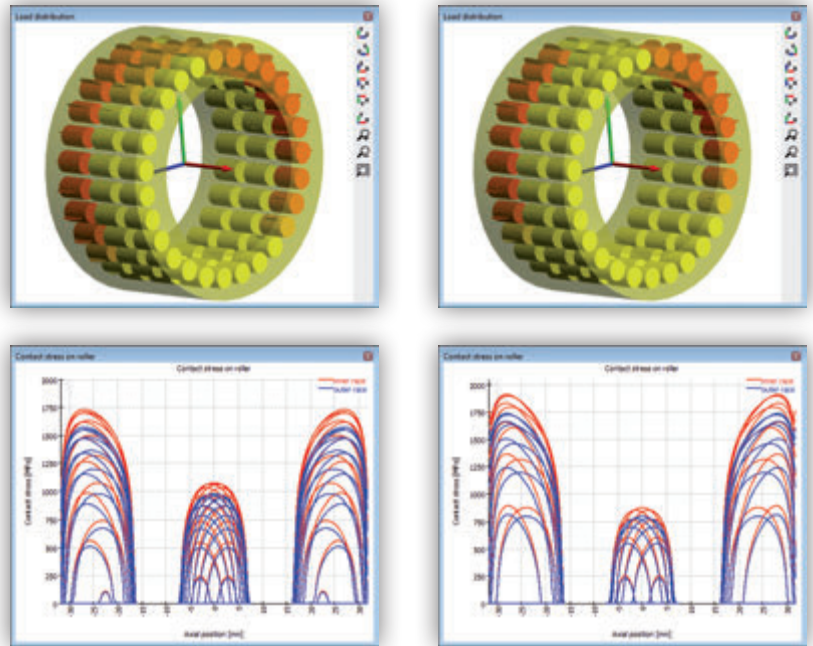

Slewing bearings with four point bearings

Different bearing types are used for large slewing rings: Four point bearings with one or two rows and roller bearings having three sets of rollers.

The configuration with one or two row four point bearings can be analyzed using the software.

Important results are the contact stresses, the friction torque, and the shear stress below the surface to determine the necessary hardness depth.

Reduced hardness of the races will be taken into account according to NREL DG03 guideline for the calculation of life and static safety.

The contact stress is calculated on all four (or eight) contact points. So you will see if and how often a 4 point contact occurs.

Several load cases can be considered in one calculation using load spectra.

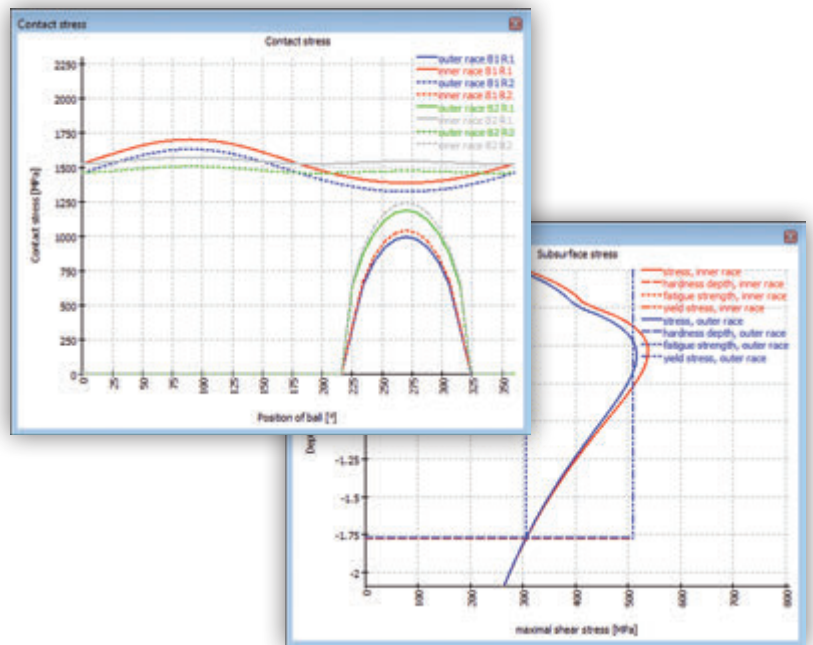

Define load rating diagram

Points per line:

Tolerance: %

Calculate moment load M_z over axial load F_x
 Calculate axial load F_x over moment load M_z
 Calculate radial load F_y over axial load F_x
 Calculate axial load F_x over radial load F_y

Type	Value
1 Static safety factor (SF) [-]	1
2 Basic reference rating life (L10r) [-]	0.2

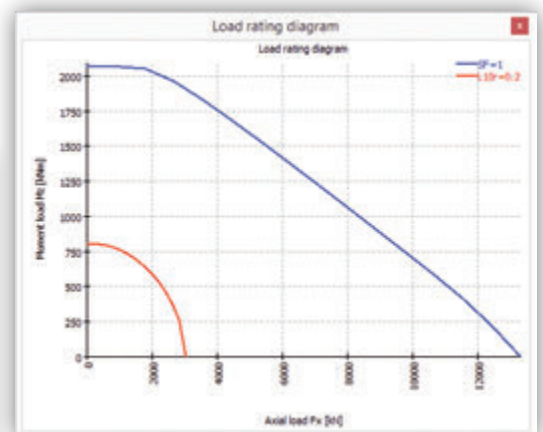

Specialties for track rollers

In contrast to bearings whose outer ring is supported by the housing, no such support is available for track rollers. The load is introduced on a point on the outer ring. The outer ring is deforming which is also the reason for usually stiffer outer rings as in normal bearings.

The bearings analysis software extension for track rollers allows the definition of outer ring geometry and loading in radial and axial direction on several locations on the outer ring. The load distribution is then calculated considering the elastic deformations of the outer ring.

Multi-row bearings are supported. In the current version an elastic outer ring can be considered for radial deep groove ball bearings, radial angular contact bearings, radial four point bearings and radial cylindrical roller bearings.

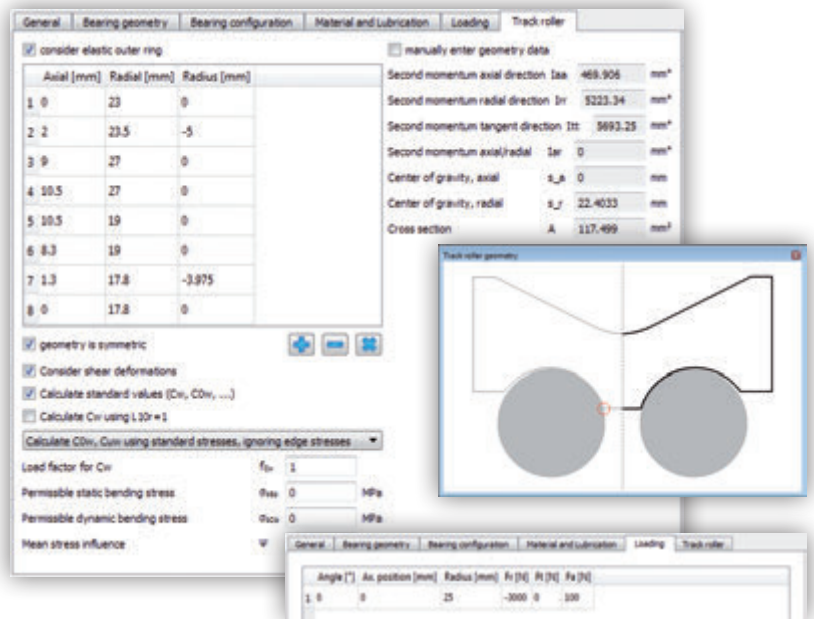

Effective load capacities

In catalogues for track rollers often reduces effective load capacities are provided, which are considering the different load distribution. They are calculated by the software in addition to maximal permissible radial load. It is important to consider that the loading should be considered at a location of a rolling element for the calculation of load capacities, but between two rolling elements for calculation the maximal permissible radial load.

Geometry und loading

Outer ring geometry can be defined as a polygon and radii. Also unsymmetrical cross sections are possible. The second moments and the position of center of gravity are calculated or they can be provided by the user directly.

The loading of the outer ring can be specified on several locations: The only restriction is a zero torque on the bearing.

Results

As results the same values as for rigid bearings are calculated. Additionally, for track rollers, the effective load capacities, the permissible radial load, the stresses in outer ring and the deformations of outer ring are given as well.

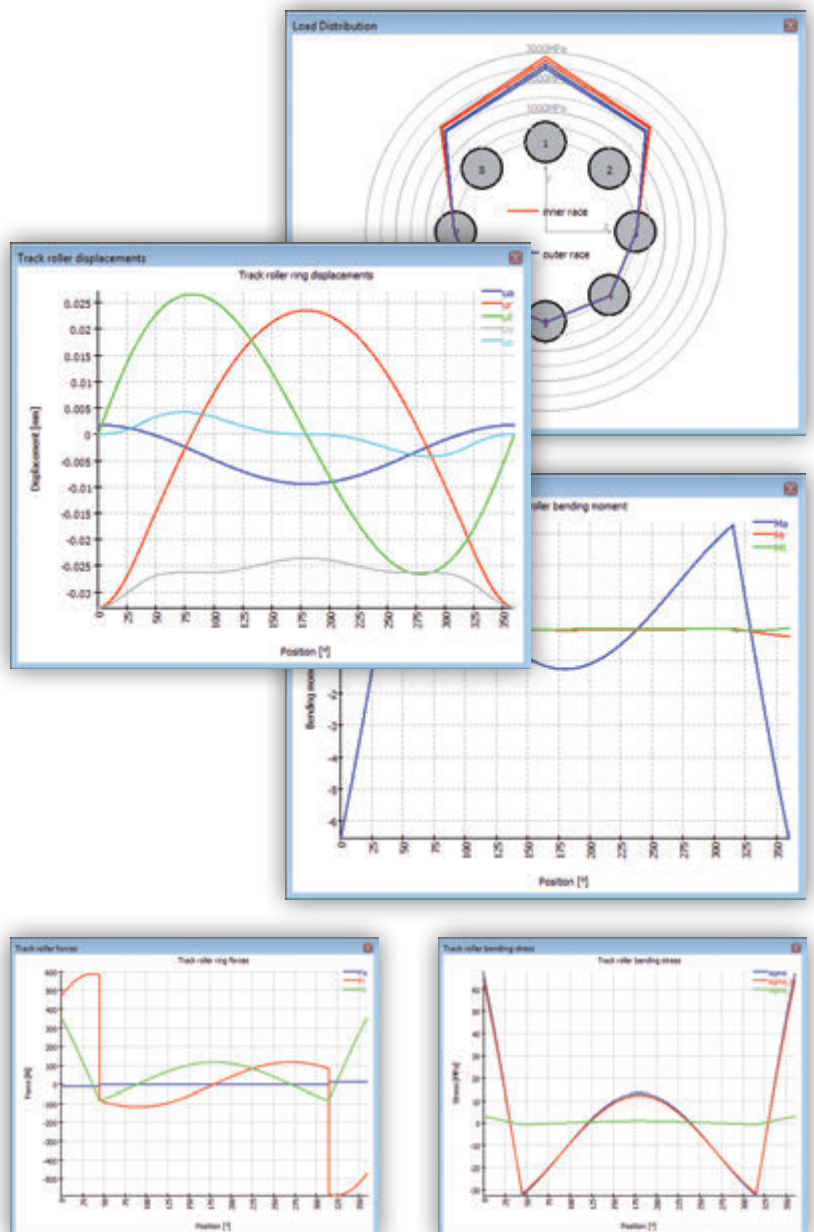

MESYS Shaft calculation

The shaft calculation allows the calculation of displacement, forces, strength according to DIN 743 and bearing life for several connected coaxial shafts. The MESYS Rolling Bearing Calculation according to ISO/TS 16281 is included in the software and the nonlinear stiffness of rolling bearings is considered.

Because of the nonlinear bearing stiffness, shafts with more than two bearings can be calculated with accurate bearing forces as result. Pretension of bearings can be considered. Combinations of angular contact bearings can be easily considered as bearing set.

Shaft geometry can be defined using an arbitrary number of cylindrical and conical elements for inner and outer geometry. The geometry input is done using tables.

Loads can be specified as central or excentrical forces or as complex load elements like a gear.

Boundary conditions are some rigid constraints, springs, constraints with offsets, clearance and stiffness or a rolling bearing. There is no restriction in the number of loads or constraints. Also the housing stiffness can be taken into account. Either as coupled stiffness matrix or by CAD-import of a housing.

Several coaxial shafts can be defined and connected by rolling bearings or general supports. Shear and axial deformations are considered, a nonlinear shaft model can be used optionally.

A parameter variation makes possible the automatic variations of preselected parameters and a graphical representation of the corresponding results.

Results are provided in a results overview, an additional table for bearing results, several graphics and a PDF report which also includes graphics.

Load spectrum

A calculation can be run using load spectra. The elements in the load spectrum can be chosen from load elements, speeds and temperatures. Moreover, any single case belonging to the whole load spectrum can be run independently.

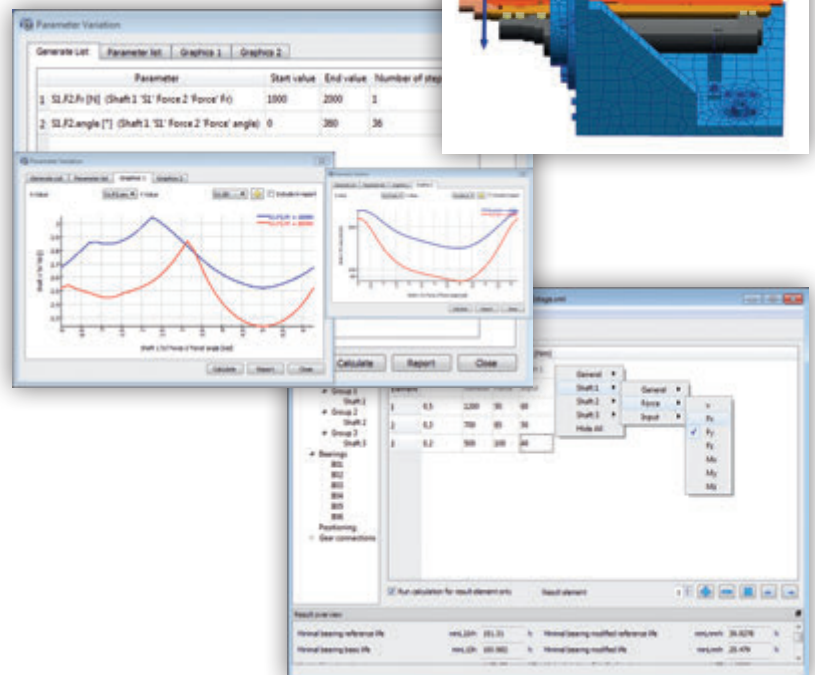
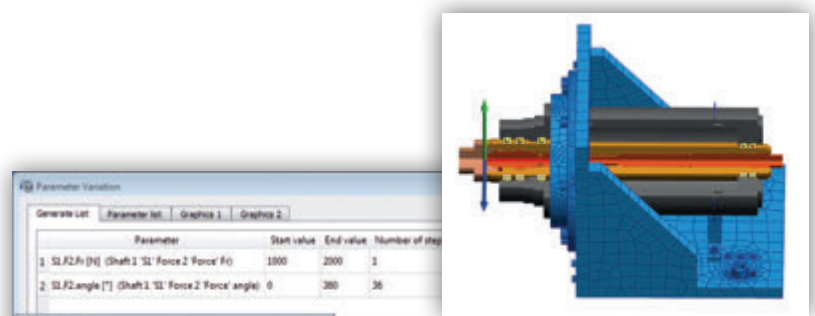
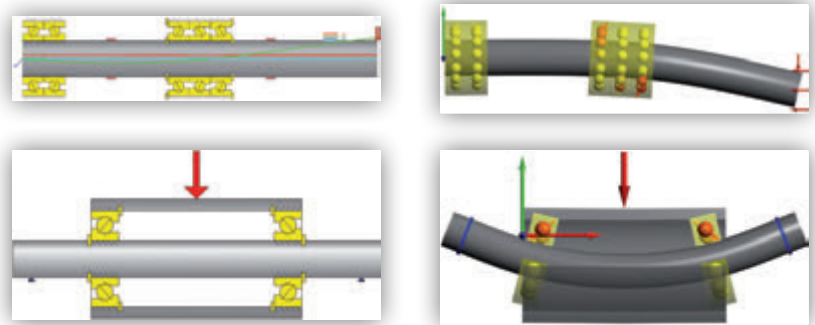
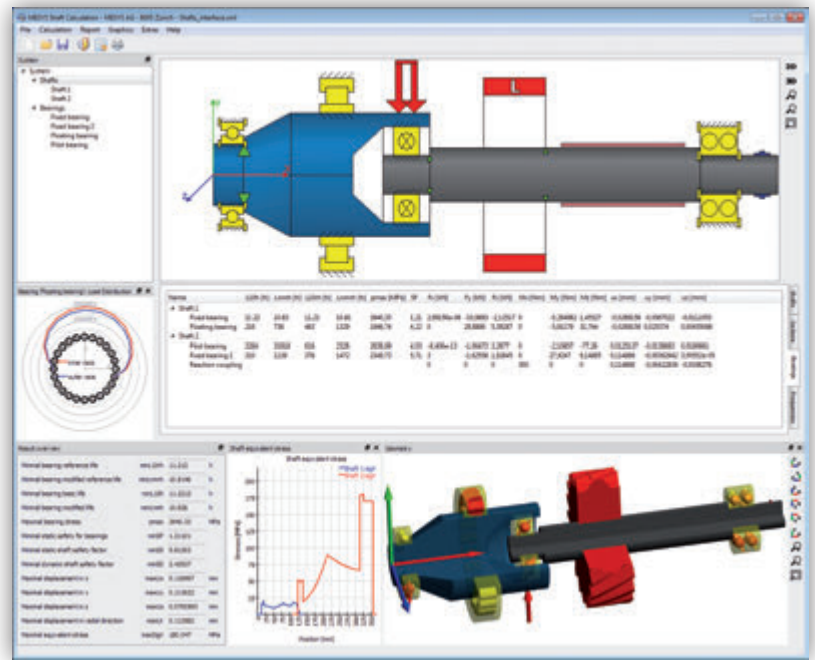

Strength calculation

Shaft strength can be calculated according to DIN 743 (2012). All notch factors of the standard can be selected in the software. In calculations with load spectrum either a calculation for infinite life for each load can be run or a calculation with an equivalent amplitude according to DIN 743 part 4.

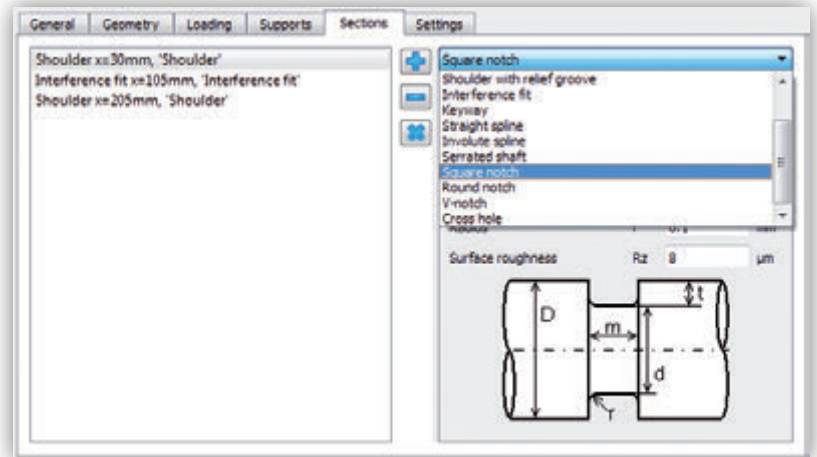

Natural frequencies and mode shapes

Natural frequencies are calculated considering bending, axial, and torsional modes. These modes can be coupled, like seen here for an axial mode (red) with a bending mode (blue), because of the bearing stiffness.

Additional masses can be defined for each shaft. The gyroscopic effect can be considered and a Campbell diagram is also provided in the software. In addition to the 2D visualization, also a 3D animation is available.

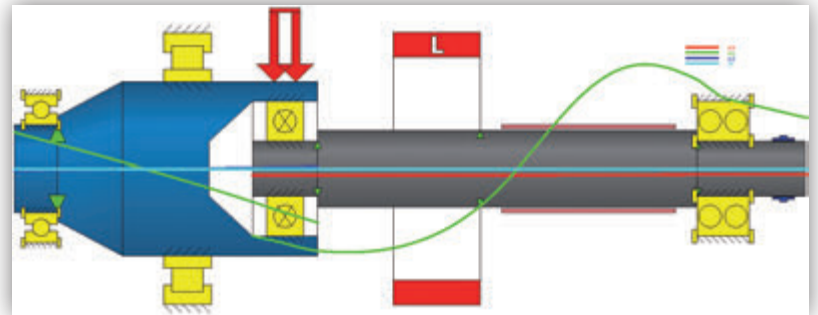

Campbell Diagram and harmonic response

The speed dependency of natural frequencies can be shown in a Campbell diagram. Axial, torsional and bending modes are shown in different colors for better understanding. The critical frequencies are shown in an additional report.

The harmonic response to periodic loads like unbalance is calculated and can be shown over speed or over time

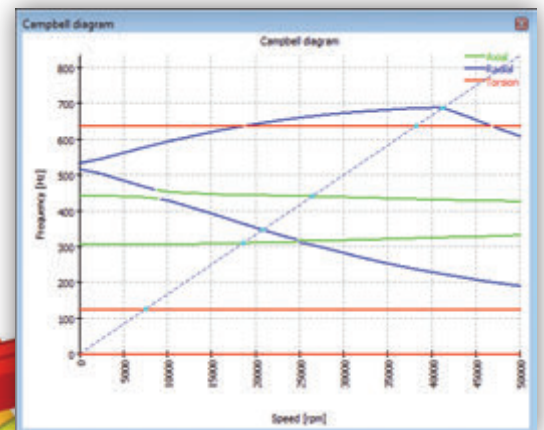

Planetary gear on a flex pin

An example for the usage of several coaxial shafts is the support of a planetary gear using a flex pin. A pin is fixed in the planet carrier on the left side. On this pin there is a hollow shaft which is connected to the planetary gear with taper roller bearings in this example. As seen in the diagram for deflection, the gear stays horizontal and just moves horizontally because of the configuration. Because of the central loading both bearings carry the same load. The axial load is introduced by contact angles of the bearing.

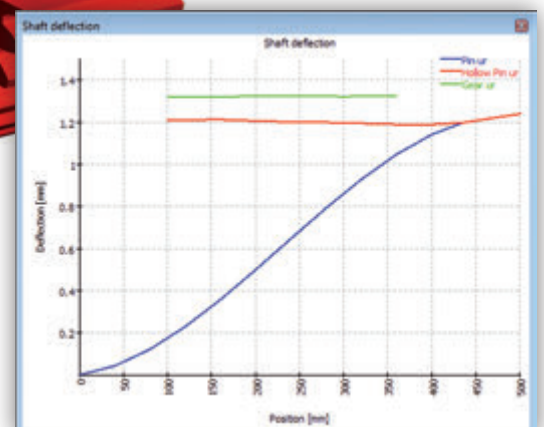
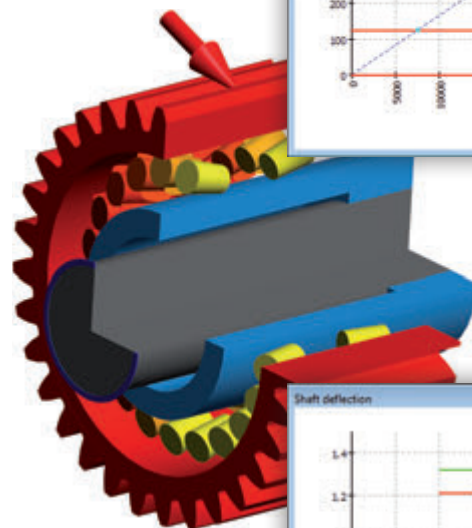

MESYS Shaft systems calculation

The shaft calculation can be extended to include the calculation of shaft systems. One one hand a version limited to parallel shafts coupled by cylindrical gears is available, on the other hand shaft systems with arbitrary direction coupled by planetary gear sets, bevel or worm gears are possible.

The rotational speeds of the shafts are calculated on the basis of the couplings. In a calculation with load spectrum it is only needed to define the input values; all the inner forces and rotational speeds are calculated. Shift gearboxes can be taken into account by means of the so-called "Configurations" in the software.

The following results are available:

- Rotational speeds for shafts
- Torques in gear pairs
- Safety factor for shaft strength according to DIN 743
- Safety factors for gears (calculated through external programs)
- Bearing life according to ISO/TS 16281 and ISO 281
- Elastic curve and force diagrams in each shaft

Coupling by gears

Besides the existing input values for gears at the force element dialog under shafts, additional data fields regarding gear pairs are available at the connections page. Cylindrical gears can be considered as a line load with predefined mesh stiffness. The load distribution along the tooth width provides a clue on the necessary flank modifications, which can be undertaken in the software.

The gearing data can be exchanged with gear calculation programs. The safety factors are updated in the background during each calculation and are displayed at the results overview. The interface of the gear calculation programs accessed from shaft system calculation and all the corresponding information is saved together the shaft system data.

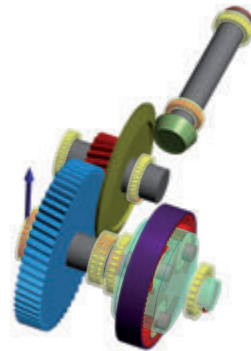
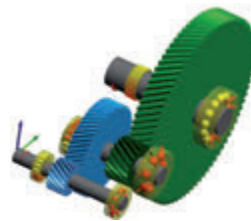
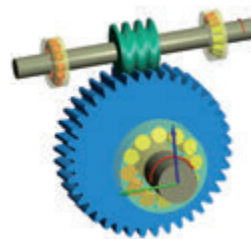
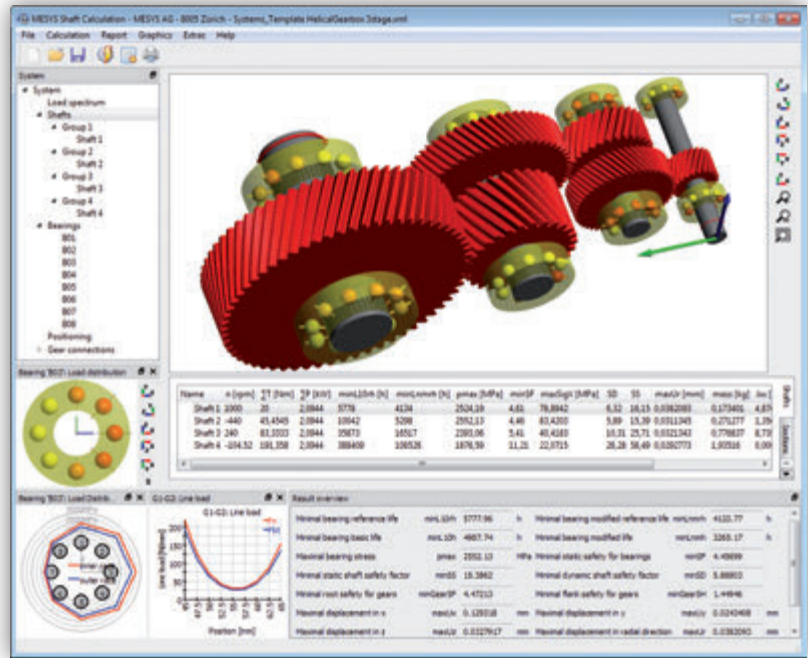

Color	Color			
Shaft	Input	Intermediate		
Gear	G1	G2		
Position	202,5	135,5	mm	
Number of teeth	15	26		
Width	53	53	mm	
Profile shift coefficient	-0,0403	-0,0403		
Normal module		mn	6	mm
Normal pressure angle		α _n	20	°
Helix angle		β	30	°
Helix direction	Helix left han	Helix right har		
Center distance		a	141,54	mm
Cumferential backlash		j _t	0,1	mm
Gear mesh stiffness		C _y	20	N/mm/μm
Calculation	TBK 2014			
Tooth flank modifications				

	Gear 1 right flank [mm]	Gear 2 right flank [mm]
Flank line crowning CP	0,023	0
Flank line slope modification CHB	-0,046	0
Flank line end relief amount I CBI	0	0
Flank line end relief length I LCI	0	0
Flank line end relief amount II CBI	0	0
Flank line end relief length II LCI	0	0

Symmetric modifiers for gear 1
 Symmetric modifiers for gear 2

OK Cancel

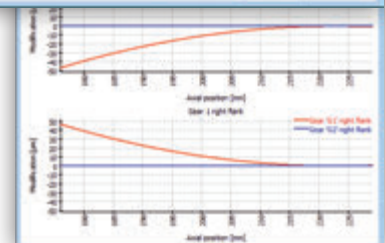
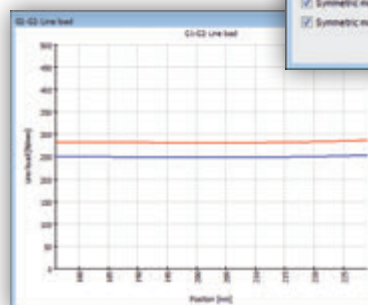

Planetary stages

All the planets of a planet stage are considered in the calculation. Therefore, the sun can be centered by means of the planets. The load sharing among the planets arise from the loads, deformations and mesh stiffness.

Planet carriers can be considered as 3D elastic parts defined by parameters or by CAD import.

Positioning

Different conditions can be defined for the positioning of groups, shafts and gears. In this way the shafts can be automatically positioned at the proper distance in accordance with the gearing data.

Configurations

The so-called configurations allow the user to activate and deactivate any coupling conditions previously defined. With this option the gear shifting of a gearbox can be simulated and considered. Each created configuration can be then selected in a load spectrum as if it was a load case.

Natural frequencies on system level

Frequencies can be calculated on system level too. Gear pairs lead to a coupling of axial, torsional and bending modes. Mode shapes can be animated in the 3D view. 3D elastic housings can be considered by modal reduction.

Results

The results are shown at different levels. There are results for the system such as the minimum safety factors for the shaft strength and gears, or the minimum life expectancy. Additionally, there are also results overviews for each bearing, group, shaft and its corresponding analyzed cross sections.

Besides the report for the shaft system, which contains the main results of bearings and gear calculations in table form, it is also possible to generate a full report. The full report contains detailed results for each bearing and each gear pair.

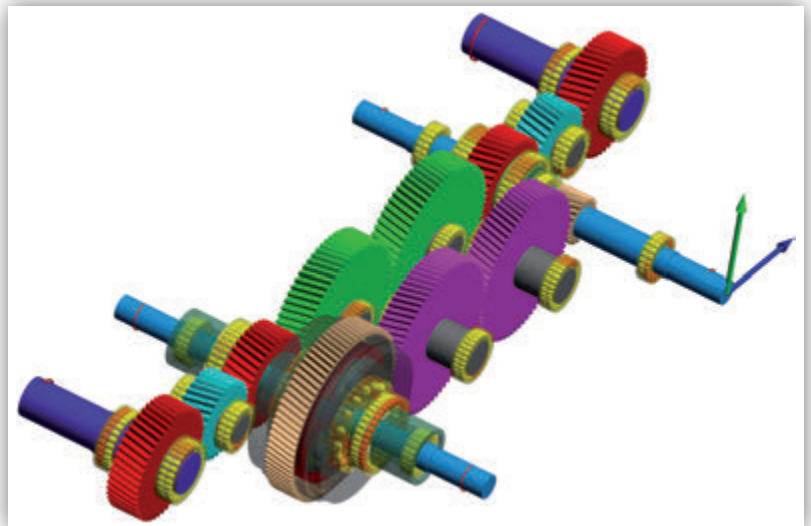
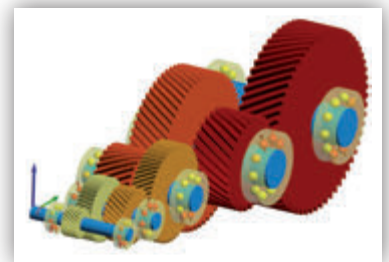
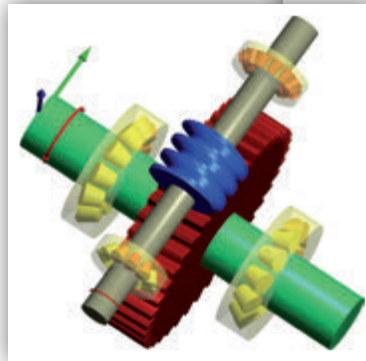
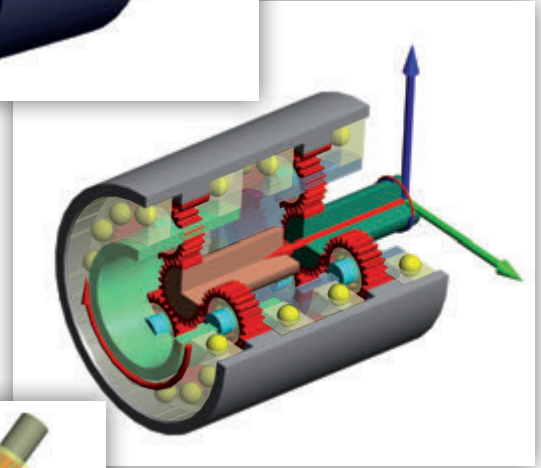
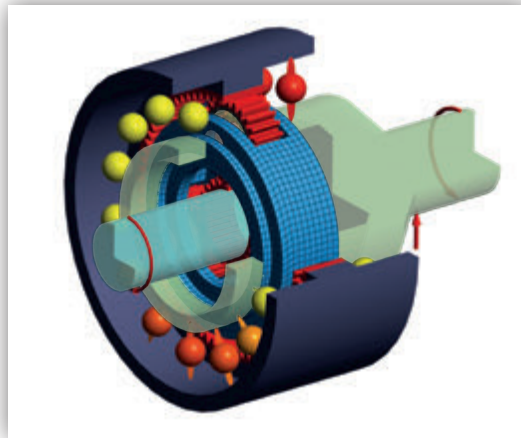

Name	L10h [h]	Lnmh [h]	L10sh [h]	Lnmsh [h]	pmax [MPa]	SF	Fx [kN]	Fy [kN]	Fz [kN]	Mx [Nm]	Fy [Nm]	Mz [Nm]
Input												
Fixed 1	1864	12975	2348	22787	2661.51	3.93	-7	-3,45012	-4,56675	0	70,9758	-49,3255
Floating 1	12624	79769	39675	198610	1834.38	4.75	0	-1,6019	-7,59944	0	-4,0218	1,17074
Intermediate												
Fixed 2	64320	926288	178172	971834	1620.59	6.03	-5,13333	-2,21418	15,2794	0	-0,599061	-0,0869705
Floating 2	6089	22275	13192	37225	2284.5	3.07	0	-1,72013	17,9024	0	21,53	2,55805
Output												
Reaction coupling							0	0	0	1892,8	0	0
Fixed 3	21825	413128	24981	526299	2217.92	6.79	-12,1333	-0,215938	-5,19207	0	-51,8783	9,76645
Floating 3	10259	36975	28223	91044	2122.66	3.55	0	8,86665	-15,8235	0	-11,6149	-4,68311

Result overview					
Minimal bearing reference life minLb	2247.67 h	Minimal bearing modified reference life minLm	22787.4 h	Minimal bearing basic life minL10h	1864.21 h
Minimal bearing modified life minLm	12675.2 h	Maximal bearing stress pmax	2661.51 MPa	Minimal static safety for bearings minG	3.06575
Minimal static shaft safety factor minG	9.50499	Minimal dynamic shaft safety factor minG	1.8109	Minimal root safety for gears minGe	6.73548
Minimal flank safety for gears minGe	1.31998	Maximal displacement in x maxLx	0.295108 mm	Maximal displacement in y maxLy	0.0295775 mm

Bearing calculation for axial-radial roller bearings

The calculation software for axial-radial cylindrical roller bearings considers deformations of the bearing rings based on a finite element calculation. The geometry of rotationally symmetric construction parts can be defined by means of polygonal lines by the user. It is possible to define an arbitrary number of cylindrical rollers.

The following bearing types are supported:

- Axial-radial cylindrical rolling bearing
- Radial cylindrical rolling bearing
- Crossed roller bearing
- Taper roller bearing

Additionally, the bolt pretension in one or several bolted joints can be considered. Loads can be defined either on surfaces or in singular points. For the definition of stiffness, a calculation of a series with variation of load and a load spectrum calculation are possible.

By means of multiple graphics and a PDF-report the following results are available:

- The load distribution on the rollers along the roller length as well as the load sharing among the rollers.
- The nominal and modified life expectancy for each bearing row and the system according to the ISO/TS 16281.
- The deformation and the stiffness defined through two arbitrary eligible points.
- The maximum and minimum bolt load.
- The graphical representation of the exaggerated deformations either in 3D or in 2D-view of the axial section in accordance with a chosen angle.

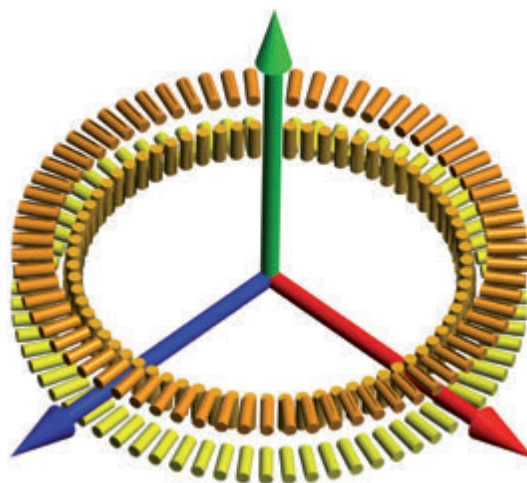
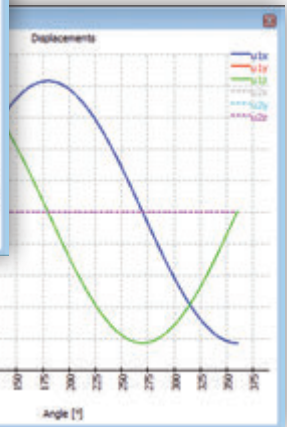
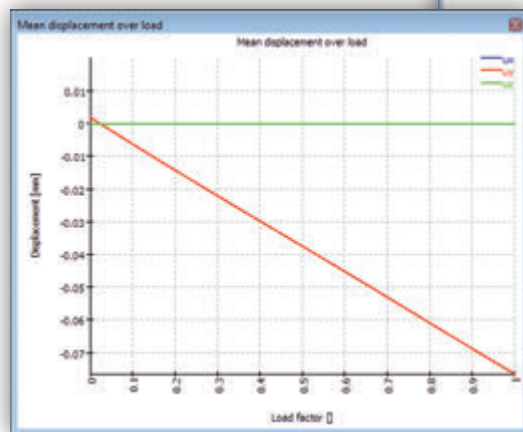
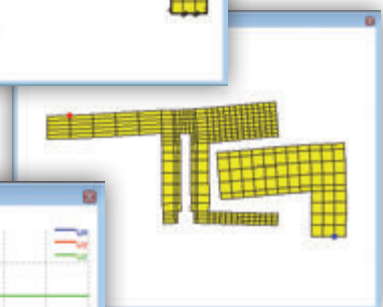
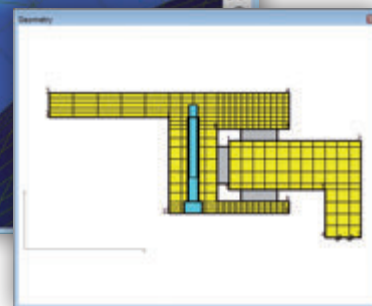
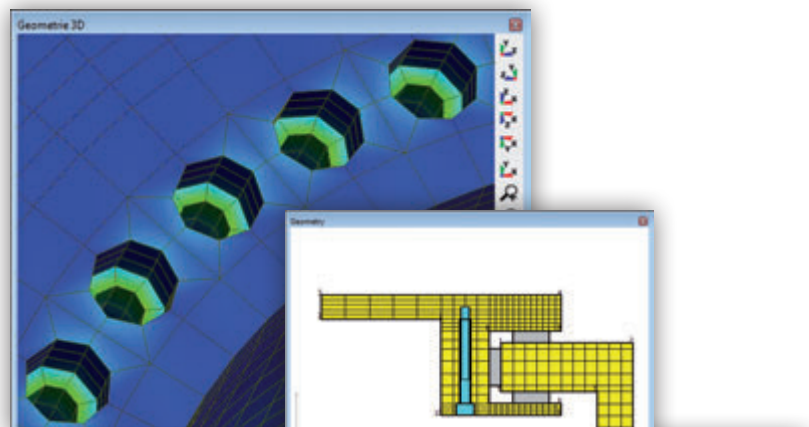
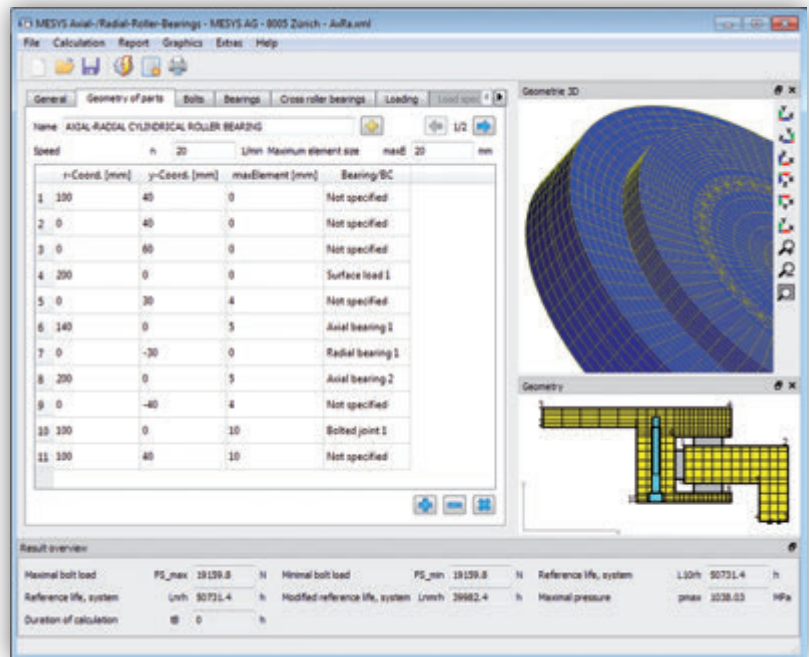

Calculation for ball screws

In most cases the loading of ball screws is purely axial. For this reason, the life expectancy according to ISO 3408-5 only considers axial loads.

The software calculates the load distribution in a ball screw as a result of axial and radial loading, and tilting moment. Based on the Hertzian pressure theory, the load distribution is calculated under the assumption of rigid screw and rigid nut by considering the contact stiffness of the balls. With the help of the software option "Configurations" it is possible to calculate prestressed nuts. The raceways can be design as gothic arches or full radii.

The life expectancy is resolved analogously to ISO/TS 16281 from the load distribution. The load capacities can be calculated either according to ISO 3408-5 or to a method analogous to the ISO 281/ISO 76.



A parameter variation allows an automatic combination and variation of input values and a graphical representation of the results.

The following results are available:

- Reference rating life according to ISO/TS 16281
- Load distribution between rolling elements
- Reaction forces/moments and displacements/rotations
- Contact pressure for each contact
- Contact angle according to the axial position of the ball
- Static safety factor

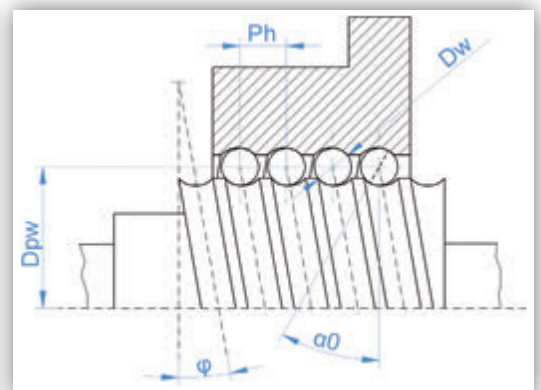
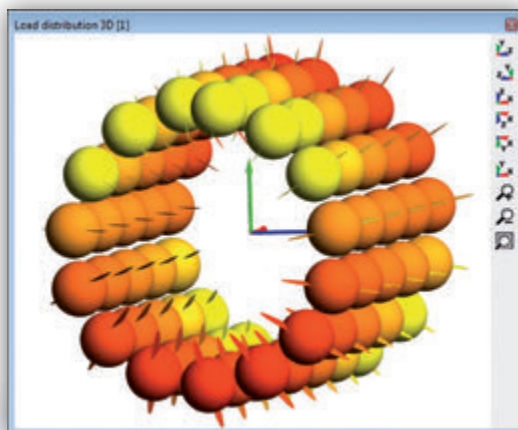
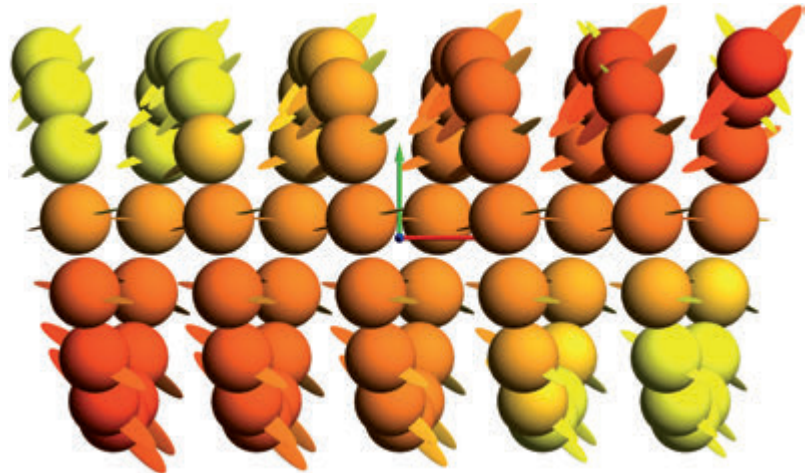

mesys
Engineering Consulting Software AG

MESYS AG
Technoparkstrasse 1
CH-8005 Zürich
T: +41 44 455 68 00
E: info@mesys.ch
www.mesys.ch