

Optidew Vision

Precision Dew-Point Meter

For laboratory or process humidity measurement with best accuracy and virtually zero drift, Optidew Vision combines latest sensor design with digital control technology.



Highlights

- Fundamental drift-free dew-point measurement
- Measurement Range: <0.5 to 100 %RH from -40 to +90°C ambient
- $\pm 0.2^{\circ}\text{Cdp}$ accuracy. Optional higher accuracy available
- High temperature sensor option to +130°C
- Rugged, NEMA-12 bench-top housing
- Display and output of multiple engineering units
- High pressure sensor option to 25 MPa (250 barg)
- Free application software

Applications

- Metrology laboratories
- Compressed air
- Environmental chambers
- Pharmaceutical
- Frost protection of turbine blades
- Fuel cell research
- Engine testing – high performance to commercial vehicle engines
- Power generation
- ... and many more

Optidew Vision Optical Dew-Point Meter

The Optidew Vision precision dew-point meter is based on the proven, fundamental optical dew-point measurement principle, giving long-term unmatched drift-free performance. It offers a wide measurement range from the equivalent of <math><0.5</math> to 100% RH at ambient temperature (dew point range: -40 to + 90°C, and up to 130°C with high temp option). Optidew Vision provides two linear 4-20 mA outputs and RS232 serial communications, allowing configuration and monitoring by a suitable computer or PLC system or via specific Optidew logging software. An adjustable isolated alarm contact means that Optidew Vision can be used for direct process control.

Laboratory or Process

The Optidew Vision is capable of withstanding most industrial conditions, while retaining the performance and sensitivity of a high-level reference hygrometer. Yet it is so easy to use. Simply connect the instrument, power up and Optidew Vision is ready to operate. The sensor is designed with a corrosion-resistant gold plated mirror and solid construction. The smart bench-top enclosure for the Optidew Vision has a handle that doubles as a stand. An optional panel-mounting kit is available for a permanent mounting.

Continuous Measurement

The power and sophistication of the Optidew Vision sensor and its digital control electronics, mean that there is no interruption in the data flow. Optidew Vision locks on to the actual dew point temperature of the gas being measured and stays there continuously. This means you can be certain your process is always in control regardless of fluctuations in gas temperature, pressure or humidity conditions.

Supreme Flexibility

The Optidew Vision is furnished with remote dew-point and temperature sensors that can be mounted in a variety of ways to suit the application – directly in the process, flange mounted, tee mounted, or by using a sample line. 'Best in class' depression together with cable lengths up to 30m and a pressure rating up to 2 MPa (20 barg) as standard – with optional high-pressure up to 250 MPa (25 barg) – makes almost any industrial application possible. Two sensor versions are available, with either single or two stage cooling. For extreme applications, a high temperature sensor version is available to +130°C.



Measurement Reliability – DCC (Dynamic Contamination Correction)

To minimize the mirror contamination in challenging applications, Michell engineered a totally new contamination compensation system for Optidew Vision. Dynamic Contamination Correction (DCC) automatically eliminates any optical error that may be caused by particulates on the mirror.



DCC is a self-learning system that adapts itself to operating conditions, predicts and reacts to the real requirements for contamination correction to achieve optimum transmitter performance at all times. Although the DCC system is fully automatic, it can be configured to accommodate your own process conditions.

For further protection in extreme conditions, sintered stainless steel or porous membrane sensor guard options are available. Either guard can also be used as a velocity limiter in high flow direct insertion applications.



Technology: Chilled Mirror

Michell's chilled mirror dew-point meters are precision instruments for critical measurement and control applications. The fundamental nature of this method means that chilled mirror instruments can be used as either extremely reliable and stable field instruments or as laboratory reference standards for the calibration of other devices. Michell's chilled mirror sensors are fundamental in their method of operation.

A miniature mirror is cooled by a solid state Peltier thermoelectric heat pump until it reaches the dew point of the gas under test. When this temperature has been reached, condensation will begin to form on the mirror surface. An electro-optical loop detects that condensation is forming, by a reduction in the intensity of light reflected from the mirror surface and through the control electronics of the chilled mirror instrument. This modulates the cooling power applied to the Peltier.

The mirror surface is then controlled in an equilibrium state whereby evaporation and condensation are occurring at the same rate. In this condition the temperature of the mirror (measured by a platinum resistance thermometer) is equal to the dew point temperature of the gas.

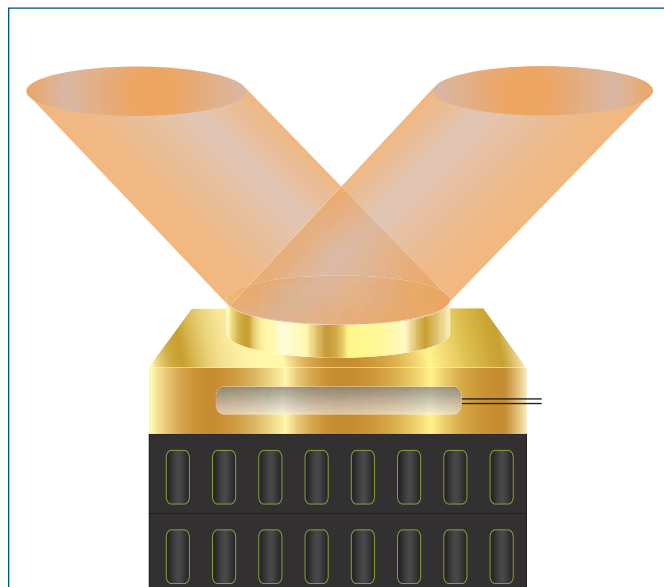

Technical Specifications

Performance	
Measurement range	
1-stage	-30 to +90°Cdp at sensor temperature of 20°C
2-stage	-40 to +90°Cdp at sensor temperature of 20°C
High temperature	-20 to +130°Cdp at sensor temperature of 20°C
Measurement accuracy	
	±0.2°Cdp
	±0.1°C temperature
	±0.15°Cdp accuracy optional
Measurement units	
	°C, °F dew point; %RH; °C, °F temperature; g/m ³ ; g/kg; a _w ; Δ (t - t dew point)
Response speed	
	1°C/sec plus settling time (dew point dependant)
Power supply	
	85 to 264 V AC, 47/440 Hz
Dew-Point Sensor	
Mirror options available	
	Gold plated copper
	Solid gold
	316 stainless steel – high temp sensor
Temperature measurement	
	4 wire Pt100, 1/3 DIN class B
Sample flow rate	
	0.1 to 2 l/min in sampling block
Max velocity	
	10 m/sec direct insertion
	30 m/sec with sintered guard
Pressure	
	2 MPa (20 barg)
	25 MPa (250 barg) optional
Ingress protection	
	IP66 (NEMA 4)
	IP65 25 MPa (250 barg) sensor (NEMA 12)
Cable length	
	2m (Maximum 30m)
Remote PRT	
Temperature measurement	
	4 wire Pt100, 1/10 DIN class B
Cable length	
	2m (Maximum 30m)
Transmitter Electronics	
Resolution	
	0.1 for °C, °F and %RH
	0.01 for g/m ³ and g/kg
Outputs	
Analog	Two channels 0/4-20 mA
Digital	RS232 (RS485 optional)
Alarm	Volt free contact, 2A @ 30 V DC
Status LEDs	
	Power on, DCC and alarm status
Operating temperature	
	-20 to +50°C ambient
Enclosure	
	Standing case with carry handle. Panel mounting kit optional
Ingress protection	
	IP54 (NEMA 2)
Cable pack	
	Power and RS232 cables

Dimensions

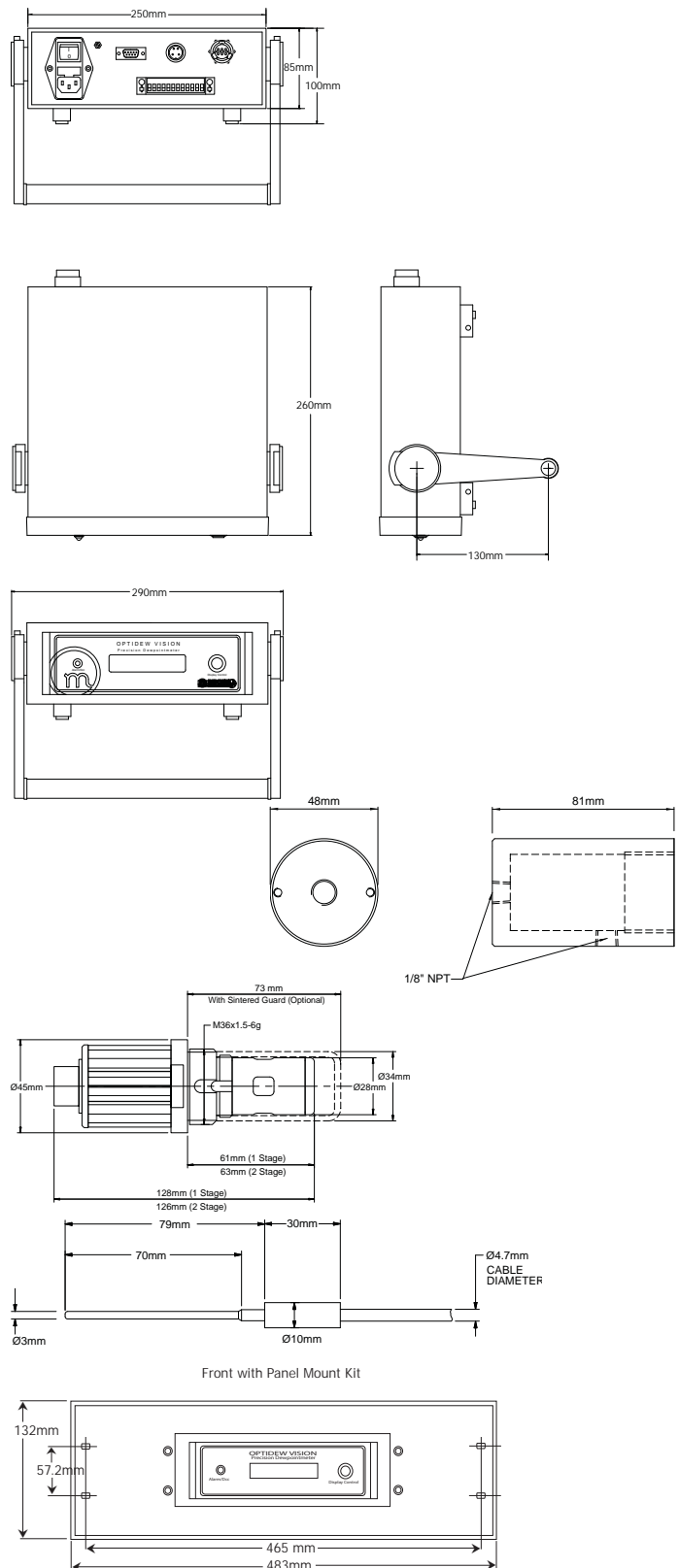

Michell Instruments Ltd 48 Lancaster Way Business Park, Ely, Cambridgeshire, CB6 3NW
 Tel: +44 (0) 1353 658000, Fax: +44 (0) 1353 658199, Email: uk.info@michell.com, Web: www.michell.com/uk

Michell Instruments adopts a continuous development programme which sometimes necessitates specification changes without notice.
 Issue no: Optidew Vision_97144_V4.1_UK_0812