

# S8000 Remote

## High Precision Chilled Mirror Hygrometer

A hygrometer offering a combination of a market-leading  $\pm 0.1^\circ\text{C}$  accuracy with the flexibility of a remote sensor, allowing straightforward installation and precision monitoring of environmental moisture.

This highly sensitive, adaptable instrument can provide extremely accurate measurements in-situ in the area of interest, or in an industrial process.



### Highlights

- Fundamental, accurate and drift-free measurement
- Remote sensor
- Open design allows remote sensor to be mounted into a sample flow or simply placed in an environment to be monitored
- $-40$  to  $+90^\circ\text{C}$  dew-point range with  $0.1^\circ\text{C}$  accuracy
- Data logging to USB or SD card
- 'FAST' guarantees frost formation below  $0^\circ\text{C}$
- Sensor operates in pressures up to 20 barg

### Applications

- Engine test cell monitoring – from commercial vehicle to high performance engines
- Environmental chamber verification for:
  - Component testing
  - Corrosion testing
  - Pharmaceutical validation
- Precision HVAC control
- Lithium Ion battery manufacture
- ... and many more

# S8000 Remote Precision Optical Dew-point Hygrometer

## Setting the Standard

The S8000 Remote chilled-mirror sensor directly measures the formation of condensation, giving long-term and unmatched, drift-free readings of dew-point and relative humidity. It offers a wide measurement range from the equivalent of <math><0.5</math> to 100% RH at temperatures up to +90°C. The instrument provides three user-configurable analog outputs and MODBUS RTU communications, allowing the instrument to be monitored by a suitable computer or PLC system or via specific S8000 Remote logging software. A pair of adjustable isolated alarm contacts allows the S8000 Remote to be used for direct process control. A high-contrast LCD display provides entirely customizable local indication of the measured values, along with a trend graph and fault warnings.



## Precision Measurements

New sensor design incorporates a high precision 1/10DIN Pt100 to provide  $\pm 0.1^\circ\text{C}$  accuracy of dew-point measurement. Combined with the  $\pm 0.1^\circ\text{C}$  accuracy temperature measurement sensor, the RH measurement accuracy of the S8000 Remote is better than other products currently available on the market.

To further improve the accuracy of pressure-derived calculated values an optional external pressure transducer can be supplied, which provides a real-time pressure input for these parameters. This allows for continued measurement stability even during sample pressure fluctuations.

## Flexibility of Use & Simplicity of Installation

The remote sensor design eliminates the potential problems usually associated with building sampling systems. The open cell sensor can now be placed directly into the environment to be monitored and does not always need a complex and expensive sampling arrangement or pump to convey the gas to be measured to the instrument.

For more challenging applications, where direct insertion is not possible, the sensor can be mounted in a sample block and included in a sampling system. This means that the product can be used for a wide range of applications, and with trace heating - including those up to dew-point temperatures of +90°C.



Application: Climatic chamber monitoring

## Technology: Chilled Mirror

Michell's chilled mirror dew-point hygrometers are precision instruments for critical measurement and control applications. Chilled mirror sensors measure a primary characteristic of moisture – the temperature at which condensation forms on a surface. This means that chilled mirror instruments:

- have no drift: the temperature at which condensation forms is measured directly so there are no calculated variables that could shift over time
- are inherently repeatable, giving reliable results every time.

The sensor operates as follows: a miniature mirror is cooled by a solid state Peltier thermoelectric heat pump until it reaches the dew point of the gas under test. When this temperature has been reached, condensation will begin to form on the mirror surface. An electro-optical loop detects that condensation is forming, by a reduction in the intensity of light reflected from the mirror surface and through the control electronics of the chilled mirror instrument. This modulates the cooling power applied to the Peltier.

The mirror surface is then controlled in an equilibrium state whereby evaporation and condensation are occurring at the same rate. In this condition the temperature of the mirror (measured by a platinum resistance thermometer) is equal to the dew-point temperature of the gas.

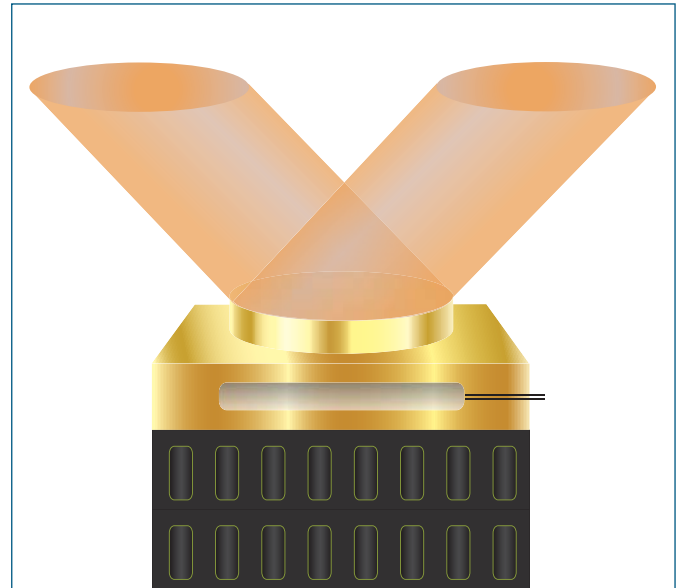

# Technical Specifications

Performance	
Measurement range	-40 to +90°C dew point
Units	°C and °F for dew point and temperature %rh, g/m <sup>3</sup> , g/kg, ppm <sub>v</sub> , ppm <sub>w</sub> (SF <sub>6</sub> ), for calculated humidities
Resolution	0.01°C
Accuracy	±0.1°C for dew point and temperature
Measurement Response Speed	1°C/sec
Repeatability	±0.05°C
Remote Temperature Probe	4-wire Pt100 ambient temperature measurement
Remote Pressure Transducer Range	0-25 bara
Remote Pressure Transducer Accuracy	0.25% FS
Electrical Output/Input	
Outputs	3 analog outputs User-definable for hygrometric units and flexible configuration for 0-20 mA, 4-20 mA or 0 to 1 V
Process Alarm	Form C relay contacts (30 V, 1 A) for hygrometric units and set-points, with user-configurable set-points
Fault Alarm	Form C relay contacts (30 V, 1 A) for mirror contamination, optical and temperature measurement fault Pre-set

Communications	MODBUS RTU protocol @ 9600 baud rate data using USB interface
Power Supply	85 V to 246 V AC, 47 to 63 Hz
Power Consumption	100W
Operating Conditions	
Sensor Pressure	0 - 20 barg
Sample Flow Rate	0.1 to 2.0 NI/min
Sensor Operating Temperature Range	-10 to +90°C
Storage Temperature	-10 to +60°C
Mechanical Specifications	
User Interface	High definition, blue LCD. User-adjustable contrast Menu navigation via five button keypad
Dimensions (Instrument)	180 x 400 x 320 mm (h x w x d)
Dimensions (Sensor)	Ø45mm x 128mm with M36 x 1.5-6g mounting thread
Cable Lengths	2, 5 or 10m
Weight	7.9 kg
General	
Data Logging	SD Card (512mb supplied) and USB interface. SD Card (FAT-16) - 2Gb max. that allows 24 million logs or 560 days, logging at 2 second intervals
Calibration	4-point traceable in-house calibration as standard UKAS accredited calibrations optional – please consult factory

## Dimensions

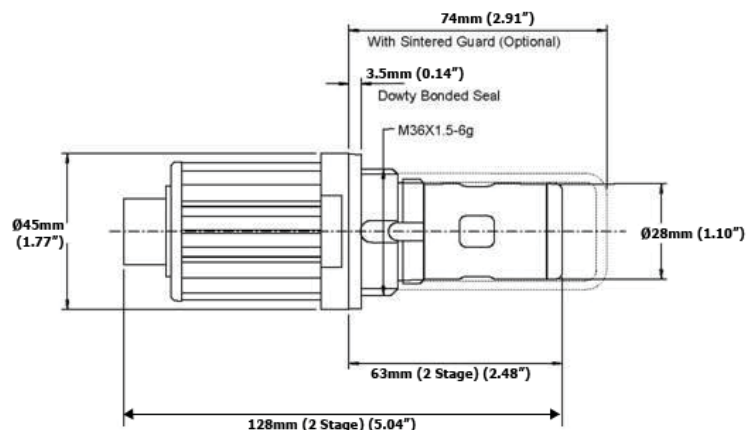
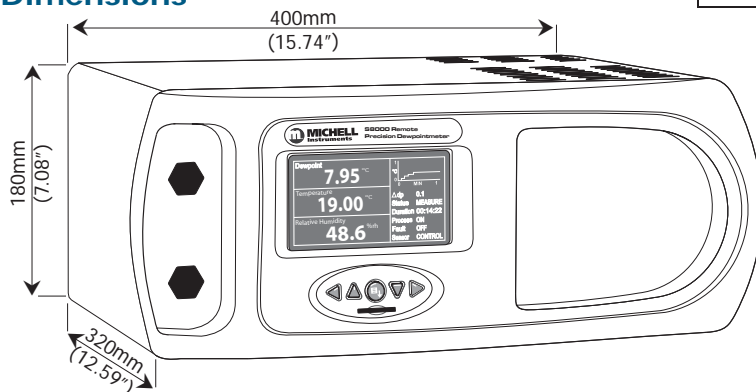

Michell Instruments 48 Lancaster Way Business Park, Ely, Cambridgeshire, CB6 3NW  
Tel: +44 1353 658000, Fax: +44 1353 658199, Email: [info@michell.com](mailto:info@michell.com), Web: [www.michell.com/uk](http://www.michell.com/uk)

Michell Instruments adopts a continuous development programme which sometimes necessitates specification changes without notice.  
Issue no: S8000 remote\_97307\_V2\_UK\_0312