

GENERAL CATALOGUE

BOX SERIES WORM GEAR UNITS

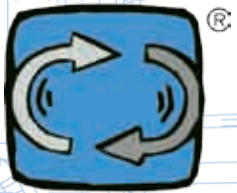

motive

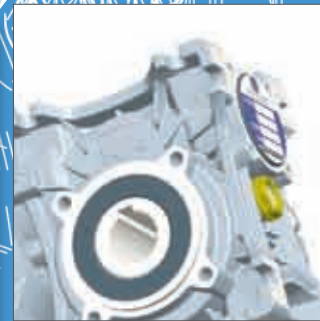
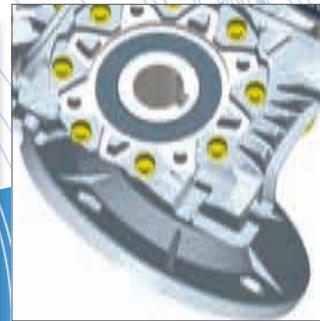
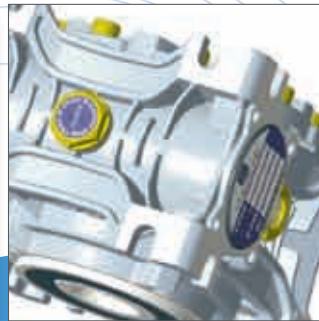
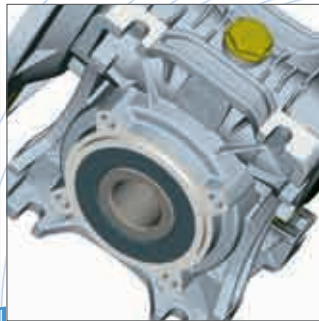
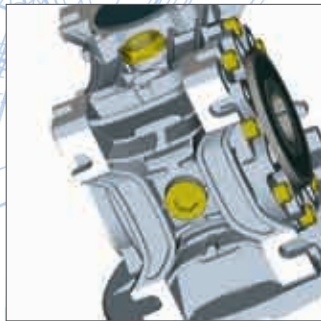
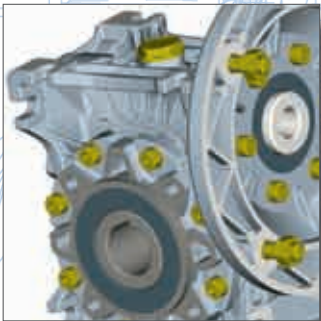

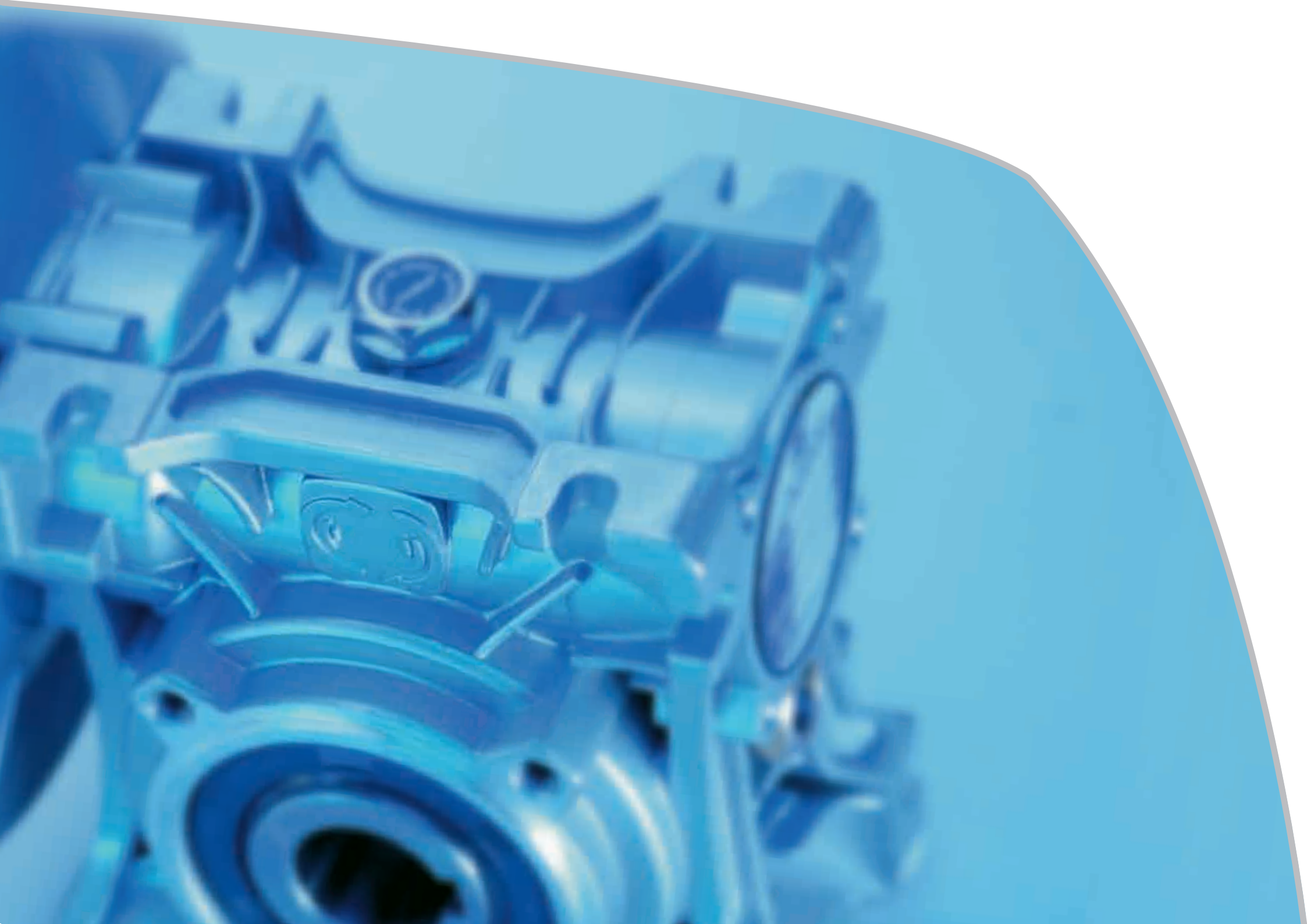

Technical characteristics pag. 2-3

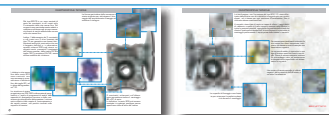

Efficiency - Irreversibility pag. 4

Mesh data pag. 5



Lubrication
Mounting Position pag. 6

Technical data pag. 7

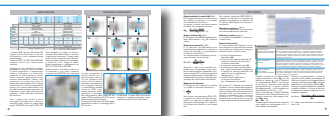

Performance tables pag. 8-9

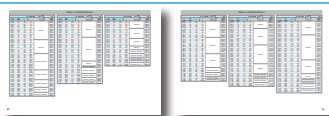

Performance tables pag. 10-11

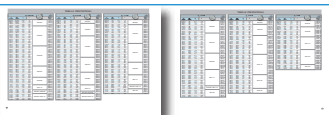

Performance tables pag. 12

Dimensional tables pag. 13



General data pag. 14

Input and combinations pag. 15



Output flange pag. 16

Accessories pag. 17



Components list pag. 18

Oil seal rings and bearings list pag. 19



Terms of sale and guarantee pag. 20



TECHNICAL CHARACTERISTICS

From type 75 and up, 2 taper roller bearings are mounted on the wormshaft, improving the mechanical resistance to the axial loads given by the wormwheel.

Moreover, the combination of this characteristic and 2 nilos (mounted on size 75 and up to keep lubrication grease inside the bearings even when they are not touched by the oil bath), or, in alternative, special RS shields on such taper bearings, permits the mounting of the whole BOX range, from the size 25 to the size 150, in the positions V5 and V6 without any need of additional interventions.



The housing shape has been studied to optimize the water draining during washing.



The new patented "BOX" series of worm gear units is made with die-casting aluminium housing from size 25 up to 90, and in cast iron from size 110.

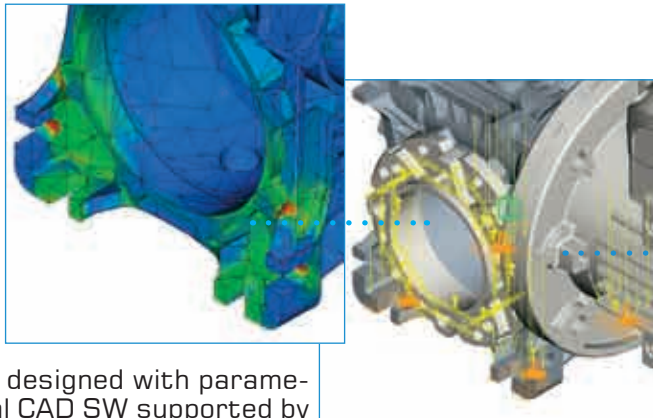

The housing has been designed with parametric three-dimensional CAD SW supported by programs of analysis of the thermal dissipation capacity and the structural resistance/deformation under the effect of working loads.

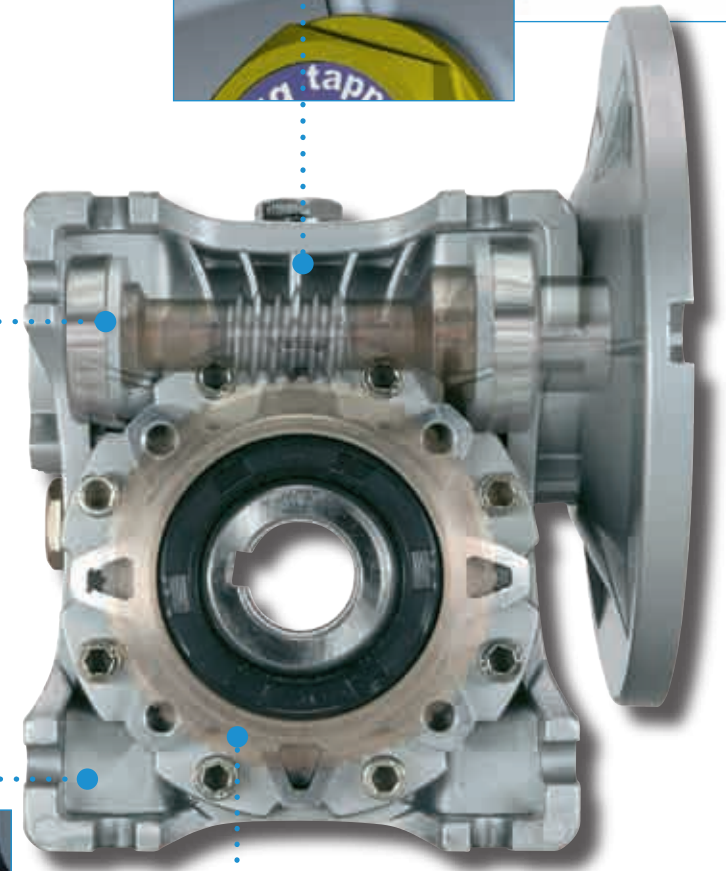
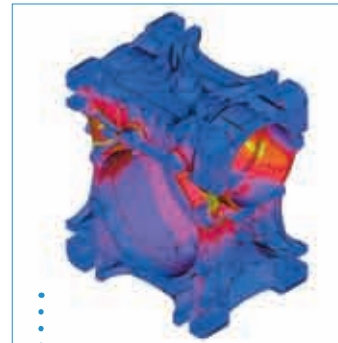

Mounting positions B6 or B7 are also permitted on all the BOX series, thanks to the adoption of 2RS auto-lubricated bearings on the output gear. In conclusion, the whole BOX series can be mounted in any position with no need of specifications in the order.

TECHNICAL CHARACTERISTICS

PATENTED

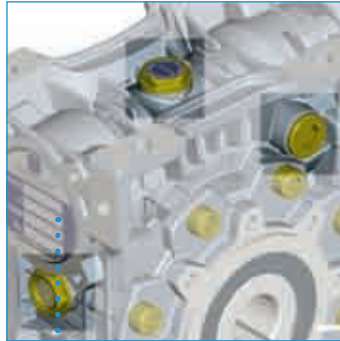

Lubrication is already provided by motive with long-life synthetic oil up to size BOX90, and with mineral oil from size BOX110.

The gear unit is equipped with a full set of filler, level and breather plugs, permitting all mounting positions and facilitating the management of the stock.

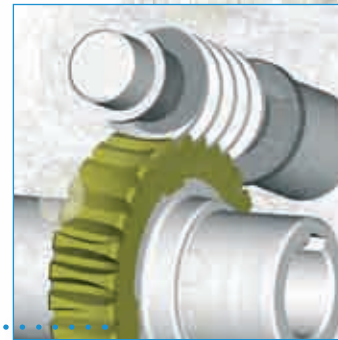

In order to increase silence, efficiency and duration, the wormshaft is made in case hardened steel and ground machined, while the worm wheel is in shell cast ZCuSn12 bronze.

Before being assembled, the worm wheel is submitted to a running-in working period to improve the surface finishing and hardness.

An epoxy paint coat cancels the negative effects of the aluminium porosity and protects the housing from oxidation.

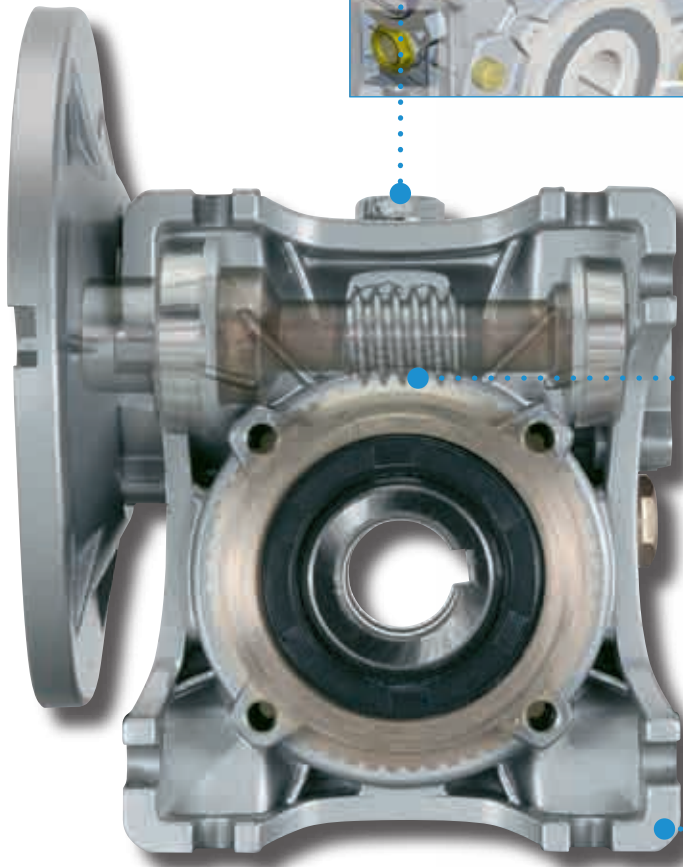

Mating surfaces are machined for a perfect planarity.

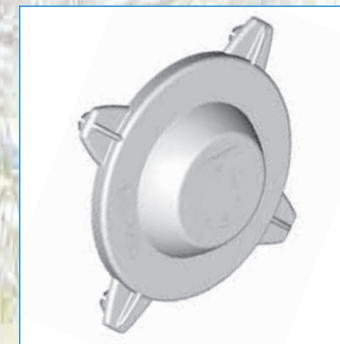

2 safety plastic covers on the output are always provided to protect BOX during transportation and storage, and then the user from accidental contacts with moving parts

EFFICIENCY

An inherent factor in the selection wormgear boxes is the efficiency η , defined as the ratio between the mechanical power coming out from the output shaft, and the power in the input shaft:

$$\eta = \frac{P_{n2}}{P_{n1}}$$

Some reasons concurring to a reduction of the efficiency can be identified in the several forms of sliding and rolling friction.

In practice, efficiency depends essentially by:

- helix angle
- material of matching parts
- tooth form accuracy
- gear finishing
- lubrication
- gear sliding speed
- load vibrations
- temperature

In the combined BOX units (BOX+BOX), the total efficiency value is the result of the product of the efficiency of the two single boxes composing the combined unit.

Dynamic efficiency η_d

It is the efficiency value that comes out after completion of the running in time of a few hours and that keeps almost constant in the subsequent time of work.

The graph 1 shows indicatively the time required to reach the maximum value of dynamic efficiency

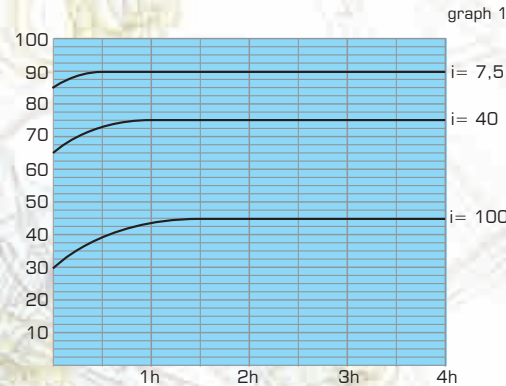

Static efficiency η_s

It is the efficiency obtained at start-up, particularly important in the choice of a BOX unit on those applications (like liftings) where due the very restricted time of work for each operation, the standard operating conditions are reached seldom. In these applications it is necessary to increase properly the motor power, in order to compensate the poor efficiency of the BOX unit while starting up ($\eta_s < \eta_d$).

IRREVERSIBILITY

Some BOX units permit to lock and hold in place a load when electric power switches off.

This characteristic, called irreversibility, is inversely proportional to the efficiency and the helix inclination, and directly proportional to the reduction ratio.

The efficiency of the toothing profiles is the main factor in effecting successfully the whole efficiency of the wormgear units, and it is on a large extent tied to the helix angle of profiles.

In order to get the fittest solution for a certain application, it is necessary to analyse the difference between static and dynamic irreversibility.

Static irreversibility

A BOX unit has a low static reversibility whenever it is possible to put it in rotation only through driving the output shaft with a very high torque and/or vibration or twisting of the output load. The static irreversibility is inversely proportional to the static efficiency. Theoretically:

$\eta_s < 50\%$	static irreversibility
$50\% < \eta_s < 55\%$	low static reversibility
$\eta_s \geq 55\%$	good static reversibility

Dynamic irreversibility

This is the most difficult condition to get. It occurs whenever, at the stop of the conditions keeping the worm shaft in rotation, even the motion of the output shaft stops immediately. The dynamic irreversibility is inversely proportional to the dynamic efficiency. Theoretically:

$\eta_d < 40\%$	total dynamic irreversibility
$40\% < \eta_d < 50\%$	good dynamic irreversibility
$50\% < \eta_d < 60\%$	low dynamic reversibility
$\eta_d \geq 60\%$	good dynamic reversibility

The table 1 proposes an indicative analysis of the different degrees of irreversibility based on the helix angle.

Note: Whenever a total irreversibility of a BOX unit is important for safety reasons, we strongly recommend the use of brake motors of the AT Delphi series.

MESH DATA

type	i	7,5	10	15	20	25	30	40	50	60	80	100
BOX 025	Z ₁	4	3	2	2	2	1	1	1	1	1	1
	Z ₂	30	30	30	40	40	30	40	50	60	80	100
	β	18° 59' 59"	15° 15' 18"	10° 18' 17"	9° 27' 44"	9° 27' 44"	5° 11' 40"	4° 45' 49"	3° 21' 59"	3° 21' 59"	3° 21' 59"	3° 21' 59"
	m _x	1,25	1,25	1,25	1	1	1,25	1	0,75	0,65	0,65	0,65
	η _d (1400)	85,90%	83,20%	78,00%	75,90%	75,90%	65,30%	62,50%	54,80%	53,80%	53,80%	53,80%
	η _s	71,75%	68,16%	60,23%	56,67%	56,67%	44,83%	41,33%	34,01%	33,26%	33,26%	33,26%
BOX 030	Z ₁	4	3	2	2	2	1	1	1	1	1	1
	Z ₂	30	30	30	40	50	30	40	50	60	80	100
	β	18° 48' 58"	14° 20' 8"	9° 40' 7"	7° 42' 13"	7° 42' 13"	5° 42' 38"	4° 52' 9"	3° 15' 37"	2° 13' 37"	2° 6' 36"	2° 6' 36"
	m _x	1,44	1,44	1,44	1,10	1,75	1,44	1,10	0,90	0,70	0,56	0,56
	η _d (1400)	82,00%	80,70%	72,60%	72,00%	68,00%	62,00%	55,00%	52,00%	46,00%	40,00%	40,00%
	η _s	65,42%	62,00%	51,86%	47,33%	39,27%	34,68%	31,74%	25,65%	25,89%	19,60%	19,60%
BOX 040	Z ₁	4	3	2	2	2	1	1	1	1	1	1
	Z ₂	30	30	30	40	50	30	40	50	60	80	100
	β	24° 28' 25"	18° 50' 51"	12° 49' 17"	10° 29' 51"	8° 45' 5"	6° 29' 31"	5° 17' 36"	4° 24' 5"	3° 47' 4"	2° 56' 9"	2° 28' 53"
	m _x	2,06	2,06	2,06	1,58	1,27	2,06	1,58	1,27	1,06	0,80	0,65
	η _d (1400)	87,30%	85,30%	81,00%	78,00%	75,00%	69,70%	65,00%	62,00%	56,00%	50,00%	0,485%
	η _s	71,24%	67,24%	59,27%	53,87%	50,18%	44,81%	38,77%	35,07%	29,90%	25,95%	24,77%
BOX 050	Z ₁	4	3	2	2	2	1	1	1	1	1	1
	Z ₂	30	30	30	40	50	30	40	50	60	80	100
	β	23° 57' 45"	18° 26' 6"	12° 31' 43"	10° 18' 17"	8° 35' 51"	6° 20' 25"	5° 11' 40"	4° 24' 5"	3° 41' 53"	2° 51' 45"	2° 17' 26"
	m _x	2,50	2,50	2,50	2,00	1,59	2,50	2,00	1,59	1,33	1,00	0,80
	η _d (1400)	89,00%	87,50%	81,80%	80,20%	75,20%	70,60%	68,30%	61,30%	57,90%	52,80%	46,00%
	η _s	70,80%	67,15%	58,86%	55,84%	50,46%	43,14%	39,76%	34,06%	31,40%	26,90%	21,12%
BOX 063	Z ₁	4	3	2	2	2	1	1	1	1	1	1
	Z ₂	30	30	30	40	50	30	40	50	60	80	100
	β	25° 50' 36"	19° 57' 51"	13° 36' 49"	10° 53' 8"	8° 44' 46"	6° 30' 20"	5° 29' 32"	4° 23' 55"	3° 56' 43"	3° 5' 17"	2° 26' 1"
	m _x	3,25	3,25	3,25	2,50	2,00	3,25	2,50	2,00	1,68	1,27	1,02
	η _d (1400)	89,10%	88,60%	82,40%	81,80%	79,70%	73,00%	70,60%	67,50%	64,50%	57,90%	51,10%
	η _s	71,89%	68,23%	59,57%	55,54%	52,11%	43,97%	40,34%	36,82%	34,33%	28,44%	4,05%
BOX 075	Z ₁	4	3	2	2	2	1	1	1	1	1	1
	Z ₂	30	30	30	40	50	30	40	50	60	80	100
	β	26° 38' 16"	20° 36' 57"	14° 4' 5"	11° 18' 36"	10° 18' 18"	7° 8' 51"	5° 42' 38"	5° 11' 40"	4° 20' 31"	3° 24' 42"	2° 51' 45"
	m _x	3,95	3,95	3,95	3,00	2,50	3,95	3,00	2,50	2,05	1,55	1,25
	η _d (1400)	91,00%	89,60%	85,20%	83,50%	81,90%	75,80%	73,80%	70,70%	65,50%	59,00%	6,50%
	η _s	72,60%	69,24%	61,14%	58,04%	54,26%	45,88%	43,05%	38,94%	35,27%	28,52%	6,71%
BOX 090	Z ₁	4	3	2	2	2	1	1	1	1	1	1
	Z ₂	30	30	30	40	50	30	40	50	60	80	100
	β	29° 11' 11"	22° 43' 48"	15° 36' 15"	13° 1' 15"	11° 18' 36"	7° 56' 58"	6° 35' 44"	5° 42' 38"	4° 45' 49"	3° 52' 55"	3° 7' 20"
	m _x	4,84	4,84	4,84	3,70	3,00	4,84	3,70	3,00	2,50	1,90	1,50
	η _d (1400)	91,30%	89,90%	88,20%	84,10%	83,50%	80,80%	74,00%	73,10%	69,60%	61,40%	59,00%
	η _s	74,05%	70,71%	65,64%	60,07%	57,02%	50,76%	44,40%	41,63%	38,33%	31,19%	28,00%
BOX 110	Z ₁	4	3	2	2	2	1	1	1	1	1	1
	Z ₂	30	30	30	40	50	30	40	50	60	80	100
	β	28° 14' 32"	21° 56' 32"	15° 1' 59"	14° 48' 14"	12° 59' 41"	7° 38' 54"	7° 31' 39"	6° 34' 55"	5° 48' 8"	4° 27' 28"	3° 52' 55"
	m _x	5,875	5,875	5,875	4,625	3,75	5,875	4,625	3,75	3,15	2,37	1,9
	η _d (1400)	92,40%	91,20%	88,40%	86,10%	83,80%	81,00%	77,20%	73,50%	72,00%	66,00%	63,00%
	η _s	73,92%	70,71%	64,76%	62,80%	58,86%	49,22%	47,51%	43,12%	40,20%	34,93%	31,80%
BOX 130	Z ₁	4	3	2	2	2	1	1	1	1	1	1
	Z ₂	30	30	30	40	50	30	40	50	60	80	100
	β	29° 14' 56"	22° 46' 57"	15° 38' 32"	13° 47' 27"	11° 53' 34"	7° 58' 11"	6° 59' 48"	6° 0' 40"	5° 16' 6"	4° 23' 55"	3° 34' 35"
	m _x	7	7	7	5,4	4,37	7	5,4	4,37	3,67	2,75	2,75
	η _d (1400)	90,00%	86,00%	84,00%	83,00%	81,00%	79,00%	75,00%	72,00%	70,00%	65,00%	62,00%
	η _s	72,00%	66,67%	61,53%	60,54%	56,89%	48,00%	46,15%	42,24%	39,09%	34,40%	31,29%
BOX 150	Z ₁	6	4	3	2	2	2	1	1	1	1	1
	Z ₂	30	30	30	40	50	30	40	50	60	80	100
	β	32° 54' 19"	25° 29' 51"	17° 55' 41"	13° 24' 45"	11° 18' 36"	9° 55' 34"	6° 47' 58"	5° 42' 38"	5° 0' 2"	4° 9' 35"	3° 37' 43"
	m _x	5,5	6,2	5,5	6,2	5	6,2	5	4,2	4,2	3,2	2,6
	η _d (1400)	90,00%	86,00%	84,00%	83,00%	81,00%	79,00%	75,00%	72,00%	70,00%	65,00%	62,00%
	η _s	72,00%	66,67%	61,53%	60,54%	56,89%	48,00%	46,15%	42,24%	39,09%	34,40%	31,29%

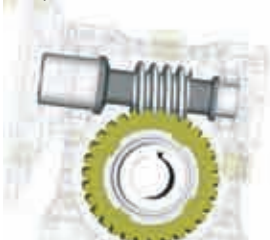

- Z₁ nr of starts of the worm
- Z₂ nr of wormwheel teeth = Z₁ · i
- β helix angle
- m_x normal module
- η_d(1400) dynamic efficiency with n₁ = 1400rpm
- η_s static efficiency

tab. 1

β	irreversibility	
	dynamic	static
β > 20°	total reversibility	
10° < β < 20°	high dynamic reversibility	almost total reversibility, quick return
8° < β < 10°	high dynamic reversibility, low irreversibility	quick return
5° < β < 8°	low dynamic reversibility, but easy in case of vibrations	good reversibility and poor self-locking
3° < β < 5°	low dynamic reversibility, good irreversibility	very low reversibility and good irreversibility
1° < β < 3°	total irreversibility	

LUBRICATION

tab. 3

	BOX025	BOX030	BOX040	BOX050	BOX063	BOX075	BOX090	BOX110	BOX130	BOX150	
	synthetic oil							mineral oil			
T°C	-25°C ÷ +50°C							-5°C ÷ +40°C			
ISO VG...	ISO VG320							ISO VG460			
AGIP	TELIUM VSF320							BLASIA 460			
SHELL	TIVELA OIL SC320							OMALA OIL460			
ESSO	S220							SPARTAN EP460			
MOBIL	GLYGOYLE 30							OBILGEAR 634			
CASTROL	ALPHASYN PG320							ALPHA MAX 460			
BP	ENERGOL SG-XP320							ENERGOL GR-XP460			
oil quantity (lt)	B3,V5	0,02	0,04	0,08	0,15	0,30	0,55	1,00	3	4,5	7
	B6,B7 B8,V6								2,2	3,3	5,1
maintenance	pre-lubricated by Motive							pre-lubricated with oil for B3 position			
	none, lifetime lubrication							oil change after 400 working hours, than every 4000 working hours			

Unless otherwise specified, BOX units sizes 25 up to 90 are supplied with long-life lubrication and they don't require any maintenance. BOX110, BOX130 and BOX150 are already pre-lubricated as well, with mineral oil VG460.

The use of oil instead of grease offers remarkable improvements under the point of view of the application, especially in the effectiveness and efficiency of the lubrication in the "limit layer" condition as well as under high intermittence applications.

Furthermore, synthetic oil lubrication assures a much wider range of low and high operating temperatures. With the use of synthetic oil, the temperature limits turn out to be determined by the properties of the seal material as well as the thermal expansion of the frame material.

All units are supplied with plugs for loading, discharging and checking the level of the oil. Furthermore, the units BOX063, BOX075, BOX090, BOX110,

BOX130 and BOX150 are accompanied by a breather plug. Before start-up, we suggest to re-place the filler plug in the upper side of the unit with the breather plug. This operation is compulsory on BOX110, 130 and 150.

The combination on the input shaft of 2 taper roller bearings (mounted on size 75 and up to get an high resistance to the axial loads) and 2 nilos (mounted

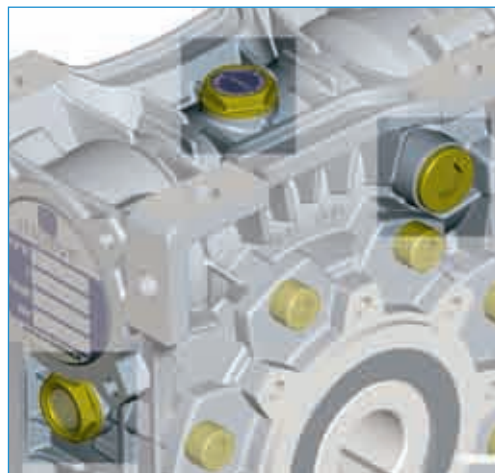

MOUNTING POSITIONS

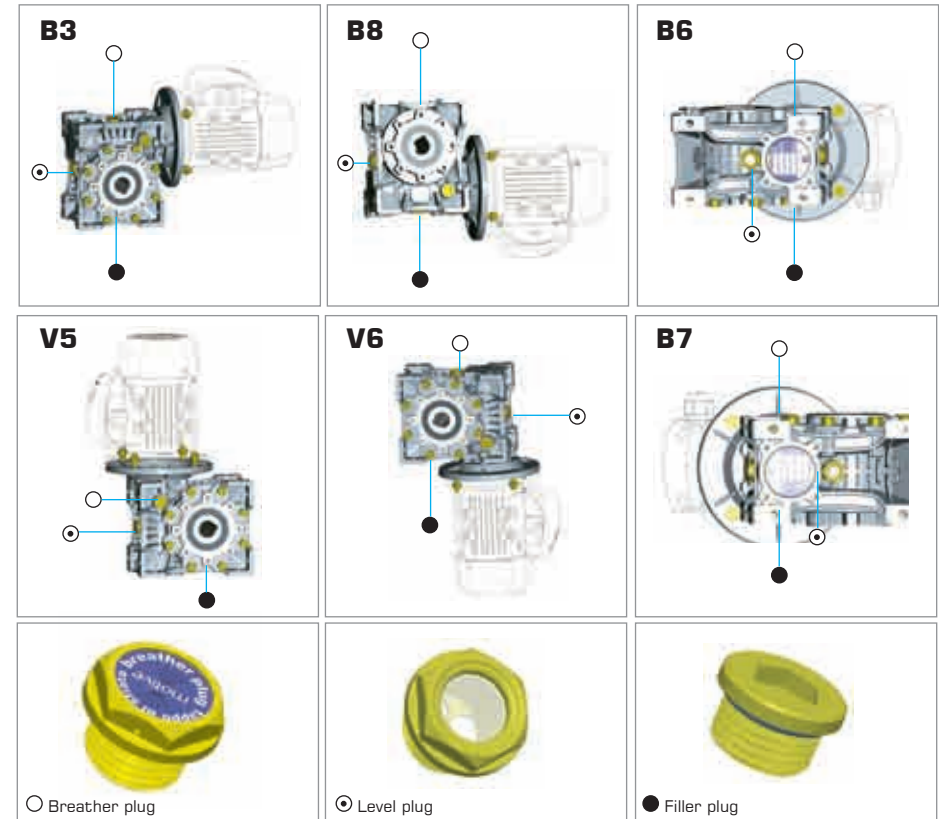

on the unit sizes 75 up to 150 to keep lubricating grease inside the bearings even when they are not touched by the lubrication oil) or, in alternative, special RS shields on such taper bearings, permits the mounting of the whole BOX range, from the size 25 to the size 150, in the positions V5 and V6.

Mounting positions B6 or B7 are also permitted on all the BOX series, thanks to the adoption of 2RS auto-lubricated bearings on the output shaft.



In conclusion, the whole BOX series can be mounted in any position with no need of specifications in the order.

Rated output torque M_{n2} [Nm]

Torque output transmissible under uniform loading and referred to the input speed n_1 and the corresponding output speed n_2 .

The output torque can be calculated with the following formula:

$$M_{n2} = \frac{P_{n1} [kW] \cdot 9550}{n_2} \cdot \eta_d$$

Torque demand M_{r2} [Nm]

Torque calculated based on application requirements. It must be $\leq M_{n2}$ of the chosen BOX unit.

Input power P_{n1} [kW]

This is the power value of the motor applied to the input shaft and corresponding to a certain input speed n_1 , a service factor $f_s=1$ and a duty service S_1 .

It is even possible to calculate the motorsize necessary by using the formula:

$$P_{n1} [kW] = \frac{M_{r2} \cdot n_2}{9550 \cdot \eta_d}$$

Since the value calculated in this way could not really correspond to an input power actually available in the IEC standardised motors, it will be necessary to choose, among the input powers available, the one which is immediately higher, checking this in the Motive catalogue of the motors.

Gear ratio i

It is the relationship of the input speed n_1 and the output speed n_2

$$i = \frac{n_1}{n_2}$$

In the BOX units with pre-stage reduction (BOX+PC), the total ratio is given

by the PC pre-stage reduction ratio multiplied by the BOX unit ratio.

In the combined BOX units (BOX+BOX), the total ratio is the result of the product of the ratio of the two single boxes composing the combined unit.

Input speed n_1 [rpm]

It is the speed the BOX unit is driven at.

Output speed n_2 [rpm]

It is the rotation speed of the output shaft.

Service factor f_s

It is a numeric value describing the BOX unit service duty. With unavoidable approximation, it takes into consideration:

- the daily working hours **h/d**
- the load classification (see table 2), and then the moment of inertia of the driven masses.
- The number of starts per hour **s/h**
- The presence of brake motors, for which it is necessary to multiply for 1.12 the service factor value deducted by the graph 2.
- The significance of the application in terms of safety, for example lifting of parts

In the graph 2, the service factor f_{sr} required by a certain application can be attained, after having selected the proper "daily working hours" (h/d) column, by intersecting the number of starts per hour (s/h) and one of the a, b or c curves. The curves a, b and c are linked with the load classification described in the table 2.

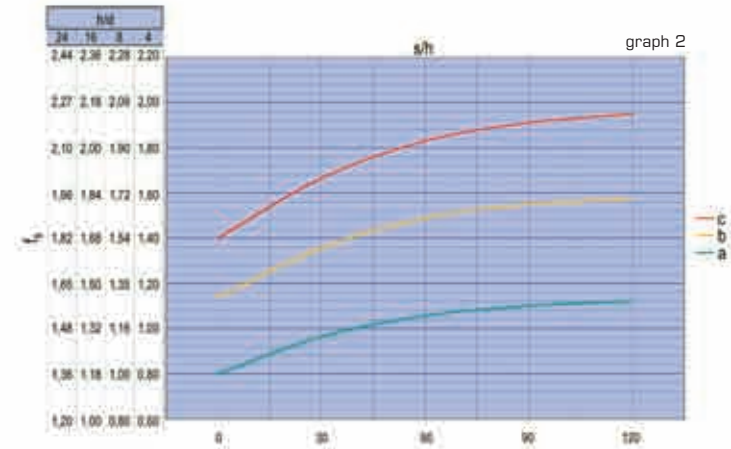

tab. 2

load classification	application
c uneven operation, heavy loads, larger masses to be accelerated	conveyors with violent jerks; compressors ad alternate pumps with 1 or more cylinders; machinery for bricks, tiles and clay; kneaders; milling machines; lifting winches with buckets; rotting furnaces; heavy fans or mining purposes; mixers for heavy materials; machine-tools; planing kinds; alternating saws; shears; tumbling barrels; vibrators; shredders; turntables
b starting with moderate loads, uneven operating conditions, medium size masses to be accelerated	belt conveyors with varied load with transfer of bridge trucks for light duty; levelling machines; shakers and mixed for liquid with variable density and viscosity; machines for the food industry (kneading troughs, mincing machines, slicing machines, etc); sifting machines for sand gravel; textile industry machines; cranes, hoists, goodstifts; fertilizer scrapers; concrete mixers; folding machines; winches; crane mechanisms
a easy starting, smooth operation, small masses be accelerated	belt conveyors for light material; centrifugal pumps; rotary gear pumps; screw feeders for light materials; lifts; bottling machines; auxiliary controls of tool machines; fans; power generators; fillers; small mixers



If, after the selection of the right M_{r2} and n_2 in the following performance tables, you don't find a BOX unit whose service factor f_s is \geq of the requested one f_{sr} , you can choose a BOX unit in which $M_{n2} > M_{r2}$. In fact, in order to satisfy f_{sr} , you can choose another BOX unit whose output torque is $\geq M_{c2}$ output torque, where:
 $M_{c2} = M_{r2} \cdot f_{sr}$
 Note: This rule is valid only if the new BOX unit that has been selected in this way has a service factor $f_s \geq 1$ in the performance tables.
 From another point of view, the value of f_s



in the performance tables refers to a case in which the effective torque requested by the application M_{r2} matches perfectly with the one appearing on the catalogue M_{n2} . Whenever the torque indicated in the performance table is higher than the requested one, the offered service factor of the performance table can be increased according to the formula:



$$f_{s \text{ real}} = \frac{f_s \text{ on the table} \cdot M_{n2} \text{ on the table}}{M_{r2}}$$



The value of f_s calculated in this way must be $\geq f_{sr}$.



PERFORMANCE TABLES



P ₁ 4 kW					
n ₂ [rpm]	M ₂ [Nm]	f _s	i		
373,3	93	1,4	7,5	BOX075	112M-2
280,0	123	1,2	10		112M-2
186,7	182	1,0	7,5		112M-4
140,0	240	0,8	10		112M-4
373,3	94	2,2	7,5	BOX090	112M-2
280,0	123	1,9	10		112M-2
186,7	184	1,6	7,5		112M-4
140,0	243	1,3	10		112M-4
93,3	352	1,0	15	BOX110	112M-4
70,0	458	0,8	20		112M-4
140,0	243	2,5	10		112M-4
120,0	283	2,3	7,5		132M-6
93,3	352	1,9	15	BOX130	112M-4
90,0	374	1,9	10		132M-6
70,0	464	1,4	20		112M-4
60,0	541	1,4	15		132M-6
60,0	573	1,2	25	BOX150	112M-4
46,7	647	1,1	30		112M-4
120,0	287	3,1	7,5		132M-6
90,0	374	2,6	10		132M-6
60,0	541	2,0	15	BOX130	132M-6
56,0	573	1,6	25		112M-4
46,7	655	1,6	30		112M-4
45,0	713	1,5	20		132M-6
36,0	870	1,2	25	BOX150	132M-6
35,0	851	1,2	40		112M-4
28,0	1023	1,0	50		112M-4
23,3	1179	0,8	60		112M-4
28,0	778	1,8	50	BOX150	100LB-4
23,3	896	1,4	60		100LB-4
17,5	1113	1,0	80		100LB-4
14,0	1310	0,8	100		100LB-4

P ₁ 7,5 kW					
n ₂ [rpm]	M ₂ [Nm]	f _s	i		
186,7	345	1,6	7,5	BOX110	132M-4
140,0	455	1,3	10		132M-4
93,3	660	1,0	15		132M-4
186,7	349	2,1	7,5		132M-4
140,0	455	1,8	10	BOX130	132M-4
93,3	668	1,4	15		132M-4
70,0	880	1,0	20		132M-4
56,0	1074	0,9	25		132M-4
46,7	1228	0,8	30	BOX150	132M-4
35,0	1596	0,7	40		132M-4
70,0	880	1,5	20		132M-4
56,0	1074	1,1	25		132M-4
46,7	1274	0,9	30	BOX150	132M-4
35,0	1596	1,0	40		132M-4

P ₁ 9,2 kW					
n ₂ [rpm]	M ₂ [Nm]	f _s	i		
186,7	424	1,3	7,5	BOX110	132MB-4
186,7	428	1,8	7,5		132MB-4
140,0	559	1,5	10	BOX130	132MB-4
93,3	819	1,1	15		132MB-4
70,0	1079	0,8	20		132MB-4
56,0	1318	0,7	25		132MB-4
70,0	1079	1,2	20	BOX150	132MB-4
56,0	1318	0,9	25		132MB-4
46,7	1563	0,8	30		132MB-4
35,0	1958	0,8	40		132MB-4

P ₁ 5,5 kW					
n ₂ [rpm]	M ₂ [Nm]	f _s	i		
186,7	253	2,2	7,5	BOX110	132S-4
140,0	334	1,8	10		132S-4
93,3	484	1,4	15		132S-4
70,0	638	1,0	20		132S-4
140,0	334	2,5	10	BOX130	132S-4
93,3	490	1,9	15		132S-4
70,0	645	1,4	20		132S-4
56,0	788	1,2	25		132S-4
46,7	900	1,2	30	BOX150	132S-4
35,0	1171	0,9	40		132S-4
70,0	645	2,0	20		132S-4
56,0	788	1,5	25		132S-4
46,7	934	1,3	30	BOX150	132S-4
35,0	1171	1,3	40		132S-4
28,0	1426	1,0	50		132S-4
23,3	1643	0,8	60		132S-4

P ₁ 11 kW					
n ₂ [rpm]	M ₂ [Nm]	f _s	i		
186,7	424	2,3	7,5	BOX150	160M-4
140,0	675	1,8	10		160M-4
93,3	990	1,3	15		160M-4
70,0	1291	1,0	20		160M-4
56,0	1576	0,8	25	BOX150	160M-4

P ₁ 15 kW					
n ₂ [rpm]	M ₂ [Nm]	f _s	i		
186,7	698	1,7	7,5	BOX150	160L-4
140,0	921	1,3	10		160L-4
93,3	1351	0,9	15		160L-4
70,0	1760	0,7	20		160L-4

DIMENSIONAL TABLES

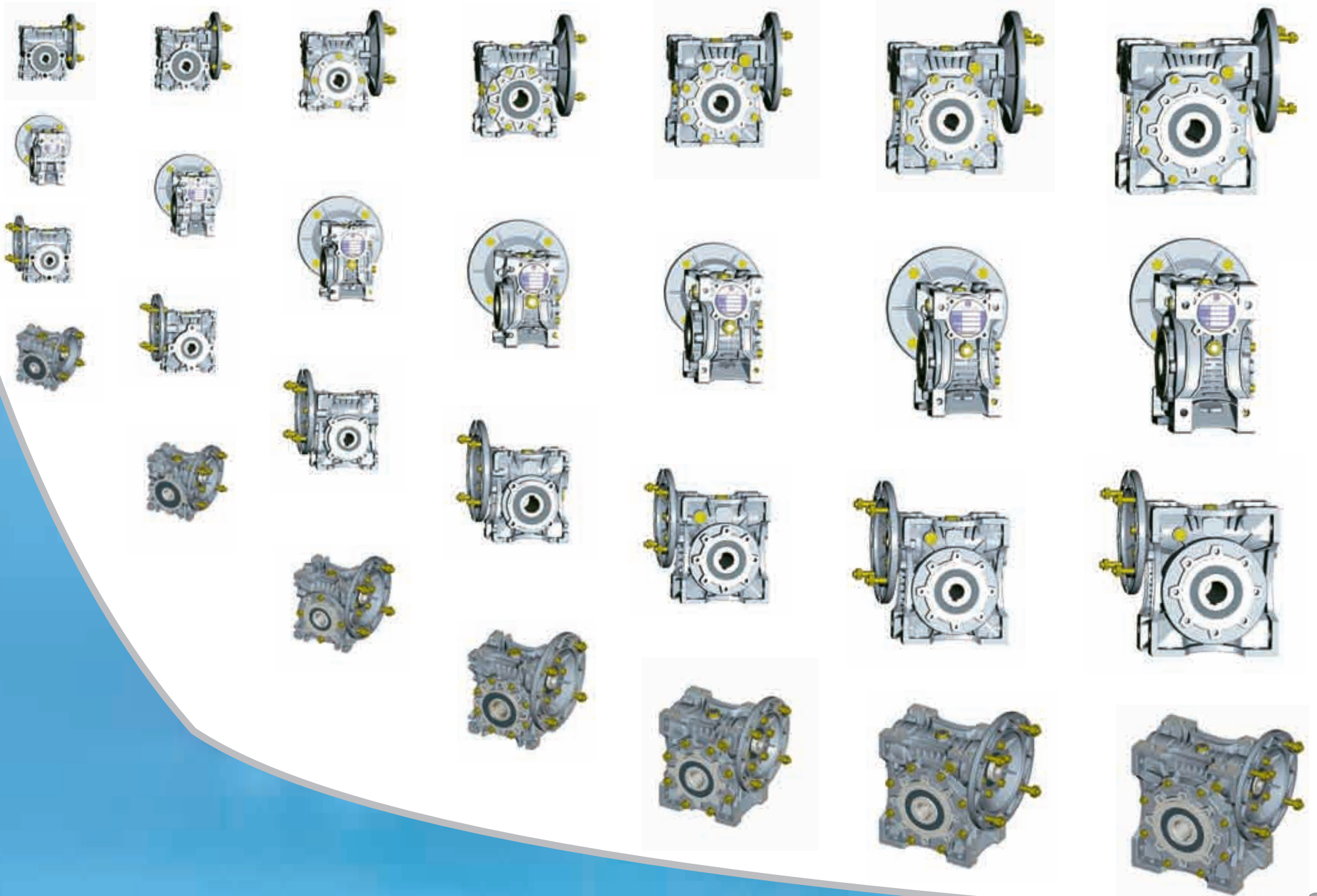

DIMENSIONAL TABLES

general data

Box type	A	C	G	H	I	K	KE	L	M	N (h8)	N1	O	P	Q	R	S	V	W	T	G1	D (h7)	output		MB/MF						Kg	
																						b	t	B	D1 (j6)	G2	G3	b1	t1		f
BOX025	45	70	45	35	25	34	M6,5 (n°3)	42	55	45 (h9)	22,5	6	-	35,5	48	5	22,5	-	16	50	11	4	12,8	-	-	-	-	-	-	-	0,7
BOX030	54	80	55	40	30	44	M6x11 (n°4)	56	65	54	29	6,5	75	44	57	5,5	27	-	20	63	14	5	16,3	20	9	51	45	3	10,5	-	1,2
BOX040	70	101	70	50	40	60	M6x10 (n°4)	71	75	60	36,5	6,5	87	55	71,5	6,5	35	45°	23	78	18 (19)	6	20,8 (21,8)	23	11	60	53	4	12,5	-	2,7
BOX050	80	121,5	80	60	50	70	M8x10 (n°4)	85	85	70	43,5	8,5	100	64	84	7	40	45°	30	92	25 (24)	8	28,3 (27,3)	30	14	74	64	5	16	M6	3,6
BOX063	100	147,5	95	72	63	85	M8x14 (n°8)	103	95	80	53	8,5	110	80	102	8	50	45°	40	112	25 (28)	8	28,3 (31,3)	40	19	90	75	6	21,5	M6	7,8
BOX075	120	174	112,5	86	75	90	M8x14 (n°8)	113	115	95	57	11	140	93	119	10	60	45°	50	120	28 (35)	8 (10)	31,3 (38,3)	50	24	105	90	8	27	M8	9
BOX090	140	208	129,5	103	90	100	M10x18 (n°8)	130	130	110	67	13	160	102	135	11	70	45°	50	140	35 (38)	10	38,3 (41,3)	50	24	125	108	8	27	M8	13
BOX110	170	252,5	160	127,5	110	115	M10x18 (n°8)	144	165	130	74	14	200	125	167,5	15	85	45°	60	155	42	12	45,3	60	28	142	135	8	31	M10	38
BOX130	200	292,5	180	147,5	130	120	M12x21 (n°8)	155	215	180	81	16	250	140	187,5	15,5	100	45°	60	170	45	14	48,8	80	30	162	155	8	33	M10	52
BOX150	240	340	210	170	150	145	M12x21 (n°8)	185	215	180	96	18	250	180	230	18	120	45°	72,5	200	50	14	53,8	80	35	195	175	10	38	M12	91

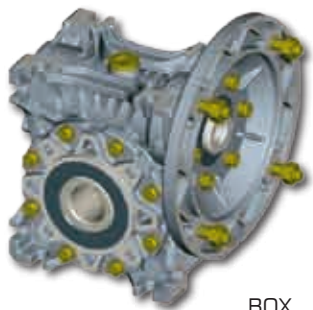
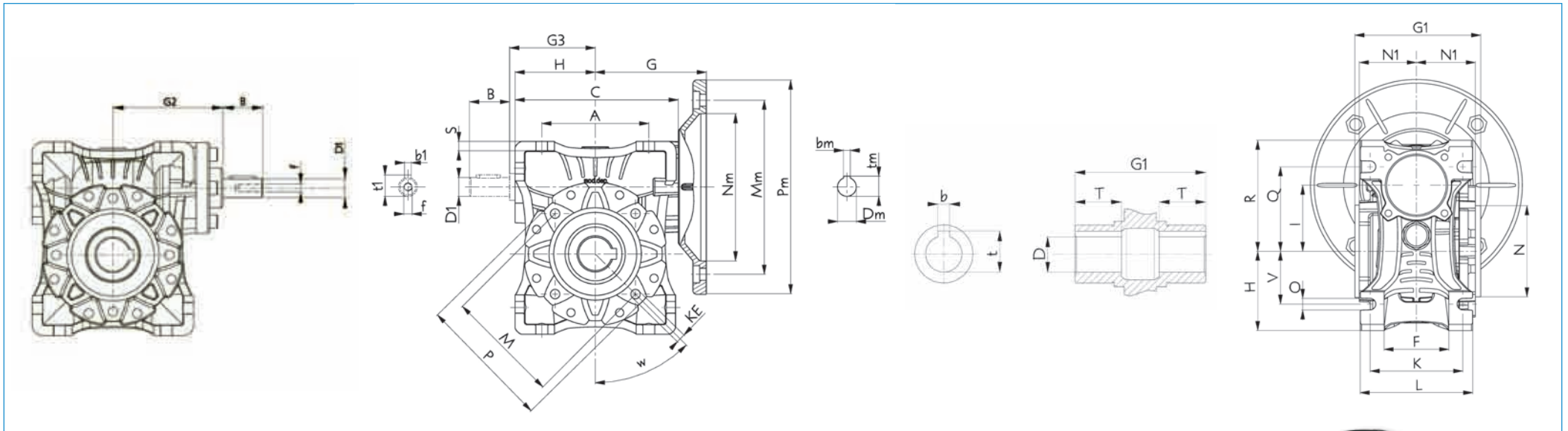

BOX



BOX + MF



BOX + MB

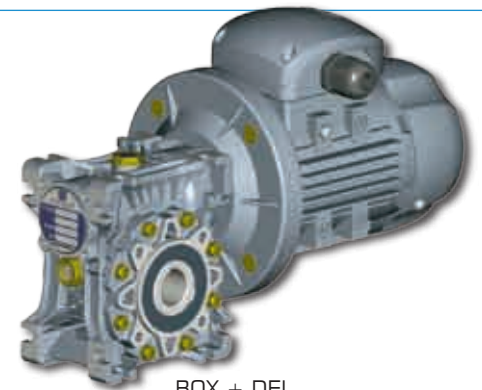

BOX + DEL

DIMENSIONAL TABLES

input and combinations

BOX type	motor type		Nm	Mm	Pm	Dm	i									
							7,5	10	15	20	25	30	40	50	60	80
BOX025	56	B14	50	65	80	9										
	56	B14	50	65	80	9										
BOX030	63	B5	95	115	140	11										
		B14	60	75	90											
BOX040	63	B5	95	115	140	11										
	71	B5	110	130	160	14										
BOX050	63	B5	95	115	140	11										
	71	B5	110	130	160	14										
	80	B5	130	165	200	19										
BOX063	71	B5	110	130	160	14										
	80	B5	130	165	200	19										
	90	B5				24										
BOX075	80	B5	130	165	200	19										
	90	B5				24										
	100/112	B5	180	215	250	28										
BOX090	80	B5	130	165	200	19										
	90	B5				24										
	100/112	B5	180	215	250	28										
BOX110	90	B5	130	165	200	24										
	100/112	B5	180	215	250	28										
	132	B5	230	265	300	38										
BOX130	90	B5	130	165	200	24										
	100/112	B5	180	215	250	28										
	132	B5	230	265	300	38										
BOX150	100/112	B5	180	215	250	28										
	132	B5	230	265	300	38										
	160	B5	250	300	350	42										

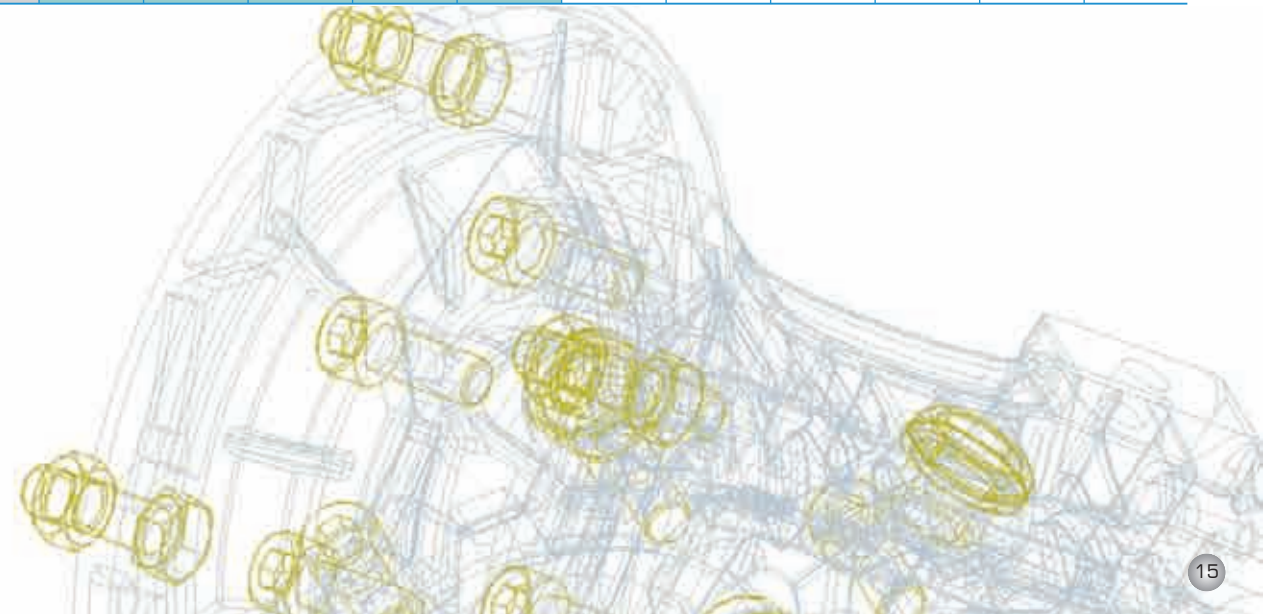
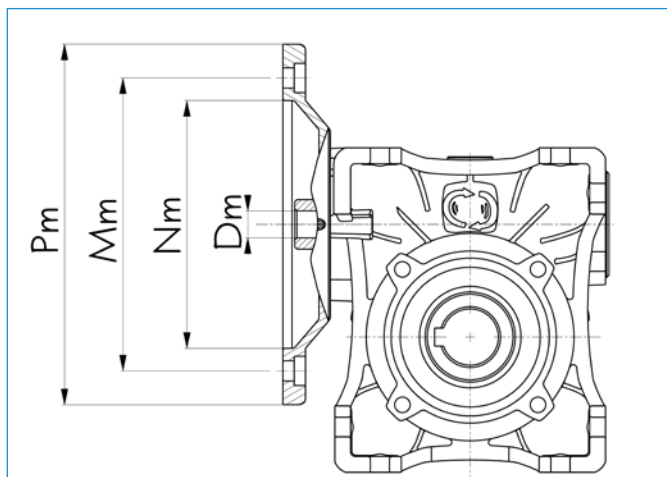

DIMENSIONAL TABLES

output flange F

output flange FL

type	output flange F									output flange FL								
	KA	KB	KC	KM	KN (h8)	KO	KP	KQ	KW	KA	KB	KC	KM	KN	KO	KP	KQ	KW
BOX025	45	6	2,5	55	40	6,5 (n°4)	75	70	45°	-	-	-	-	-	-	-	-	-
BOX030	54,5	6	4	68	50	6,5 (n°4)	80	70	45°	-	-	-	-	-	-	-	-	-
BOX040	67	7	4	75	60	9 (n°4)	110	95	45°	97	7	4	75	60	9 (n°4)	110	95	45°
BOX050	90	9	5	85	70	11 (n°4)	125	110	45°	120	9	5	85	70	11 (n°4)	125	110	45°
BOX063	82	10	6	150	115	11 (n°4)	180	142	45°	112	10	6	150	115	11 (n°4)	180	142	45°
BOX075	111	13	6	165	130	14 (n°4)	200	170	45°	-	-	-	-	-	-	-	-	-
BOX090	111	13	6	175	152	14 (n°4)	210	200	45°	-	-	-	-	-	-	-	-	-
BOX110	139	15	6	220	170	14 (n°8)	270	250	45°	-	-	-	-	-	-	-	-	-
BOX130	140	15	6	255	180	16 (n°8)	290	290	22,5°	-	-	-	-	-	-	-	-	-
BOX150	155	15	6	255	180	16 (n°8)	290	290	22,5°	-	-	-	-	-	-	-	-	-

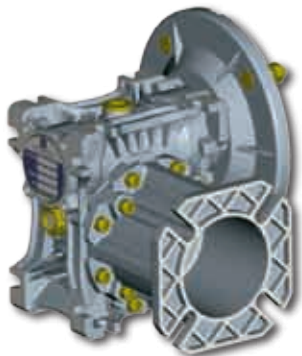

BOX + F/FL

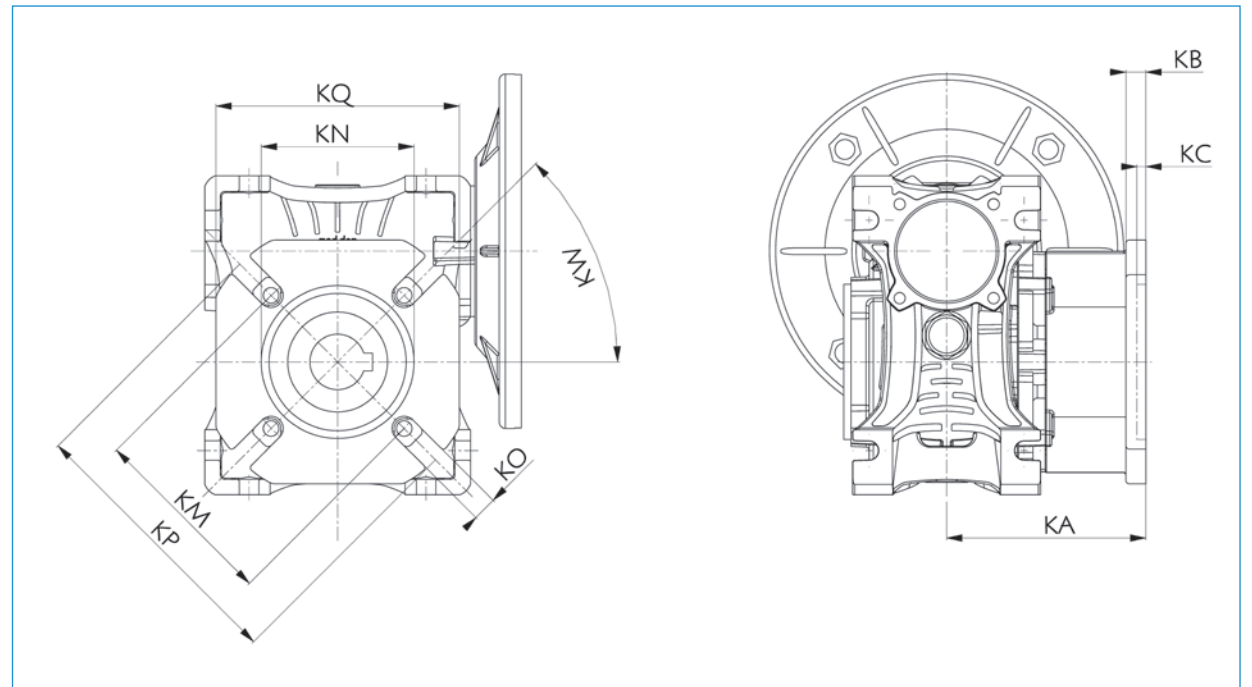

DIMENSIONAL TABLES

Accessories

Torque arm

type	K1	G	KG	KH	R
BOX025	70	14	17,5	8	15
BOX030	85	14	24	8	15
BOX040	100	14	31,5	10	18
BOX050	100	14	38,5	10	18
BOX063	150	14	49	10	18
BOX075	200	25	47,5	20	30
BOX090	200	25	57,5	20	30
BOX110	250	30	62	25	35
BOX130	250	30	69	25	35
BOX150	250	30	84	25	35

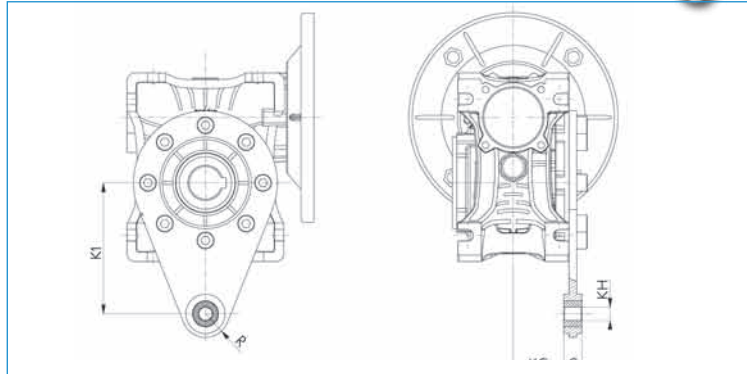
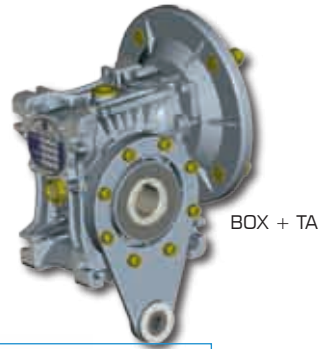

Combined

BOX + BOX	K	I1	I2	G4
BOX030+BOX040	122	30	10	201
BOX030+BOX050	132	30	20	221
BOX030+BOX063	145	30	63	246
BOX040+BOX075	167,5	40	35	290
BOX040+BOX090	184,5	40	50	324
BOX050+BOX110	226	50	60	397

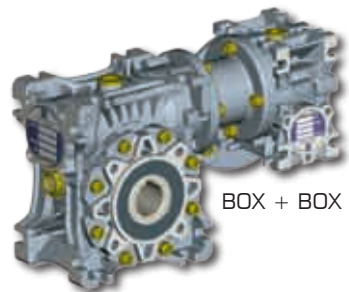
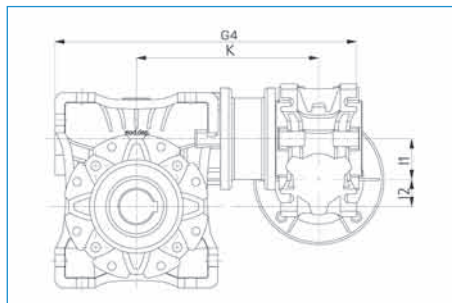

Single and double output shaft

type	d (h6)	B	B1	G1	L	L1	f	b1	t1
BOX025	11	23	25,5	50	81	101	-	4	12,5
BOX030	14	30	32,5	63	102	128	M6	5	16
BOX040	18	40	43	78	128	164	M6	6	20,5
BOX050	25	50	53,5	92	153	199	M10	8	28
BOX063	25	50	53,5	112	173	219	M10	8	28
BOX075	28	60	63,5	120	192	247	M10	8	31
BOX090	35	80	84	140	234	308	M12	10	38
BOX110	42	80	84,5	155	249	324	M16	12	45
BOX130	45	80	85	170	265	340	M16	14	48,5
BOX150	50	82	87	200	297	374	M16	14	53,5

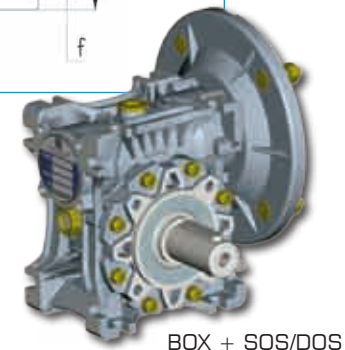
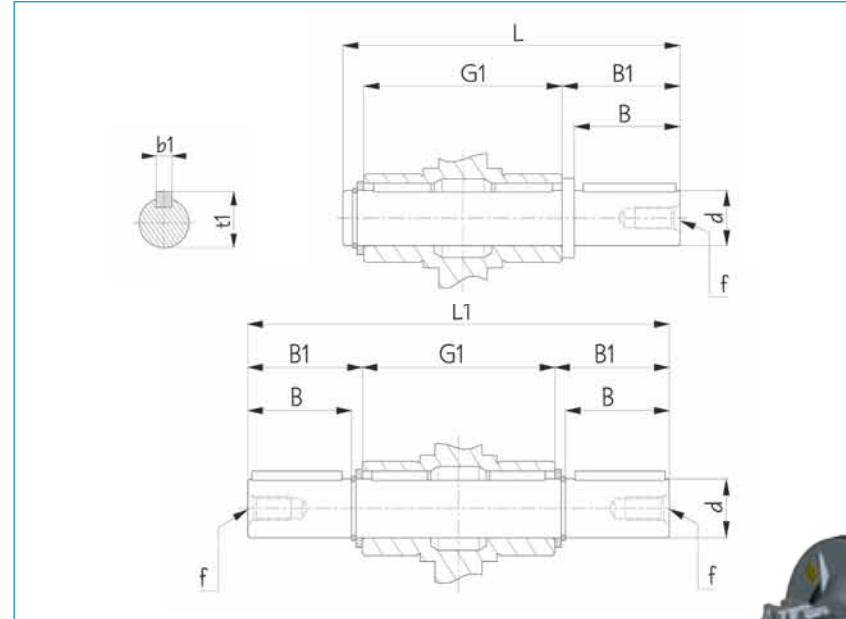

COMPONENTS LIST

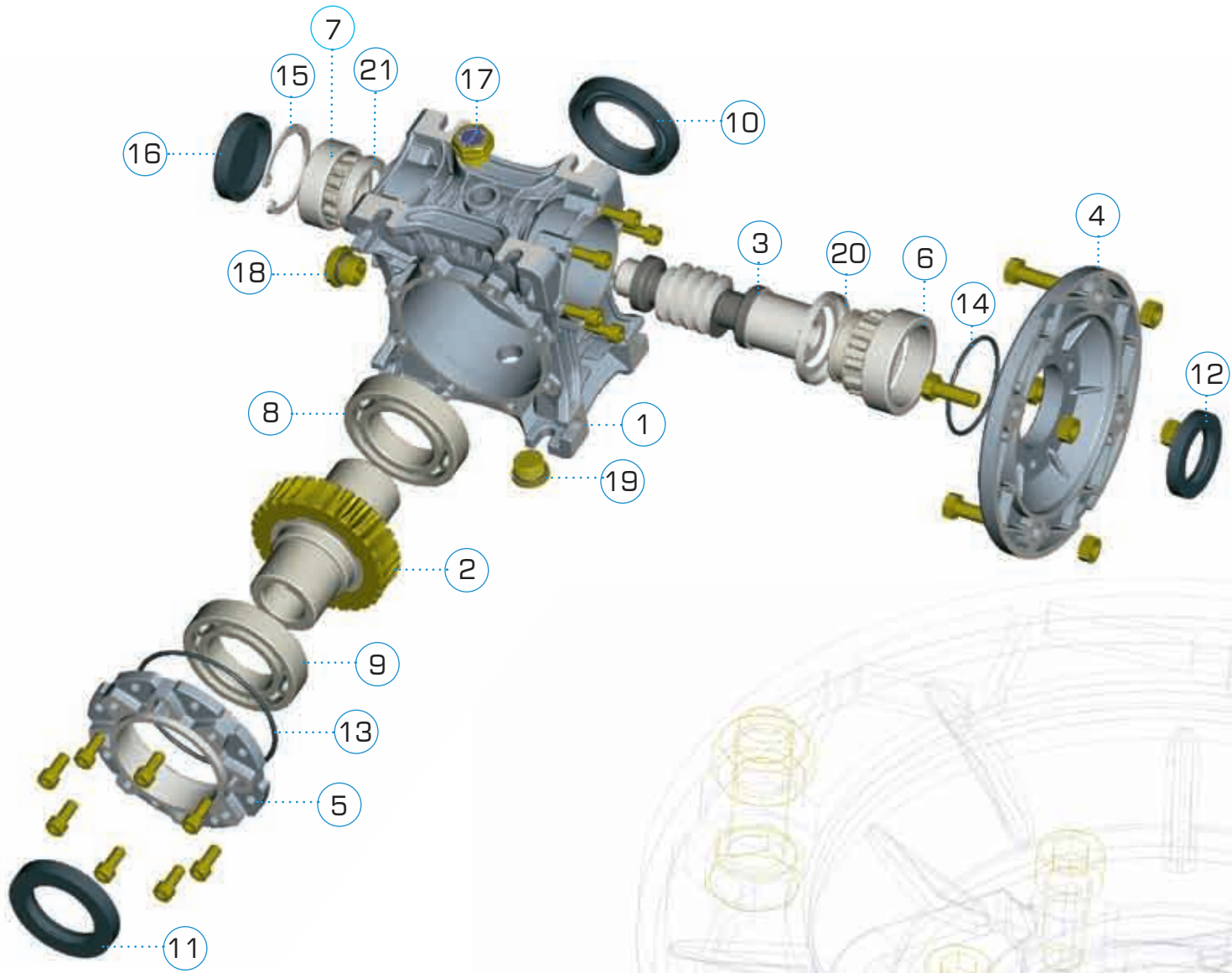

N°	CODE
1	BOXHOU
2	BOXGEA
3	BOXSHA
4	BOXFLA
5	BOXCAP
6	BOXB06
7	BOXB07
8	BOXB08
9	BOXB09
10	BOXS10
11	BOXS11
12	BOXS12
13	BOXS13
14	BOXS14
15	BOXSEE
16	BOXCOV
17	BOXBPL
18	BOXLPL
19	BOXFPL
20	BOXN20
21	BOXN21

OIL SEAL RINGS AND BEARINGS LIST

Mounting position: any

	bearings				oil seals		
	6	7	8	9	10	11	12
BOX 25	6000-2RS	61803	61904	16004	20×32×6	20×42×6	16×24×7
BOX 30	6002-2RS	61904	6005	6005	25×47×7	25×47×7	20×30×7
BOX 40	6203-2RS	6005	6006	6006	30×40×7	30×40×7	25×35×7
BOX 50	6204-2RS	6006	6008-2RS	6008-2RS	40×62×8	40×62×8	30×47×7
BOX 63	6205-2RS	6007	6009-2RS	6009-2RS	45×65×8	45×65×8	35×52×10
BOX 75	32008-RS	30206-RS	6010-2RS	6010-2RS	50×72×8	50×72×8	40×60×10
BOX 90	32008-RS	30206-RS	6012-2RS	6012-2RS	60×85×10	60×85×10	40×60×10
BOX110	32010-RS	32207-RS	6013-2RS	6013-2RS	60×85×8	60×85×8	50×68×8
BOX130	32010-RS	32207-RS	6015-2RS	6015-2RS	70×90×10	70×90×10	50×68×8
BOX150	30212-RS	30209-RS	6018-2RS	6018-2RS	90×120×12	90×120×12	60×90×10



TERMS OF SALE AND GUARANTEE

ARTICLE 1 GUARANTEE

1.1 Barring written agreements, entered into between the parties hereto each time, Motive hereby guarantees compliance with specific agreements.

The guarantee for defects shall be restricted to product defects following design, materials or manufacturing defects leading back to Motive.

The guarantee shall not include:

- * Faults or damages ensuing from transport. Faults or damages ensuing from installation defects; incompetent use of the product, or any other unsuitable use.
- * Tampering or damages ensuing from use by non-authorized staff and/or use of non-original parts and/or spare parts;
- * Defects and/or damages ensuing from chemical agents and/or atmospheric phenomena (e.g. burnt out material, etc.); routine maintenance and required action or checks;
- * Products lacking a plate or having a tempered plate.

1.2 Returns to credit or replace will be accepted only in exceptional cases; however returns of goods already used to credit or replace won't be accepted in any case.

The guarantee shall be effective for all Motive products, with a term of validity of 12 months, starting from the date of shipment.

The guarantee shall be subject to specific written request for Motive to take action, according to statements, as described at

the paragraphs herein below. By virtue of aforesaid approval, and as regards the claim, Motive shall be bound at its discretion, and within a reasonable time-limit, to alternatively take the following actions:

- a) To supply the Buyer with products of the same type and quality as those having proven defective and not complying with agreements, free ex-works; in aforesaid case, Motive shall have the right to request, at Buyer's charge, early return of defective goods, which shall become Motive's property;
- b) To repair, at its charge, the defective product or to modify the product which does not comply with agreements, by performing aforesaid action at its facilities; in aforesaid cases, all costs regarding product transport shall be sustained by the Buyer.
- c) To send spare parts free of charge: all costs regarding product transport shall be sustained by the Buyer.

1.3. The guarantee herein shall assimilate and replace legal guarantees for defects and discrepancies, and shall exclude any other eventual Motive liability, however caused by supplied products; in particular, the Buyer shall have no right to submit any further claims.

Motive shall not be liable for the enforcement of any further claims, as of the date the guarantee's term of validity expires.

ARTICLE 2 CLAIMS

2.1. Claims, regarding quantity, weight, gross weight and colour, or claims regarding faults and defects in quality or compliance, and which the Buyer may discover on goods delivery, shall be submitted by a max. 7 days of aforesaid discovery, under penalty of nullity.

ARTICLE 3 DELIVERY

3.1. Any liability for damages ensuing from total or partial delayed or failed delivery, shall be excluded.

3.2. Unless differently communicated by written to the Client, the transport terms have to be intended ex-works.

ARTICLE 4 PAYMENT

4.1. Any delayed or irregular payments shall entitle Motive to cancel ongoing agreement, including agreements which do not regard the payments at issue, as well as entitling Motive to claim damages, if any. Motive shall, however, have the right, as of payment's due date and without placing in arrears, to claim interest for arrears, to the extent of the discount rate in force in Italy, increased by 5 points. Motive shall also have the right to withhold material under repair for replacement. In the case of failed payment, Motive shall have the right to cancel all guarantees of materials, as regards the insolvent Client.

4.2. The Buyer shall be bound to complete payment, including cases whereby claims or disputes are underway.

ALL DATA HAVE BEEN WRITTEN AND CHECKED WITH THE GREATEST CARE. WE DO NOT TAKE ANY RESPONSIBILITY FOR POSSIBLE ERRORS OR OMISSIONS. MOTIVE CAN CHANGE THE CHARACTERISTIC OF THE SOLD ITEMS ON HIS FIRM OPINION AND IN EVERY MOMENT.

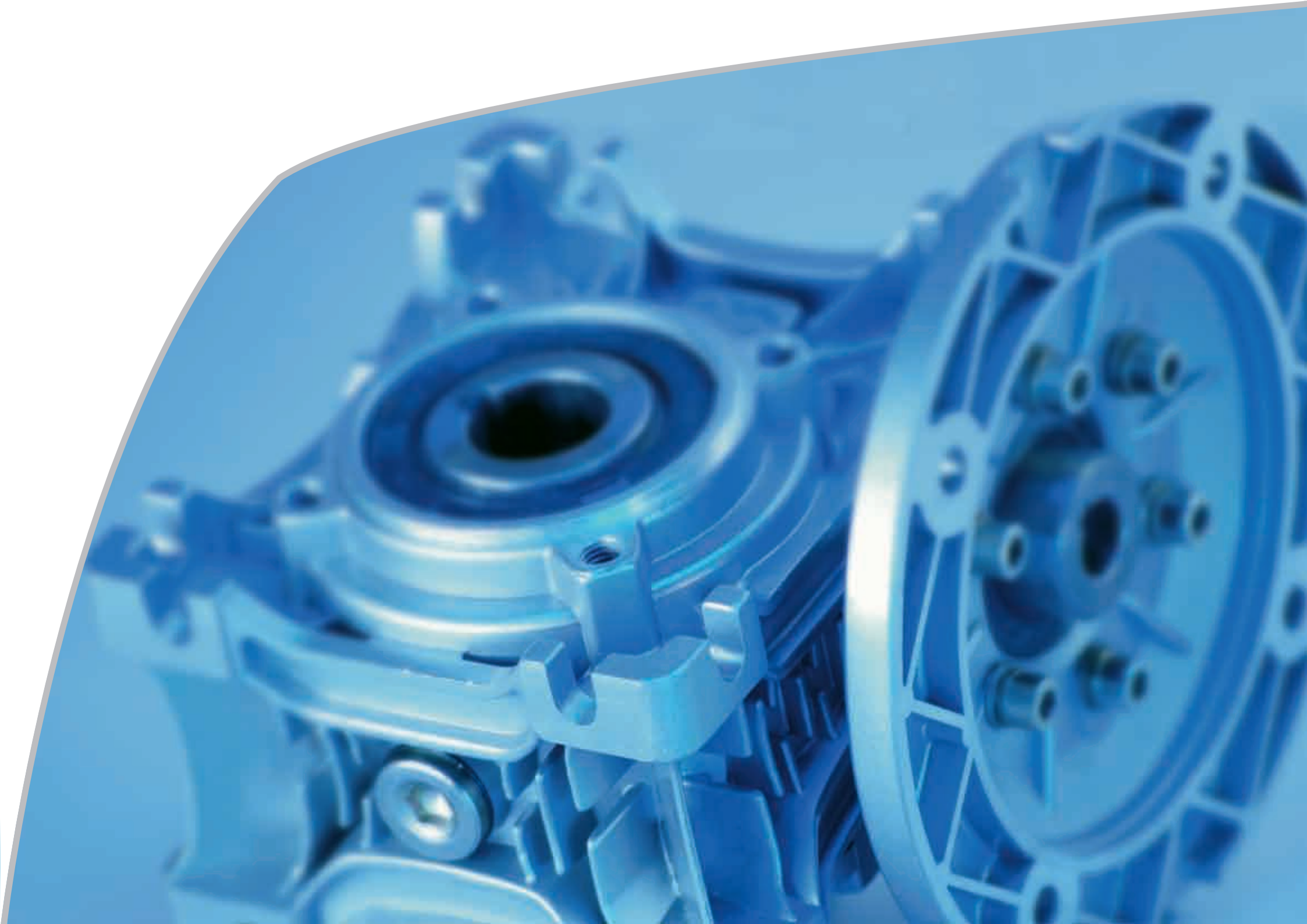



Motive s.r.l.

Via Artigianale, 110/112

25010 Montirone (BS) - Italy

Tel.: +39.030.2677087 - Fax: +39.030.2677125

web site: www.motive.it

e-mail: motive@e-motive.it



AREA DISTRIBUTOR

