

# MCD SERIES

## MANUAL CONDENSATE DRAIN

operating pressure	<b>0 - 20 bar</b>
operating temp. range	<b>1,5 to 65 °C</b>

### APPLICATIONS

- air filter

### DESCRIPTION

MCD is designed for the discharging of condensate or any other non-aggressive fluid from compressed air<sup>(1)</sup> system. In order to prevent condensate from re-entering in the airstream we recommend controlling the condensate level in filter bowl, which requires an automatic drain trap.

MCD is easy to install on the filter housing. MCD can be used in variety of applications.

<sup>(1)</sup>For any other technical gas please contact producer or your local distributor.



TECHNICAL DATA	MCD	MCDi
Operating temp. range	1,5 - 65 °C (35-149 °F)	1,5 - 65 °C (35-149 °F)
Operating pressure	0-20 bar (290 psi)	0-20 bar (290 psi)
Mass	0,06 kg	0,06 kg
Connection	G 1/2"	G 1/2"
Dimensions	A	38,2 mm
	B	29,2 mm
	C	9 mm
	D	G1/2"
	E	24,0 mm
Medium	Condensate (air, water, oil)	Condensate (air, water, oil)
Material	brass	stainless steel

# MCD-B SERIES

## MANUAL CONDENSATE DRAIN

operating pressure	<b>0 to 16 bar</b>
operating temp. range	<b>1,5 to 65 °C</b>

### APPLICATIONS

- air filter

### DESCRIPTION

MCD-B is designed for manual discharging of condensate or any other non-aggressive fluid from compressed air<sup>(1)</sup> system. MCD-B is easy to install on the filter housing. Condensate can be drained only manually. MCD-B is closed even if the system is non-pressurized.

MCD-B can be used in variety of applications.

<sup>(1)</sup>For any other technical gas please contact producer or your local distributor.

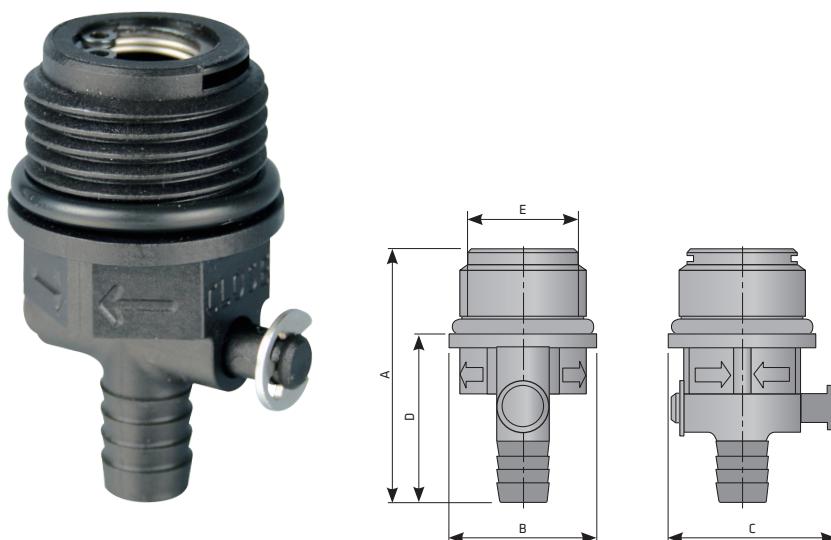

TECHNICAL DATA	MCD-B	
Operating temp. range	1,5 - 65 °C (35-149 °F)	
Operating pressure	0 - 16 bar (0 - 232 psi)	
Mass	0,011 kg	
Connection	G 1/2"	
Dimensions	A	41,5 mm
	B	ø24,0 mm
	C	27,5mm
	D	27,5mm
	E	G1/2"
Medium	Condensate (air, water, oil)	