

TD M SERIES

TIMER CONTROLLED CONDENSATE DRAIN

operating pressure	16, 25, 50, 150 bar
drain capacity	95 l/h
connections	1/2"
operating temp. range	1,5 to 65 °C

APPLICATIONS

- air compressor (piston or screw)
- after-cooler
- cyclone condensate separator
- pressure vessel/Air tank
- air dryer
- air filter

DESCRIPTION

TD M timer controlled condensate drain is designed for reliable removal of condensate or other liquid from compressed air system⁽¹⁾. Discharge intervals can be set with two adjustment knobs. TD M drain is available in several types based on operating pressure and operating medium.

TD M can be used in variety of applications. For applications not listed please contact us or your local dealer.

⁽¹⁾For any other technical gas please contact producer or your local distributor.



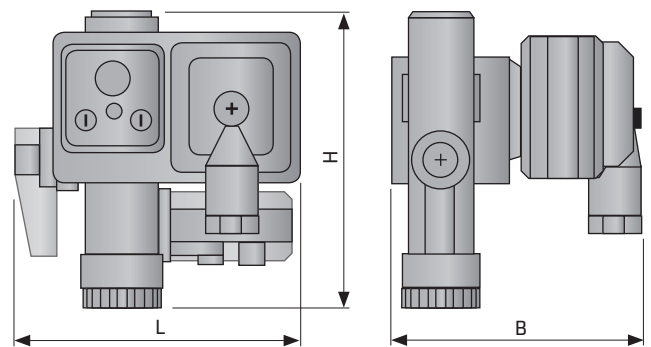

TECHNICAL DATA	TD16M		TD25M		TD50M		TD150M		TD16Mcr	
	115V	230V	115V	230V	115V	230V	115V	230V	115V	230V
Supply voltage	115V	230V	115V	230V	115V	230V	115V	230V	115V	230V
Operating temp. range	1,5 - 65 °C (35-149 °F)		1,5 - 65 °C (35-149 °F)		1,5 - 65 °C (35-149 °F)		1,5 - 65 °C (35-149 °F)		1,5 - 65 °C (35-149 °F)	
Operating pressure	16 bar (232 psi)		25 bar (362 psi)		50 bar (735 psi)		150 bar (2175 psi)		16 bar (232 psi)	
Protection class	IP65		IP65		IP65		IP65		IP65	
Coil power	18VA (holding), 36 VA (inrush)		18VA (holding), 36 VA (inrush)		18VA (holding), 36 VA (inrush)		18VA (holding), 36 VA (inrush)		18VA (holding), 36 VA (inrush)	
Cable dimensions	3 × 0,75 mm ²		3 × 0,75 mm ²		3 × 0,75 mm ²		3 × 0,75 mm ²		3 × 0,75 mm ²	
Mass (cable+valve)	0,35 kg		0,35 kg		0,35 kg		0,35 kg		0,35 kg	
Mass (strainer)	0,23 kg		0,23 kg		0,23 kg		-		0,23 kg	
Time ON	0,5 s - 10 s		0,5 s - 10 s		0,5 s - 10 s		0,5 s - 10 s		0,5 s - 10 s	
Time OFF	0,5 min - 45 min		0,5 min - 45 min		0,5 min - 45 min		0,5 min - 45 min		0,5 min - 45 min	
Drain capacity (at 7 bar)	95 l/h		95 l/h		95 l/h		95 l/h		95 l/h	
Flow rate Kvs	2,4 l/min		1,5 l/min		0,7 l/min		0,7 l/min		3,4 l/min	
Inlet connection	R 1/2"		R 1/2"		R 1/2"		R 1/2"		R 1/2"	
Outlet connection	R 1/4"		R 1/4"		R 1/4"		R 1/4"		R 1/4"	
Dimensions LxBxH [mm]	77x79x93	87,5x90,5x123	77x79x93	87,5x90,5x123	77x79x93	87,5x90,5x123	77x79x93	87,5x90,5x123	77x79x93	87,5x90,5x123
Medium	Air, water, oil		Air, water, oil		Air, water, oil		Air, water, oil		Aggressive fluids	
Option strainer	yes		yes		yes		no		no	