

R-DRY SERIES

HEAT REGENERATED ADSORPTION DRYERS

operating pressure	4 to 11 bar
operating temp.range	1,5 to 50 °C
pressure dew points	-40 °C
flow rate	390 to 20.200 Nm ³ /h

APPLICATIONS

- compressed air systems

DESCRIPTION

R-DRY 400 - 20000 adsorption dryers are designed for continuous separation of water vapour from compressed air thus reducing dew point. Operation of dryer requires two columns operated alternately. Adsorption takes place under pressure in first column while second column regenerates with a heated ambient air or purge.

A dryer consists of two columns, filled with desiccant beads, blower, heater, controller with LCD display, valves, manometers, and support construction. Proven robust design enables efficient and reliable operation, fast installation and simple maintenance.



DRYER TYPE	REGENERATION	COOLING
BP	blower, ambient air	purge air
BVA	blower, ambient air	blower, vacuum air

Protection class	IP 54
Filter (inlet)	super fine - 0,01 µm
Filter (outlet)	dust filter; 1 µm
Column insulation	optional

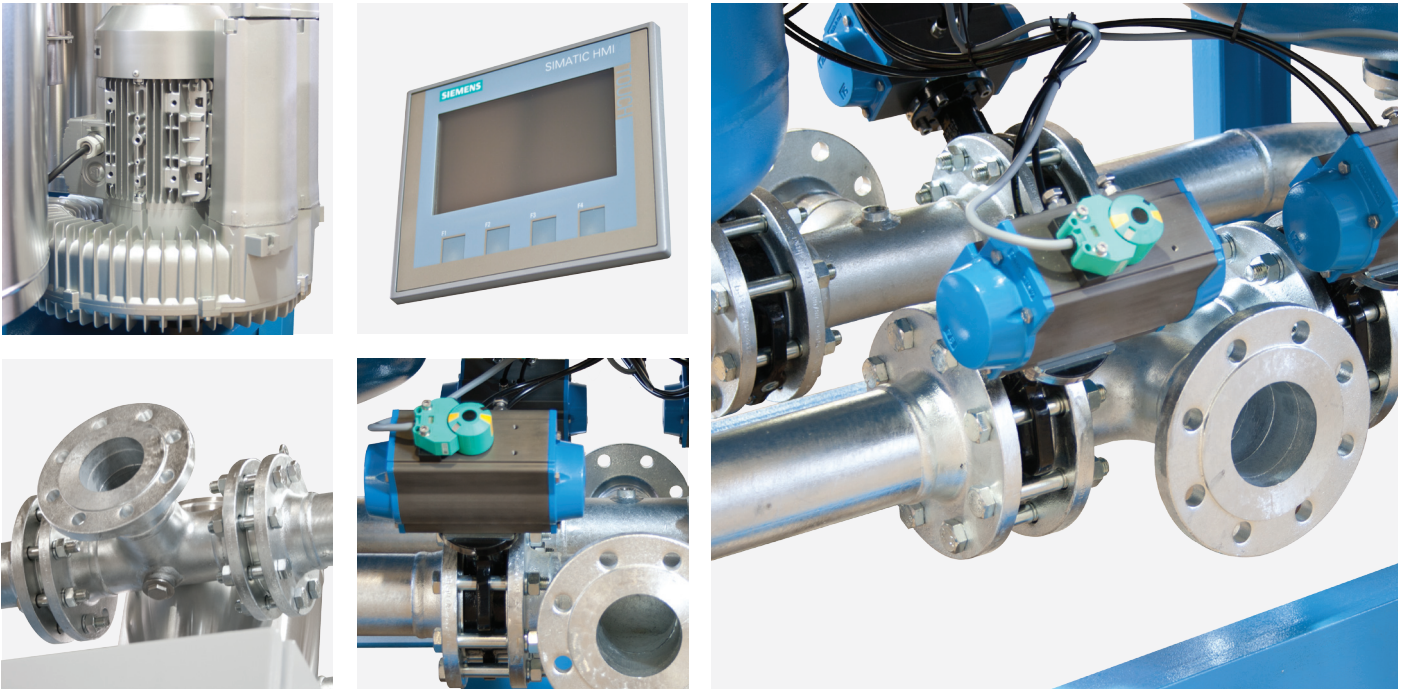

TECHNICAL DATA

Type	Connection IN/OUT	Nominal volume flow	Dimensions			Mass
		Inlet	A [mm]	B [mm]	C [mm]	
	DN	[Nm ³ /h]				kg
R-DRY 400	DN50	390	1200	1000	2250	1000
R-DRY 600	DN50	590	1300	1100	2350	1400
R-DRY 780	DN50	780	1300	1100	2350	1800
R-DRY 1000	DN50	930	1450	1250	2600	1900
R-DRY 1200	DN80	1.150	1450	1250	2700	2200
R-DRY 1600	DN80	1.600	1550	1350	2750	2600
R-DRY 2000	DN100	1.950	1600	1450	2800	3400
R-DRY 2500	DN100	2.530	2050	1500	2900	3800
R-DRY 3000	DN100	2.990	2050	1550	2950	5000
R-DRY 3600	DN100	3.680	2150	1600	3000	5800
R-DRY 4100	DN125	4.100	2350	1600	3250	7000
R-DRY 5000	DN125	4.990	2500	1750	3250	8200
R-DRY 6500	DN150	6.550	2600	2000	3500	10200
R-DRY 7700	DN150	7.700	2900	2000	3600	12000
R-DRY 10000	DN200	10.250	3200	2200	3600	14400
R-DRY 12000	DN200	11.700	4200	2500	3700	16000
R-DRY 14000	DN200	14.800	4500	2600	3750	16800
R-DRY 16000	DN250	16.000	5500	3200	3750	18500
R-DRY 18000	DN250	18.200	6000	3500	3750	20000
R-DRY 20000	DN250	20.200	6000	3800	3750	23000

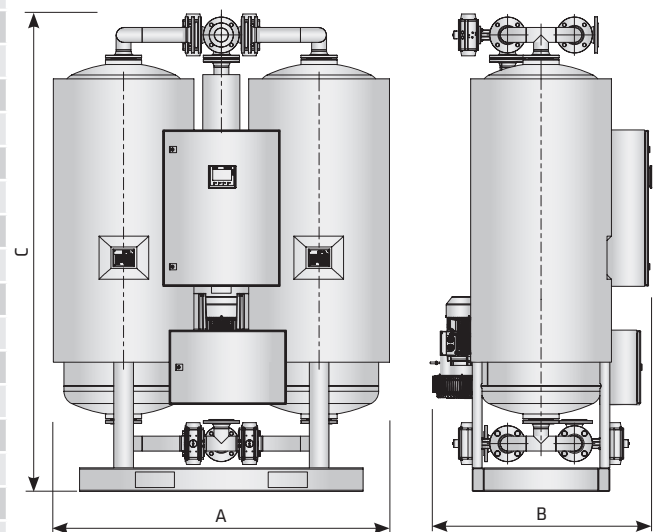

OPERATING PRESSURE - CORRECTION FACTORS - C_{OP}

	2	3	4	5	6	7	8	9	10	11
Operating pressure [bar]										
Operating pressure [psi]	29	44	58	72	87	100	115	130	145	160
Correction factor C _{OP}	0,38	0,5	0,63	0,75	0,88	1	1,13	1,25	1,38	1,50

OPERATING TEMPERATURE - CORRECTION FACTORS - C_{OT}

	25	30	35	40	45	50
Operat. temperature [°C]						
Operat. temperature [F]	77	86	95	104	113	122
Correction factor C _{OT}	1	1	1	0,97	0,87	0,80

⁽¹⁾ Refers to 1bar(a) and 20°C at 7 bar operating pressure, inlet temperature 35°C and pressure dew point at outlet -40°C.