

# M-DRY SERIES

## MEMBRANE DRYERS

operating pressure	<b>0 to 12 bar</b>
operating temp.range	<b>1,5 to 60 °C</b>
pressure dew points	<b>+15, +3, -20, -40°C</b>
flow rate	<b>3 to 180 Nm<sup>3</sup>/h</b>

### APPLICATIONS

- automotive painting
- industrial "Point-of-use" drying
- low dew point instrument air
- pneumatics
- medical air
- analytical equipment
- pressurizing electrical cabinets

### DESCRIPTION

M-DRY membrane air dryers have been developed for high efficient removal of water vapours from compressed air. Super fine coalescing filter is required upstream.



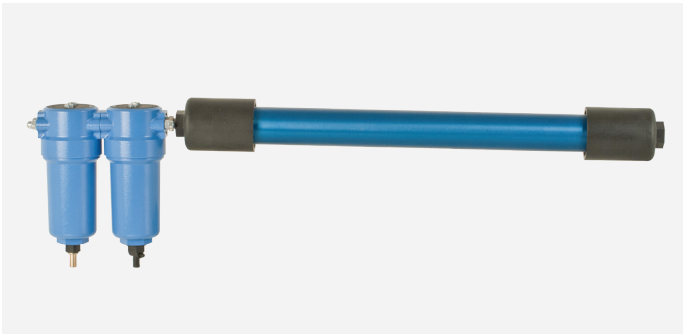

TECHNICAL DATA									
Model	Pipe size		Operating pressure		Flow rate *		Dimensions [mm]		
	inch	bar	Nm <sup>3</sup> /h	scfm	A	B	C	D	
M-DRY 3	1/4	12	3	1,8	224	43,7	325	175	
M-DRY 6	1/4	12	6	3,5	325	43,7	453	175	
M-DRY 9	1/4	12	9	5,3	427	43,7	555	175	
M-DRY 12	1/4	12	12	7,1	503	43,7	611	175	
M-DRY 18	1/2	12	18	10,6	312	61	476	208	
M-DRY 24	1/2	12	24	14,1	376	61	540	208	
M-DRY 32	1/2	12	36	21,2	465	61	661	208	
M-DRY 44	1/2	12	48	28,3	592	61	788	208	
M-DRY 63	1/2	12	63	37,1	411	89	607	208	
M-DRY 90	1/2	12	90	53	551	89	755	284	
M-DRY 123	1/2	12	123	72,4	551	89	755	284	
M-DRY 180	1	12	180	106,6	607	114	1805	290	

\*At 7 bar, inlet dew point +35 °C, outlet dew point +15 °C

PERFORMANCE DATA									
Outlet dew point	15 °C		3 °C		-20 °C		-40 °C		
Purge air consumption	10 %		14 %		21 %		29 %		
% Water removal	69,70 %		86,53 %		98,20 %		99,77 %		
	Nm <sup>3</sup> /h	scfm	Nm <sup>3</sup> /h	scfm	Nm <sup>3</sup> /h	scfm	Nm <sup>3</sup> /h	scfm	
MFP 3	3	1,8	2,2	1,3	1,4	0,8	1,02	0,6	
MFP 6	6	3,5	4,3	2,5	2,8	1,7	2	1,2	
MFP 9	9	5,3	6,4	3,8	4,3	2,5	3,1	1,8	
MFP 12	12	7,1	8,5	5,0	5,7	3,3	4,1	2,4	
MFP 18	18	10,6	12,8	7,5	8,5	5,0	6,2	3,6	
MFP 24	24	14,1	17	10,1	11,3	6,7	8,2	4,8	
MFP 32	36	21,2	25,6	15,1	17	10	12,4	7,3	
MFP 44	48	28,3	34,1	20,1	22,7	13,4	16,4	9,7	
MFP 63	63	37,1	44,9	26,4	29,7	17,5	21,5	12,7	
MFP 90	90	53	67,3	39,6	43,8	25,8	31,1	18,3	
MFP 123	123	72,4	91,7	54,0	58,8	34,6	42,6	25,1	
MFP 180	180	106,6	128,1	75,4	85,5	50,3	61,5	36,2	

At 7 bar, inlet dew point +35 °C, data refers on inlet flow capacity

CORRECTION FACTORS									
Operating pressure [bar]	4	5	6	7	8	9	10	11	12
Operating pressure [psi]	58	72	87	100	115	130	145	160	174
C <sub>op</sub>	0,41	0,56	0,76	1	1,22	1,48	1,76	1,86	2,22

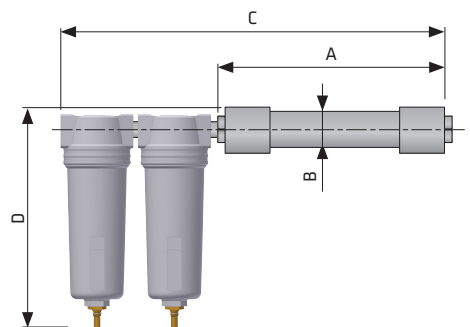

quality class - solids (ISO 8573-1)	-
quality class - water (ISO 8573-1)	2*
quality class - oils (ISO 8573-1)	-
differential pressure [mbar / psi]	200 / 2,9
required inlet air quality (particles)	class 1
required inlet air quality (oil)	class 1 <0,01 mg/m <sup>3</sup>

\*Outlet dew point depend on inlet conditions and flow. For specific operating conditions check tables.