

A-DRY SERIES

HEATLESS ADSORPTION DRYERS

operating pressure	4 to 16 bar
temp. operating range	1,5 to 50 °C
pressure dew points	-40°C (-25°C / -70°C)
flow rate	6 to 200 Nm³/h

APPLICATIONS

- compressed air systems

DESCRIPTION

A-DRY desiccant adsorption dryer has been designed to separate water moisture from compressed air thus reducing the dew point in the system. A-DRY is a range of products offering our customers a wide array of dried air solutions with volumetric flow rates ranging from 6 Nm³/h to 200 Nm³/h.

An innovative new design of A-DRY adsorption driers, developed with consideration of our customers, enables fast and reliable installation, use and servicing. Installation is simple with our ready to use controller while minimising the number of parts and motions required for assembly and disassembly makes servicing fast and reliable.



ADVANTAGES

- ✓ Wide range of products to fit your need.
- ✓ Robust and intuitive ready to use controller.
- ✓ Simple assembly and disassembly.
- ✓ Fast and reliable servicing.
- ✓ Adsorbent in cartridges
- ✓ Standard version includes coalescing pre-filter and particle afterfilter

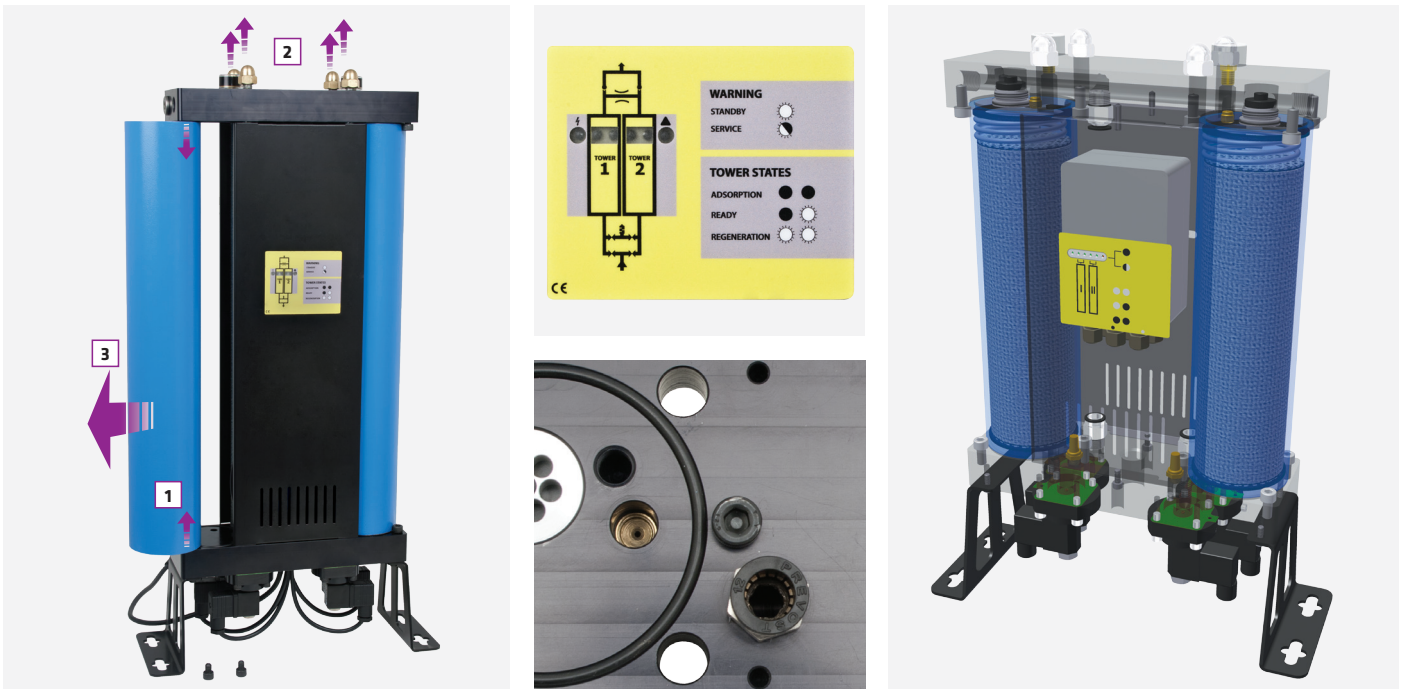

TECHNICAL DATA

Type	Connection IN/OUT	Nominal volume flow		Dimensions						Mass kg
		Inlet ¹	Outlet ²	A [mm]	A* [mm]	B [mm]	B* [mm]	C [mm]	C* [mm]	
		[Nm ³ /h]	[Nm ³ /h]							
A-DRY 06	G3/8"	6	4,7	339	404	288	552	100	120	10,5
A-DRY 12	G3/8"	12	9,4	573	638	288	552	100	120	13,5
A-DRY 24	G3/8"	24	18,8	1041	1106	288	552	100	120	19,0
A-DRY 36	G3/8"	36	28,2	1509	1574	288	552	100	120	27,5
A-DRY 60	G1/2"	60	47,0	1041	1106	370	634	148	170	45,0
A-DRY 75	G1/2"	75	58,8	1275	1340	370	634	148	170	53,0
A-DRY 105	G1/2"	105	61,8	1743	1808	370	634	148	170	70,0
A-DRY 150	G1"	150	88,3	1345	1455	440	815	198	240	170,5
A-DRY 200	G1"	200	117,7	1538	1648	440	815	198	240	182,2

Operating pressure range	4 to 16 bar
Operating temperature range	+1,5 °C to +50 °C
Pressure dew points	-25 °C / -40 °C / -70 °C
Voltage, frequency	230V, 50/60 Hz
Power consumption	<30 W
Protection class	IP 65
Filter (inlet)*	super fine - 0,01 µm
Filter (outlet)	dust filter; 1 µm

⁽¹⁾ Refers to 1bar(a) and 20°C at 7 bar operating pressure, inlet temperature 35°C and pressure dew point at outlet -40°C.

⁽²⁾ Outlet flow refers to typical assumption during regeneration phase for operating at nominal inlet flow conditions. Outlet flow includes average air losses of approximately 17,3 %.

* If dryer is supplied without inlet filter compressed air class 1 (ISO 8753-1) for solid particles and oil should be provided to the inlet of the dryer.

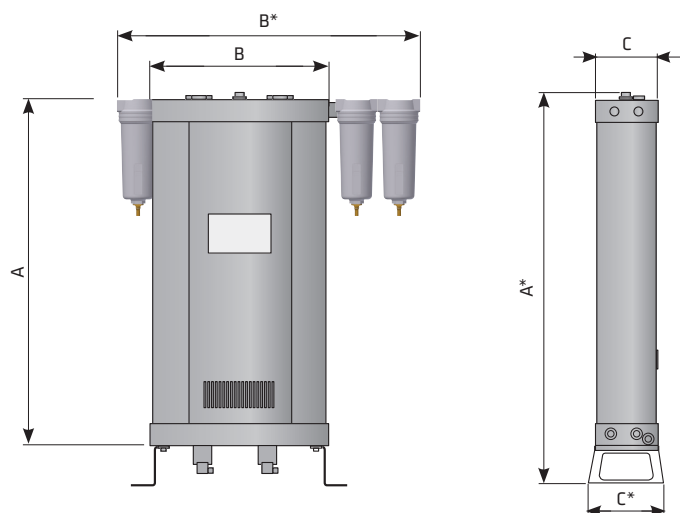

CORRECTION FACTORS - F1

Operating pressure [bar]	2	3	4	5	6	7	8	9	10	11	12	13	14	15	16
Operating pressure [psi]	29	44	58	72	87	100	115	130	145	160	174	189	203	218	232
Correction factor	0,38	0,5	0,63	0,75	0,88	1	1,13	1,25	1,38	1,50	1,63	1,75	1,88	2,00	2,13

CORRECTION FACTORS - F2

Inlet temperature [°C]	25	30	35	40	45	50
Correction factor	1,00	1,00	1,00	0,97	0,87	0,80

DEW POINT

[°C]	-25	-40	-70
C ₀	1,1	1	0,7