



Engineered Materials Group

Sealing Solutions and Engineered Polymer Products



ENGINEERING YOUR SUCCESS.

Engineered Materials Group Europe

A Global and Local Player

The Engineered Materials Group of the Parker Hannifin Corporation is the global leader in the field of designing, developing and manufacturing sealing systems, engineered components made from polymer materials, EMI shielding systems and heat dissipation materials.

Fields of application range from mobile and stationary hydraulics, pneumatics, machinery and plant engineering, automotive engineering, the (bio-) chemical, pharmaceutical and medical (life sciences) sector, food processing, oil and gas, aerospace and semi-conductors through to electronics and telecommunications.

In addition to standard sealing elements and sealing systems, the product portfolio encompasses a wide range of special profiles and geometries as well as other engineered components, in- and outside sealing technology. Furthermore, the Engineered Materials Group offers a variety of services such as testing, kit service, product identification and much more.

Special importance is always attached to the sustainability of the products and solutions in the interest of benefiting the customer and the environment through optimum energy efficiency, reliability, durability and economy.

With strong in-house compound and design expertise, testing and process technology plus state-of-the-art manufacturing facilities the Parker Engineered Materials Group offers a wide portfolio ranging from standard products through to tailored new and system developments. The latter frequently result from close development partnerships with customers in keeping with Parker's motto:

ENGINEERING YOUR SUCCESS.



Bietigheim-Bissingen (DE)



Pleidelsheim (DE)



Gryfino (PL)



Helsingør (DK)

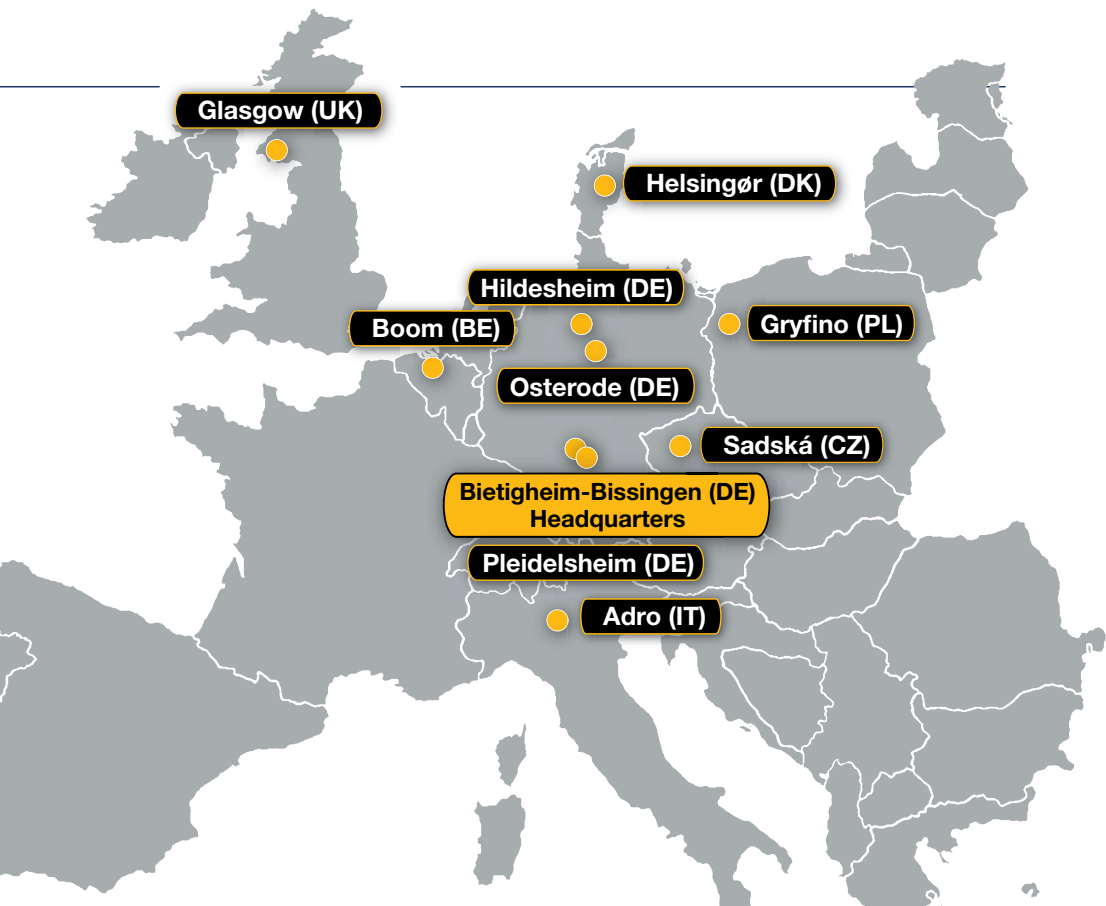

Adro (IT)



Boom (BE)



Glasgow (UK)

~ 1,500
Employees

< 5,500
Customers



Hildesheim (DE)



Osterode (DE)



Sadská (CZ)

135,000
Part numbers

1.275 billion
Products/year

Engineered Materials Group Europe

Our Core Competencies

Material Science and Process Technology

60 Years of Experience

Performance Evaluation

Physical Trials and
Validation of Developments

State-of- the-Art Production Facilities

10 Manufacturing
Sites in Europe



Product Development

Computer Simulation
Prototyping



State-of-the-Art Production Capabilities

Manufacturing Plants
Europe

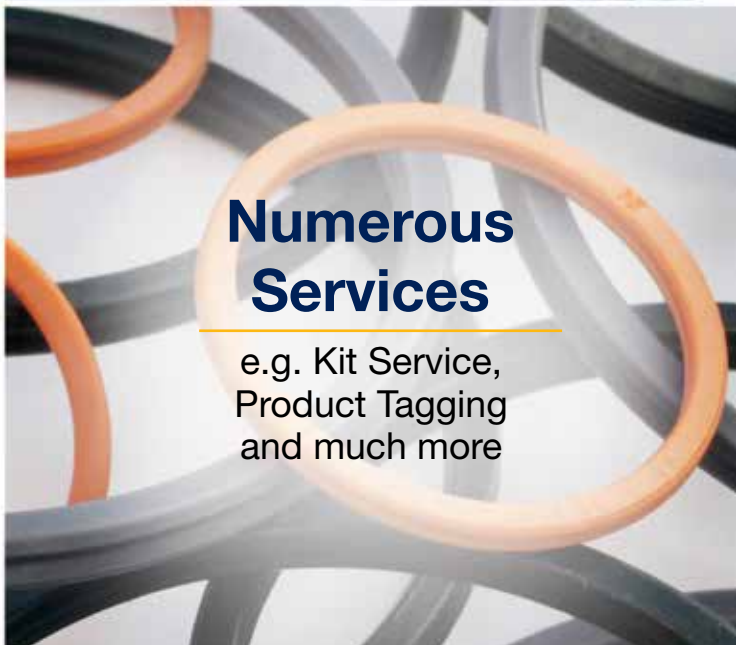

Numerous Services

e.g. Kit Service,
Product Tagging
and much more

Engineered Materials Group Europe

Product Portfolio

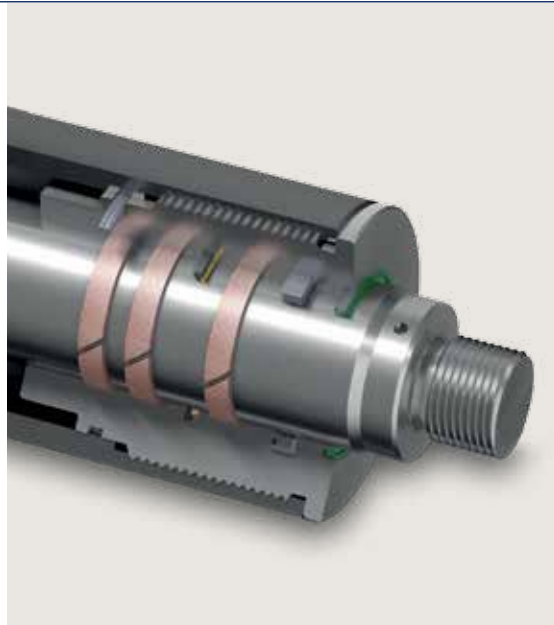

More than 300 compounds

*Numerous standard products
and tailor-made solutions*

Sealing Solutions

- Static seals
- Seals for translatory movement:
cylinder seals
- Seals for rotary movement:
shaft seals
- Diaphragms
- Energy absorption:
damping elements



Static Seals

- O-rings
- Back-up rings
- Molded shapes
- 2K rubber-plastic moldings
- Cut seals

Custom Sealing Solutions and Sealing Systems

- Individual sealing components
- Specific sealing systems

Composites

Multi-component molded shapes and profiles

Engineered Polymer Products

- Individual solutions
- According to customer specification
- Exclusivity



Parker Hannifin GmbH
Engineered Materials Group Europe
Arnold-Jäger-Strasse 1
74321 Bietigheim-Bissingen (Germany)
phone +49 7142 351-0 · fax +49 7142 351-432
praedifa@parker.com

www.parker.com/praedifa