

Symbol

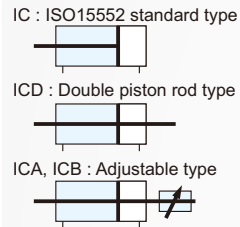

Features

- * Identical to ISO15552 standard.
- * High quality of aluminum tube provides a long service life.
- * High quality of seals ensures leakage free.
- * Various sensors for option.
- * With adjustable cushions on both ends.

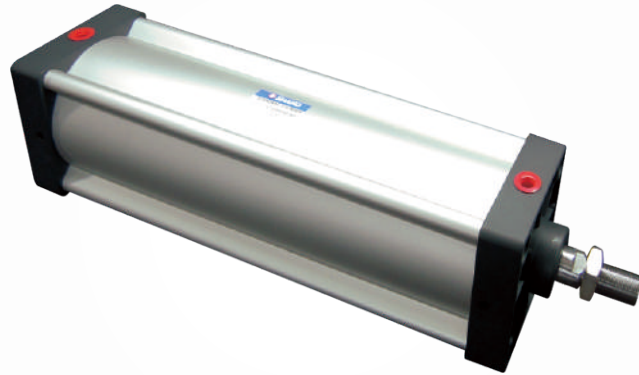

How to order

IC	125	B	50	SF	1	FA	FY
Type	Bore size	Magnet	Stroke	Sensor type	Number of sensor	Mounting parts	Rod end joint
IC ISO15552 standard type	125 φ 125	B W/I magnet		Blank W/O sensor	1 pc	Blank W/O mounting parts	Blank W/O rod end joint
ICD Double piston rod type	160 φ 160	C W/O magnet		SF LED in front	2 pcs	FA Front flange	FY Double knuckle joint
ICA Stroke adjustable 25mm	200 φ 200			AL-20R		FB Rear flange	FI Single knuckle joint
ICB Stroke adjustable 50mm				ST LED on top		CA Male clevis	FP Eyebolt floating joint
						CB Female clevis	FT Basic floating joint
						LB Foot mounting	

How to order Mounting parts / Rod end joints

ZI	FA	ZN	FY	125
IC series	Mounting parts		Rod end joint	Bore size
Blank	W/O mounting parts	CA	Male clevis	125 φ 125
FA	Front flange	CB	Female clevis	160 φ 160
FB	Rear flange	LB	Foot mounting	200 φ 200
			Blank	W/O rod end joint
			FY	Double knuckle joint
			FI	Single knuckle joint
			FP	Eyebolt floating joint
			FT	Basic floating joint

* Please refer to P5-10~11

* Please refer to P5-40~41

Specifications

Bore size	φ 125	φ 160	φ 200
Port size	1/2"	3/4"	
Fluid	Compressed air		
Acting	Double acting		
Operating pressure range	1.5 ~ 9.5 kgf/cm ²		
Barrel material	Aluminum alloy		
Cushion	Built in		
Magnet	Option		
Ambient temperature	-5°C ~ 60°C		
Piston speed	50~700mm/Sec.		

Dimensions

- ISO15552 standard type
- IC125~IC200

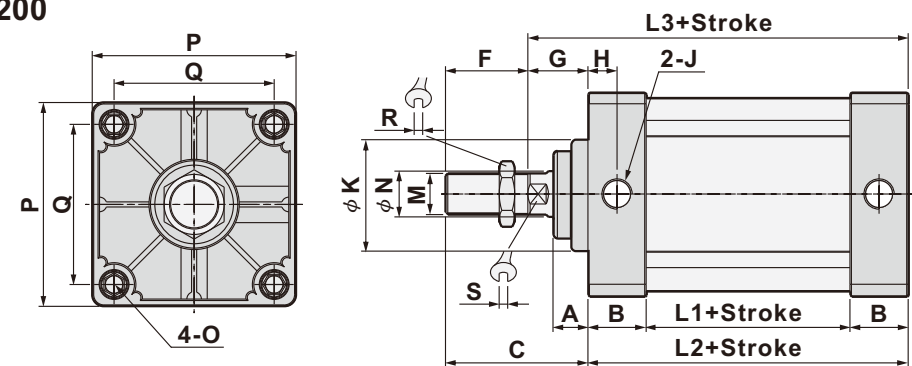

- ICD125~ICD200

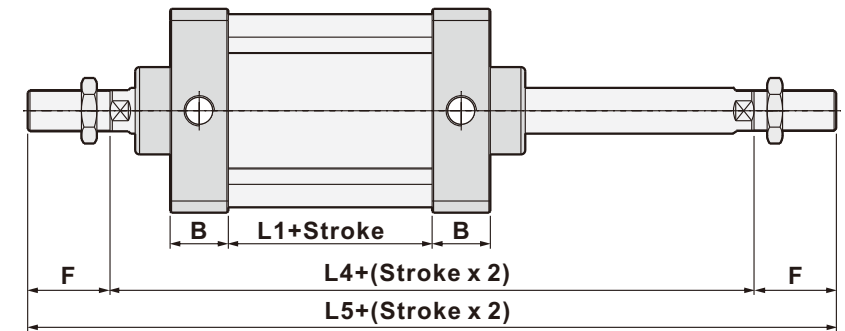

- ICA125~ICA200
- ICB125~ICB200

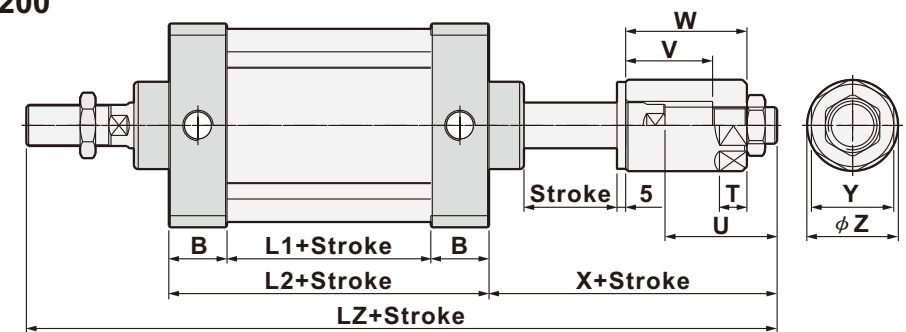

(Unit: mm)

Bore size	A	B	C	D	F	G	H	I	J	K	M	N	O	L1	L2	L3	L4	L5
φ 125	24.5	40	119	8	54	65	23	110	G1/2	60	M27xP2	φ 32	M12	80	160	225	290	398
φ 160	38	45	152	7	72	80	25	140	G3/4	65	M36xP2	φ 40	M16	80	180	260	340	484
φ 200	67	45	167	8	72	95	25	175	G3/4	75	M36xP2	φ 40	M16	84	184	279	374	518

Bore size	ICA	ICB	ICA	ICB	ICA	ICB	ICA	ICB	ICA	ICB	P	Q	R	S	T	Y	Z
φ 125	409	434	65	90	57	82	74	99	130	155	140	110	40	27	21	50	55
φ 160	491	516	79	104	69	94	89	114	159	184	180	140	50	36	21	55	60
φ 200	525	550	79	104	69	94	89	114	174	199	220	175	50	36	21	55	60

Dimension of mounting parts

CA, CB Clevis mounting

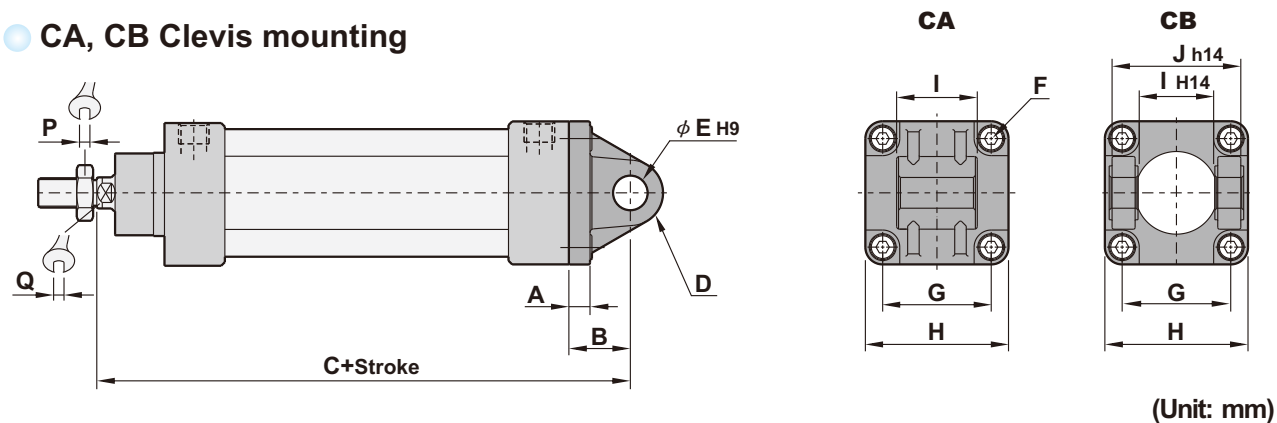

(Unit: mm)

Bore size	A		B	C	D	E	F	G	H	I	J	P	Q
	CA	CB											
φ 32	10	10	22	142	R11	φ 10	M6	32.5	46	26 ^{-0.2} _{-0.6}	45	17	10
φ 40	10	10	25	160.8	R13	φ 12	M6	38	54	28 ^{-0.2} _{-0.6}	52	19	13
φ 50	13	13	28	170	R13	φ 12	M8	46.5	64	32 ^{-0.2} _{-0.6}	60	24	17
φ 63	13	13	33	190	R17	φ 16	M8	56.5	77	40 ^{-0.2} _{-0.6}	70	24	17
φ 80	15	15	35	210.8	R17	φ 16	M10	72	94	50 ^{-0.2} _{-0.6}	90	26	22
φ 100	15	15	40	230	R21	φ 20	M10	89	114	60 ^{-0.2} _{-0.6}	110	26	22
φ 125	17	19	50	275	R25	φ 25	M12	110	140	70 ^{-0.5} _{-1.2}	130	40	27
φ 160	19.5	19.5	55	315	R30	φ 30	M16	140	180	90 ^{-0.5} _{-1.2}	170	50	36
φ 200	23	22	60	339	R30	φ 30	M16	175	220	90 ^{-0.5} _{-1.2}	170	50	36

Dimension of mounting parts

TC Central trunnion mounting

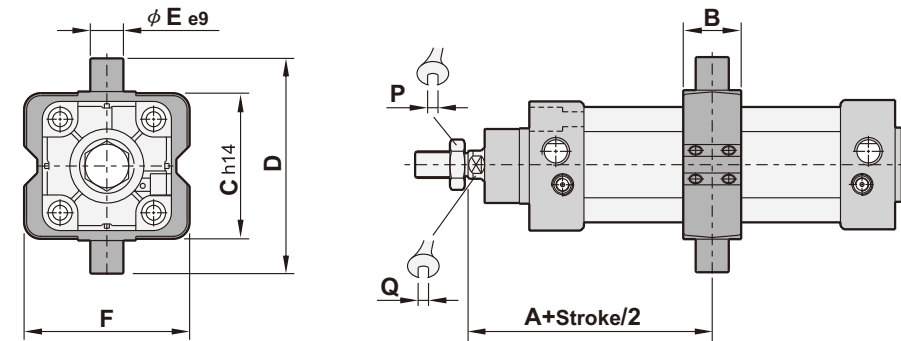

(Unit : mm)

Bore size	A	B	C	D	E	F	P	Q
φ 32	73	22	50	74	φ 12	58	17	10
φ 40	82.5	28	63	95	φ 16	70	19	13
φ 50	90	32	75	107	φ 16	85	24	17
φ 63	97.5	35	90	130	φ 20	100	24	17
φ 80	110	40	110	150	φ 20	120	26	22
φ 100	120	45	132	182	φ 25	145	26	22

FA, FB Front & Rear flange mounting

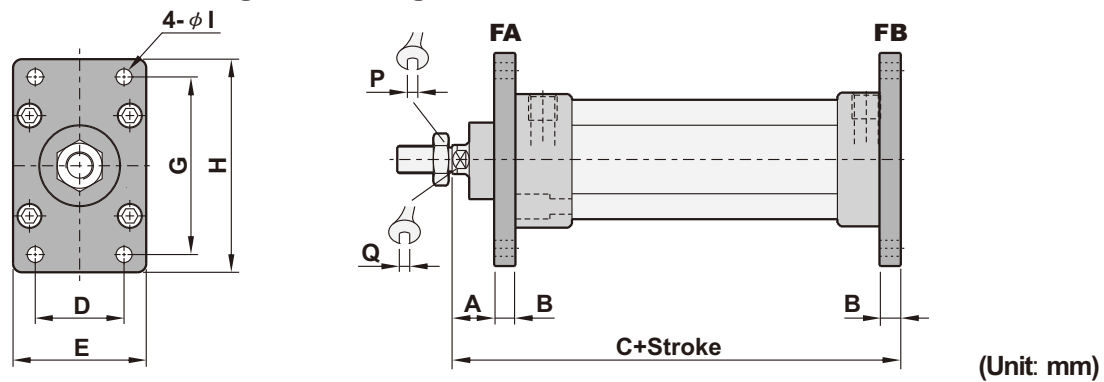

(Unit: mm)

Bore size	A	B	C	D	E	G	H	I	P	Q
φ 32	16	10	130	32	50	64	79	7	17	10
φ 40	20	10	145	36	55	72	90	9	19	13
φ 50	25	12	155	45	65	90	110	9	24	17
φ 63	25	12	170	50	75	100	120	9	24	17
φ 80	30	16	190	63	95	126	153	12	26	22
φ 100	35	16	205	75	115	150	178	14	26	22
φ 125	32	20	245	90	140	180	224	16.5	40	27
φ 160	37	20	280	115	180	230	280	18.5	50	36
φ 200	61	25	304	135	220	270	320	24	50	36

LB Foot mounting

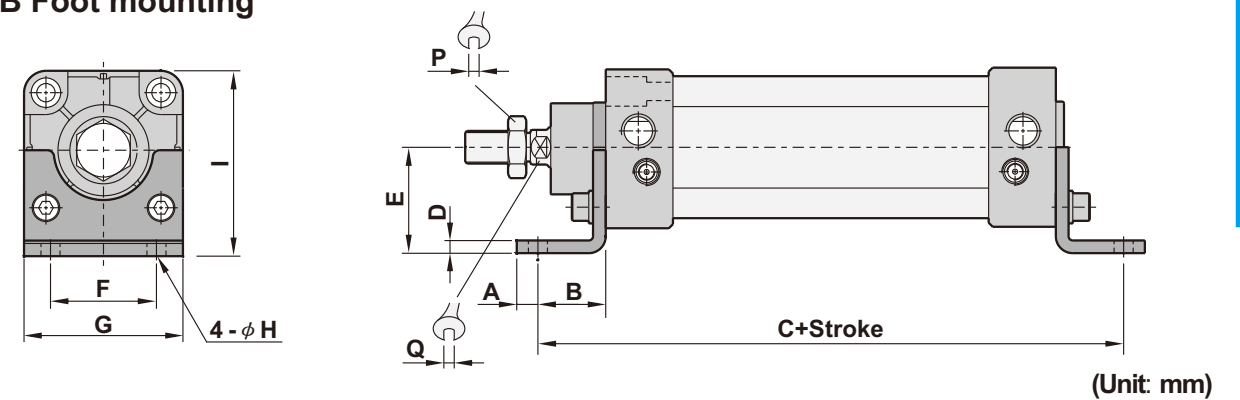

(Unit: mm)

Bore size	A	B	C	D	E	F	G	H	I	P	Q
φ 32	8	24	142	4	32	32	47	φ 7	56.5	17	10
φ 40	10	28	161	4	36	36	53	φ 9	63.5	19	13
φ 50	10	32	170	4	45	45	65	φ 9	77.5	24	17
φ 63	10	32	185	4	50	50	75	φ 9	87.5	24	17
φ 80	13	41	210	5	63	63	95	φ 12	110	26	22
φ 100	13	41	220	6	71	75	115	φ 14	127.5	26	22
φ 125	20	45	250	8	90	90	140	φ 16.5	160	40	27
φ 160	20	60	300	8	115	115	180	φ 18.5	205	50	36
φ 200	30	70	324	9	135	135	220	φ 24	245	50	36

Rod loading chart

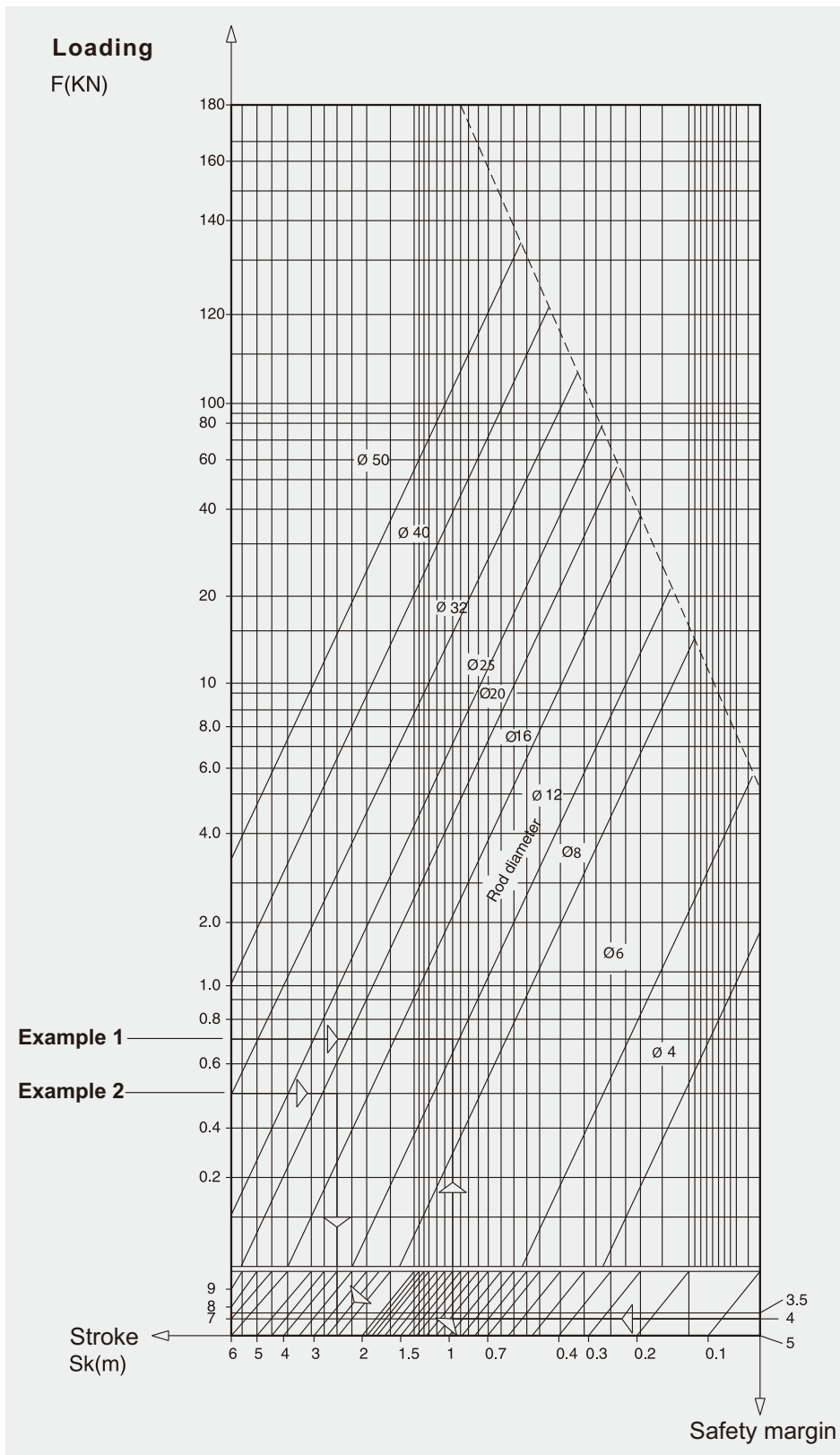

Rod swing length

● A, C, D

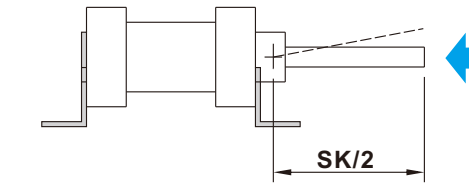

● B

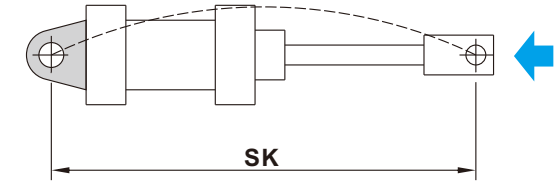

● A, C, D

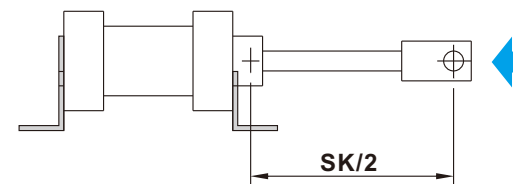

● E

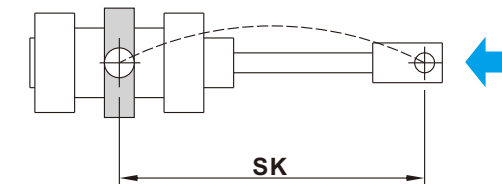

● Example 1

Piston push force: 0.7Kn
Stroke: 1000mm
Pressure: Approx. 6 bar
Mounting: C

Ans: Referring to the rod loading chart, the rod diameter location between $\phi 12 \sim \phi 16$. Consider the rod loading, the actual diameter is $\phi 16$ mm, also, we can know the cylinder body diameter is $\phi 40$ mm.

● Example 2

Cylinder diameter: $\phi 50$ mm
Rod diameter: $\phi 20$ mm
Stroke: 1000mm
Piston push force: 0.5Kn
Mounting: B

Ans: Referring to the rod loading chart, Sk=2900mm
Max stroke=1450mm