

METALDRIVE Disc couplings

METALDRIVE couplings are fully made of steel and are used in all applications where high reliability, precision and no maintenance are required.

Features

- All steel made
- Superior disc pack profile and assembly optimized for higher torque and misalignment and lower restoring forces
- Maintenance, lubrication and wear free
- Backlash free and torsionally rigid
- Wide range of temperature allowed: -40°C a 250 °C
- Available in execution conforming to ATEX 94/9/CE
- Easy installation
- Bidirectional
- Modular design
- Allow axial, angular and radial misalignment (only with double disc pack)
- Available in stainless steel for corrosive environment application

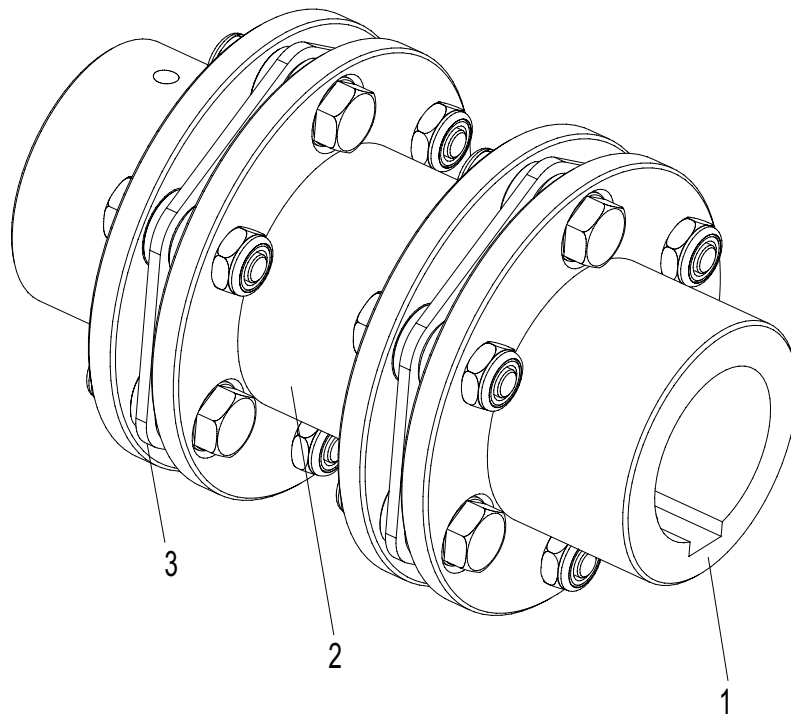

METALDRIVE couplings executions

GMD type S ●●●●

Standard version with single disc pack. The coupling allows axial and angular misalignment. No radial misalignment is allowed.

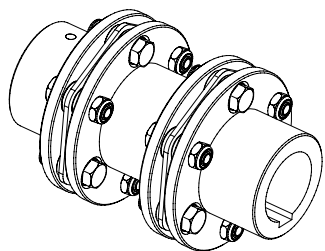
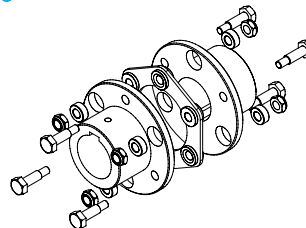

●●●● GMD type DCL / DCC / DC1MR / DC2MR / DCC1MR

Standard version with double disc pack and standard length spacer. Allow axial angular and radial misalignment. It is possible to mount the hubs reverse (hub R) to get a compact drive. In such a case it is not possible the radial mounting of the spacer.

GMD type SA1 ●●●●

Tubular shaft version. Shaft is available in various lengths and can be delivered in welded aluminium or steel.

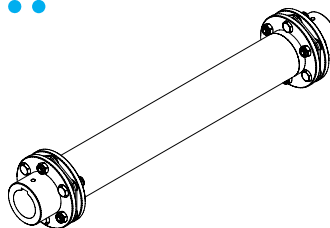

●●●● GMD type SA2

Shaft version with solid shaft construction. Variable shaft lengths are available.

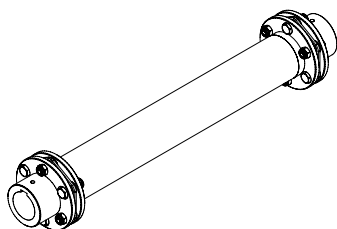

GMD type DCA ●●●●

Double disc pack execution and anti-fail device. Standard spacer lengths for pump applications. This execution is available in conformity to API 610 e API 617.

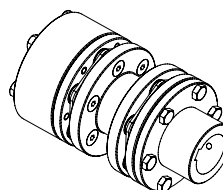

Technical characteristics

Size	Torque (Nm)			Misalignment				Max rotation speed without balancing (1/min)	Torsional stiffness per disc pack (Nm/rad •10 ⁶)
	Nominal Tkn	Max Tkmax	Reverse Tkw	Axial ΔKa (mm) per disc pack	Angular α (°) per disc pack	Radial Δkr DCL execution	Radial ΔKr (mm) with spacer		
32-6	100	200	30	0,8	0,75	0,32	$(P_1-P) \cdot \tan \alpha$	11500	0,12
38-6	150	300	50	0,9	0,75	0,42		10000	0,16
45-6	300	600	100	1,2	0,75	0,53		8200	0,42
52-6	700	1400	230	1,4	0,75	0,74		6700	0,98
65-6	1100	2200	370	1,6	0,75	0,84		5700	1,85
80-6	1700	3400	570	1,8	0,75	0,92		5000	2,24
90-6	2600	5200	870	1,8	0,75	0,96		4500	3,6
95-6	4000	8000	1330	2	0,75	1,45		4100	9
110-6	7000	14000	2330	2,2	0,75	1,45		3600	11,90
120-6	9000	18000	3000	2,4	0,75	1,6		3100	14,20
138-6	12000	24000	4000	2,6	0,75	1,6		2900	15,60
155-8	25000	50000	8330	2,9	0,5	2,95		2600	37,80
175-8	35000	70000	11670	3,1	0,5	3,15		2400	51,60
190-8	50000	100000	16670	3,4	0,5	3,4		2200	64,40
205-8	65000	130000	21670	3,8	0,5	3,85		2000	69,50

The torsional rigidity of a coupling with spacer is calculated as follows:

$$C_T = \frac{1}{\frac{2}{C_{TL}} + \frac{P_1 - 2P}{C_{TS}}}$$

With C_{TS} = spacer torsional rigidity

Operating speed must be equal or less than permissible speed.

METALDRIVE coupling balancing

All the components of the METALDRIVE couplings are completely machined (spacer excluded) and balanced in class DIN ISO 1940-1 Q 6,3. Therefore the balancing is unnecessary in most applications.

In case of higher degree of balancing is required, it is important to consider:

- Rotation speed and coupling diameter
- Rotation speed and intermediate shaft length
- Rotation speed and special balancing need of the machine

According to the requirement, METALDRIVE coupling can be statically or dynamically balanced according to DIN ISO 1940-1. As a standard, the balancing is made on the single coupling component. On specific request it can be made the balancing of the mounted set. Also as a standard the balancing is made before the key seat machining. The balancing after the key seat machining is made on specific request. Permissible speed could be limited by the weight and critical speed of spacers. Please consult with our technical department.

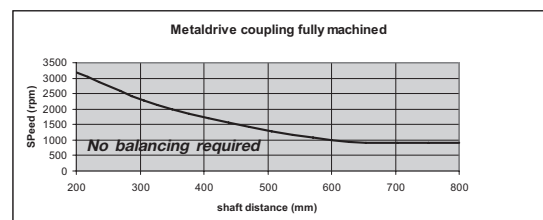
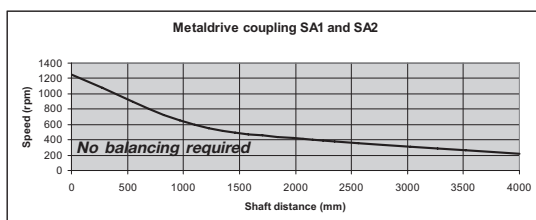

Working temperature

-40 °C + 225 °C

Misalignment

METALDRIVE couplings with double disc pack, allow axial, angular and radial misalignment.

METALDRIVE couplings with single disc pack allow only axial and angular misalignment.

Please note that application must not have the maximum value of axial and angular misalignment at the same time.

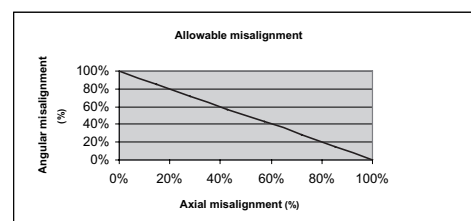

METALDRIVE GMD type S

Characteristics

Standard version with single disc pack. The coupling allows axial and angular misalignment. No radial misalignment is allowed.

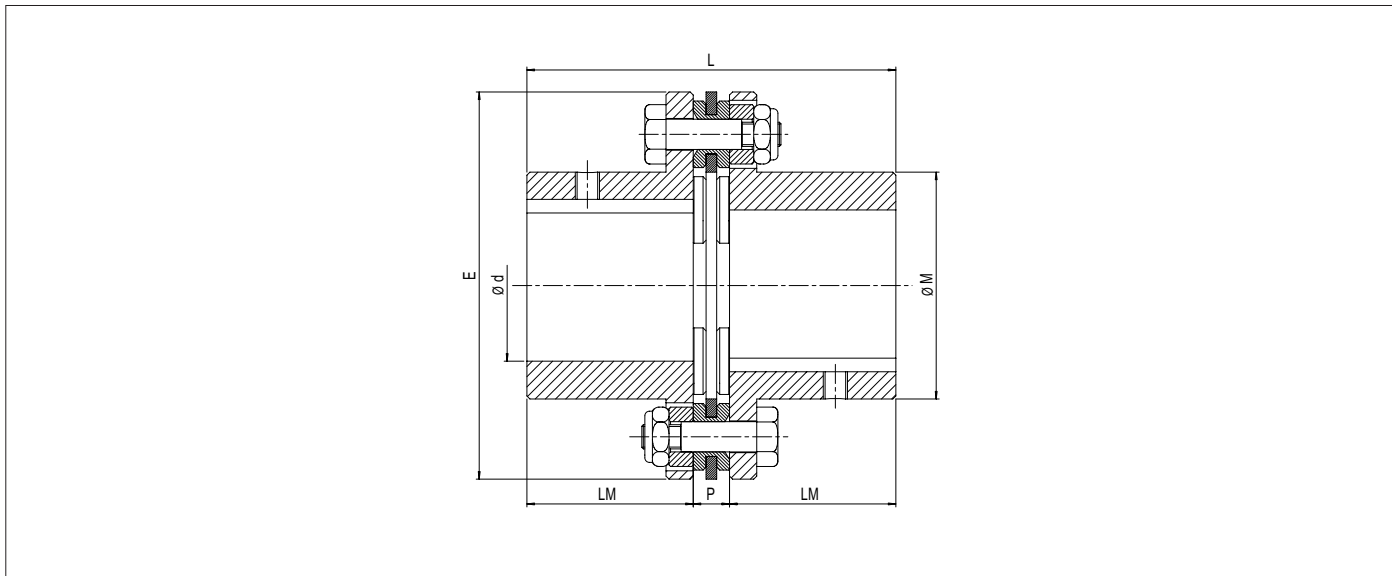

Size	Dimensions (mm)						Screws		
	Ø d max	Ø E	Ø M	LM	P	L	n°	Type	Tightening torque TA (Nm)
32	32	80	45	40	8	88	6	M5	8,5
38	38	92	53	45	8	98	6	M5	8,5
45	45	112	64	45	10	100	6	M6	14
52	52	136	75	55	12	122	6	M8	35
65	65	162	92	65	13	143	6	M10	69
80	80	182	112	80	14	174	6	M10	69
90	90	206	130	80	15	175	6	M12	120
95	95	226	135	90	22	202	6	M14	190
110	110	252	155	100	25	225	6	M16	295
120	120	296	170	110	28	248	6	M24	1000
138	138	318	195	140	32	312	6	M24	1000
155	155	352	218	150	34	334	8	M24	1000
175	175	386	252	175	37	387	8	M27	1500
190	190	426	272	190	37	417	8	M30	2000
205	205	456	292	205	42	452	8	M33	2450

Item code examples:



METALDRIVE GMD type DC

Characteristics

Standard version with double disc pack and standard length spacer.

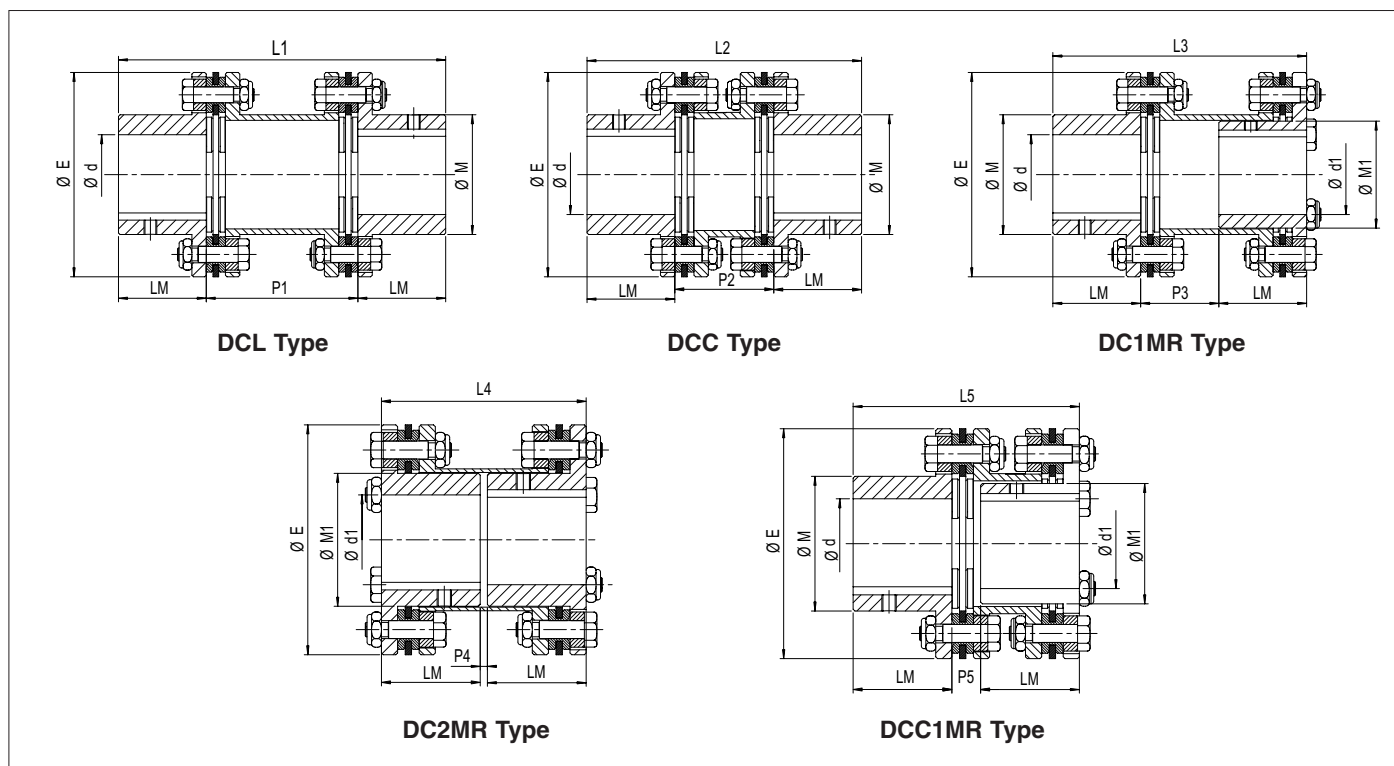

Size	Dimensions (mm)															
	Ød max	ØE	ØM	LM	DCL		DCC		ØM1	Ød1	DC1MR		DC2MR		DCC1MR	
					P1	L1	P2	L2			P3	L3	P4	L4	P5	L5
32	32	80	45	40	69	149	45	125	35	25	36	116	3	83	12	92
38	38	92	53	45	79	169	50	140	43	30	41	131	3	93	12	102
45	45	112	64	45	79	169	52	142	54	38	41	131	3	93	14	104
52	52	136	75	55	95	205	62	172	65	45	49	159	3	113	16	126
65	65	162	92	65	116	246	73	203	82	60	60	190	4	134	17	147
80	80	182	112	80	140	300	86	246	99	70	72	232	4	164	18	178
90	90	206	130	80	142	302	87	247	114	80	74	234	6	166	19	179
95	95	226	135	90	160	340	103	283	119	85	83	263	6	186	26	206
110	110	252	155	100	176	376	114	314	135	95	91	291	6	206	29	229
120	120	296	170	110	194	414	127	347	150	105	100	320	6	226	33	253
138	138	318	195	140	248	528	157	437	170	125	128	408	8	288	37	317
155	155	352	218	150	264	564	167	467	180	130	136	436	8	308	39	339
175	175	386	252	175	306	656	191	541	210	150	158	508	10	360	43	393
190	190	426	272	190	330	710	203	583	230	170	170	550	10	390	43	423
205	205	456	292	205	356	766	220	630	235	175	184	594	12	422	48	458

Item code examples:

METALDRIVE coupling
 Type
 Coupling size
 1st Hub bore (mm)
 2nd Hub bore (mm)

GMD DCL 45 F25 F30

METALDRIVE GMD type SA1

Characteristics

Shaft version. The shaft is of variable length and can be delivered in welded aluminium or steel

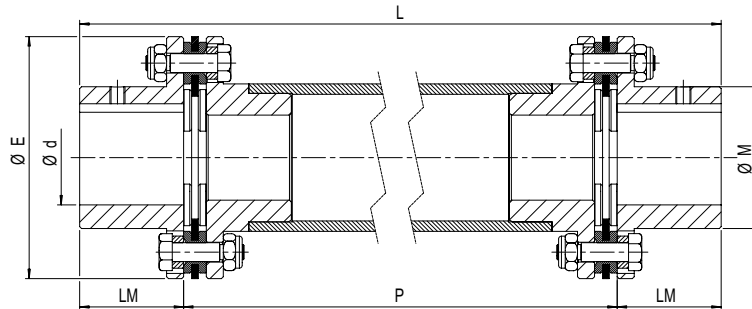

Size	Dimensions (mm)						
	Ød max	ØE	ØM	LM	SA1		
					P	L	
32	32	80	45	40	Shaft length on request	P+	80
38	38	92	53	45		P+	90
45	45	112	64	45		P+	90
52	52	136	75	55		P+	110
65	65	162	92	65		P+	130
80	80	182	112	80		P+	160
90	90	206	130	80		P+	160
95	95	226	135	90		P+	180
110	110	252	155	100		P+	200
120	120	296	170	110		P+	220
138	138	318	195	140		P+	280
155	155	352	218	150		P+	300
175	175	386	252	175		P+	350
190	190	426	272	190		P+	380
205	205	456	292	205		P+	410

Item code examples:

GMD	SA1	52	F20	F30	P2000	METALDRIVE coupling Type Coupling size 1 st Hub bore (mm) 2 nd Hub bore (mm) Distance between shaft ends (mm)
-----	-----	----	-----	-----	-------	----------------------------------------------------------------------------------------------------------------------------------------------------

METALDRIVE GMD type SA2

Characteristics

Shaft version with solid shaft construction. Variable shaft lengths are available.

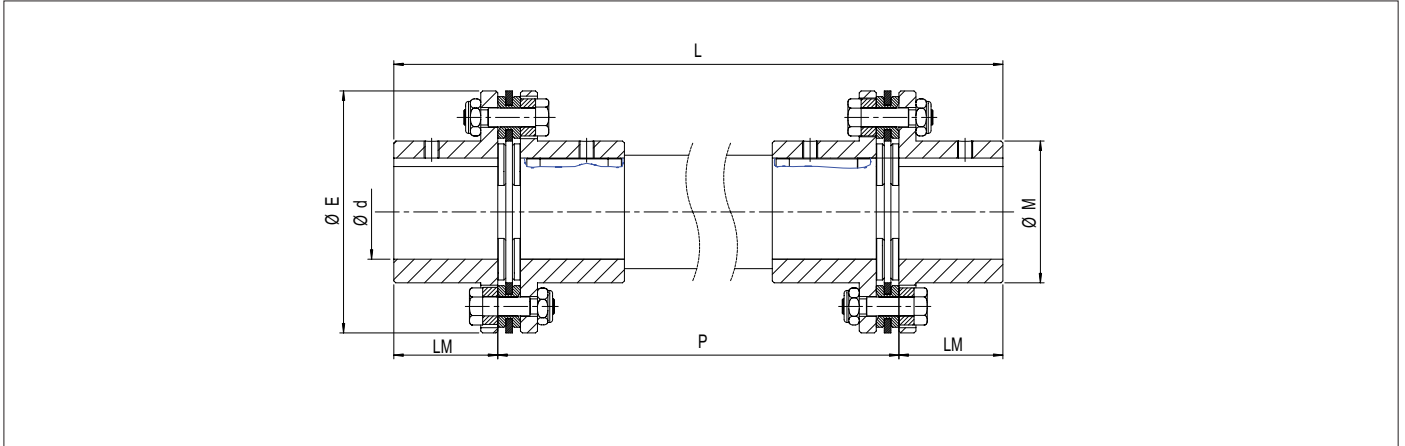

Size	Dimensions (mm)						
	Ød max	ØE	ØM	LM	SA2		
					P	L	
32	32	80	45	40	Shaft length on request	P+	80
38	38	92	53	45		P+	90
45	45	112	64	45		P+	90
52	52	136	75	55		P+	110
65	65	162	92	65		P+	130
80	80	182	112	80		P+	160
90	90	206	130	80		P+	160
95	95	226	135	90		P+	180
110	110	252	155	100		P+	200
120	120	296	170	110		P+	220
138	138	318	195	140		P+	280
155	155	352	218	150		P+	300
175	175	386	252	175		P+	350
190	190	426	272	190		P+	380
205	205	456	292	205		P+	410

Item code examples:

GMD **SA2** **80** **F30** **F40** **P1800**

METALDRIVE coupling
 Type
 Coupling size
 1st Hub bore (mm)
 2nd Hub bore (mm)
 Distance between shaft ends (mm)

METALDRIVE GMD type DCA (API671-API610)

Characteristics

Standard version with double disc pack and standard length spacer. Double disc pack execution with anti-fail device. Various spacer lengths available for pump applications. Conforms to API610-API671.

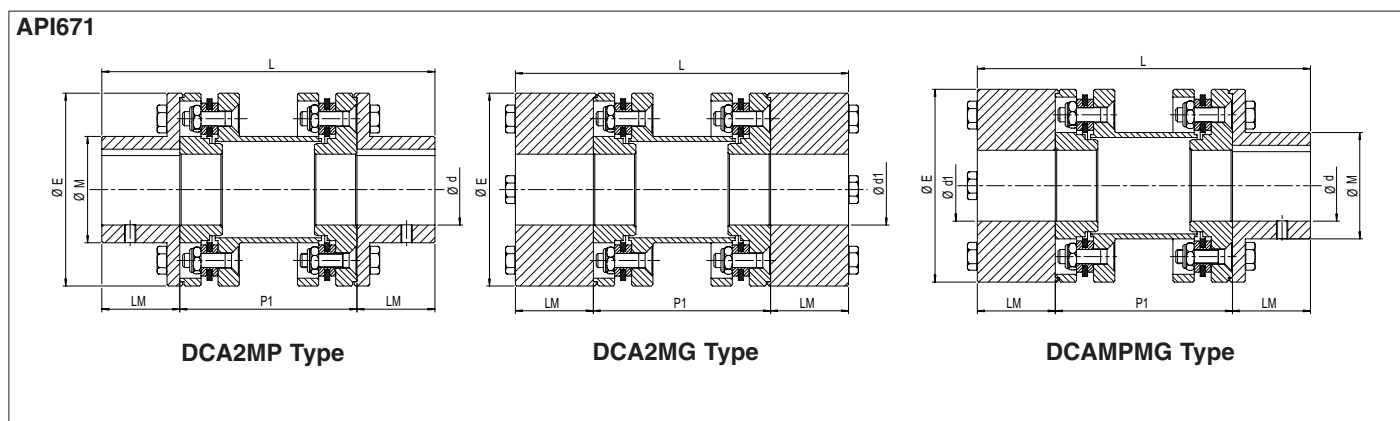

Size	Dimensions (mm)								
	øE	øM	LM	P1	L	DCA2MP	DCA2MG	DCAMPMG	
						Ød max	Ød1 max	Ød1 max	Ød1 max
35	80	50	40	69	149	35	48	35	48
42	92	60	45	79	169	42	55	42	55
52	112	74	45	79	169	52	75	52	75
68	136	96	55	95	205	68	92	68	92
82	162	115	65	116	246	82	105	82	105
95	182	134	80	140	300	95	120	95	120
110	206	154	80	142	302	110	135	110	135
118	226	165	90	160	340	118	—	—	—
125	252	175	100	176	376	125	—	—	—
140	296	198	110	194	414	140	—	—	—
155	318	225	140	248	528	155	—	—	—
180	352	255	150	264	564	180	—	—	—
190	386	270	175	306	656	190	—	—	—
205	426	290	190	330	710	205	—	—	—
230	456	325	205	356	766	230	—	—	—

Item code examples: (specify norm to respect)

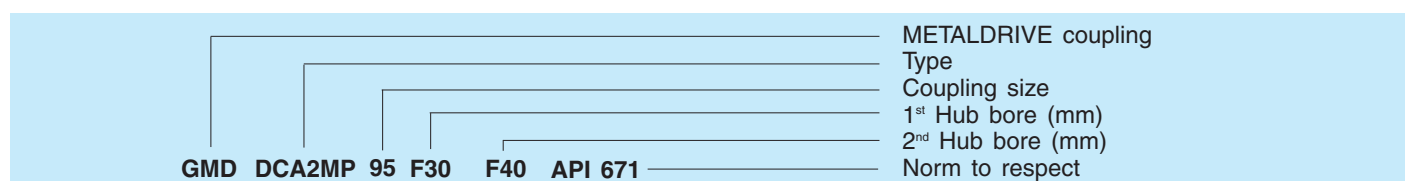

Hub-shaft connections

●●●● Keyway hub

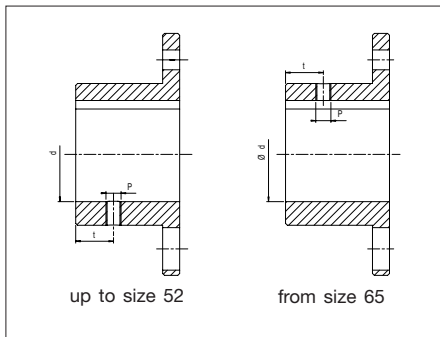

Size	Ød max	P	t	Set screw tightening torque T _A (Nm)
32	32	M6	15	4,8
38	38	M6	15	4,8
45	45	M8	20	10
52	52	M8	20	10
65	65	M8	20	10
80	80	M10	20	17
90	90	M12	25	40
95	95	M12	30	40
110	110	M12	30	40
120	120	M12	30	40
138	138	on request		
155	155			
175	175			
190	190			
205	205			

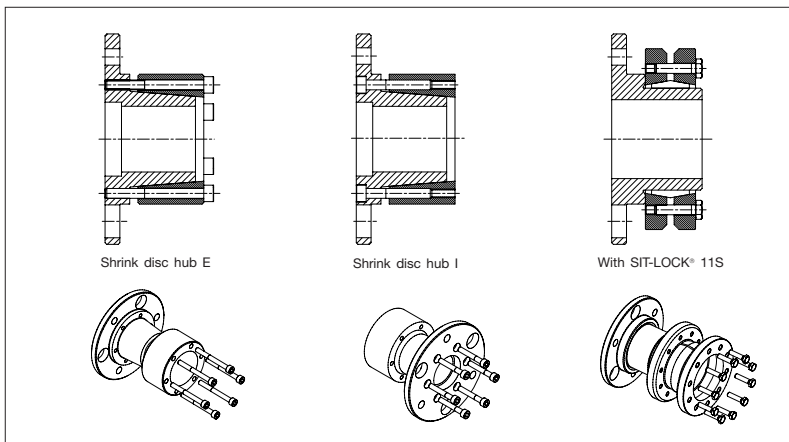

Shrink disc executions ●●●●

●●●● Split collar design

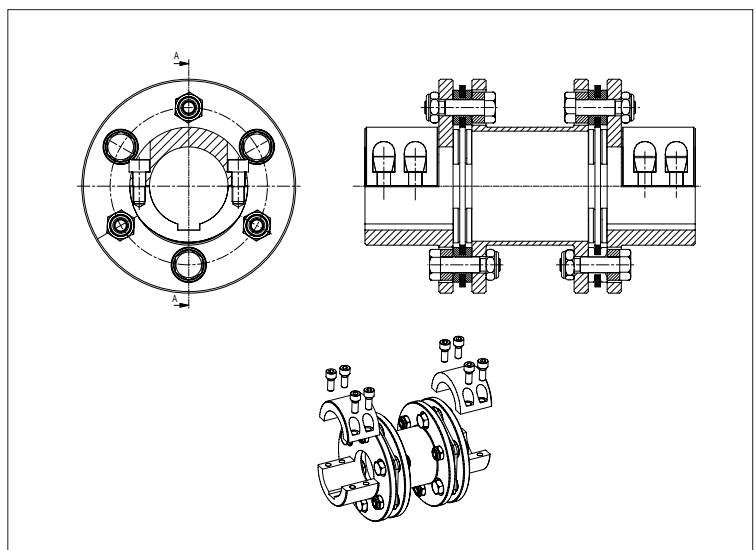

Selection procedure

Definitions

T_{Kmax} = peak torque capacity for a maximum of 10^5 times (Nm)

T_{Kn} = torque transmissible by the coupling at the maximum RPM with the allowable misalignments (Nm)

T_{KW} = maximum torque variation allowable by the coupling from the nominal torque T_{Kn} with a frequency of 10 Hz (Nm)

Coupling selection

- Calculate the nominal torque to be transmitted:

$$T_N = \frac{9550 \cdot P}{n}$$

T_N = nominal torque of the machine (Nm)

P = input power (kW)

n = RPM (1/min)

- Verify coupling nominal torque T_{Kn} :

$$T_{Kn} \geq T_N \cdot k$$

k = service factor

- Verify coupling maximum torque with machine peak and starting torque. It is allowed up to 5 peaks or start up/hour:

$$T_{Kmax} \geq T_s$$

T_s = starting or peak torque (Nm)

- In case of direct start with AC motor it is important to consider driver and driver inertias. In case of transmission with torque inversion, the maximum torque variation T_w should not be higher than the maximum coupling torque T_{kw} .

$$T_{kw} \geq T_w$$

- Verify working conditions.

Particularly maximum speed must not exceed the permissible value. Dynamic balancing (optional) allows higher speeds. Permissible speed could be limited by the weight and critical speed of spacers. Please consult with our technical department.

Service factor k and load classification

Compressors	
Piston compressors	H
Turbo compressors	M
Blowers, Ventilators	
Rotary piston blowers	M
Blowers (axial / radial)	U
Cooling tower fans	M
Turbo blowers	U
Pumps	
Centrifugal pumps (low viscosity liquid)	U
Centrifugal pumps (viscous liquid)	M
Piston pumps	H
Plunger pumps	H
Pressure pumps	H
Food industry machinery	
Bottling and container filling	U
Cane crushers, knives, mills	M
Bread machines	U
Packaging machines	U
Sugar beet machines	M
Chemical industry	
Agitators (liquid material)	U
Agitators (semi-liquid material)	M
Centrifuges (heavy)	M

Centrifuges (light)	U
Drums	M
Mixers	M
Building machinery	
Concrete mixers	M
Hoists	M
Road construction machinery	M
Generators, transformers	
Frequency transformers	H
Generators	M
Welding generators	M
Cranes	
Hoisting	U
Slewing	M
Travelling	H
Laundry machines	
Tumblers	M
Washing machines	M
Wood working machines	
Barkers	H
Planing machines	M
Saw frames	H
Wood working machines	U

Marble, clay and stones working machines	
Mills	H
Breakers	H
Brick presses	H
Ovens (rotary)	H
Metal rolling mills	
Cold rolling mills	H
Casting plants (continuous)	H
Heavy and medium plate mills	H
Manipulators	H
Roller tables (heavy)	H
Roller tables (light)	M
Sheet mills	H
Forging presses	H
Hammers	H
Machine tools, auxiliary drive	U
Machine tools, main drives	M
Metal planing machines	H
Plate straightening machine	H
Presses	H
Sheet metal bending machines	M

Driver machine	Driver machine load class		
	U	M	H
Electric motor, turbine, hydraulic motor	1,1	1,5	2
Piston engines with more than 3 cylindres	1,5	1,7	2,3
Piston engines up to 3 cylindres	1,7	2	2,6

U = uniform load

M = medium frequency peak load

H = high frequency peak load

METALDRIVE couplings weight and inertia

Size	Component										Complete coupling											
	Hub with max bore				Spacer GDM type DC				Disc pack		GDM type S hub with max bore		GDM type DCL hub with max bore		GDM type DCC hub with max bore		GDM type DC1MR hub with max bore		GDM type 2MR hub with max bore		GDM type DCC1MR hub with max bore	
	Hub M		Hub M1		Type P1		Type P2				Weight kg	Moment of inertia kg · m ²	Weight kg	Moment of inertia kg · m ²	Weight kg	Moment of inertia kg · m ²	Weight kg	Moment of inertia kg · m ²	Weight kg	Moment of inertia kg · m ²	Weight kg	Moment of inertia kg · m ²
	Weight kg	Moment of inertia kg · m ²	Weight kg	Moment of inertia kg · m ²	Weight kg	Moment of inertia kg · m ²	Weight kg	Moment of inertia kg · m ²	Weight kg	Moment of inertia kg · m ²	Weight kg	Moment of inertia kg · m ²	Weight kg	Moment of inertia kg · m ²	Weight kg	Moment of inertia kg · m ²	Weight kg	Moment of inertia kg · m ²	Weight kg	Moment of inertia kg · m ²	Weight kg	Moment of inertia kg · m ²
32	0,38	0,000253	0,32	0,00021	0,52	0,00042	0,42	0,00038	0,078	0,000034	0,8	0,0005	1,4	0,001	1,3	0,001	1,3	0,001	1,2	0,001	1,2	0,001
38	0,57	0,00049	0,5	0,0004	0,71	0,00081	0,58	0,0007	0,094	0,000109	1,2	0,0011	2	0,002	1,9	0,0019	1,9	0,0019	1,8	0,0018	1,8	0,0018
45	0,86	0,0011	0,76	0,00092	0,97	0,0016	0,82	0,0015	0,183	0,00031	1,9	0,0025	3,1	0,0044	3	0,0043	3	0,0042	2,9	0,004	2,9	0,0041
52	1,57	0,0029	1,22	0,0024	1,7	0,0044	1,5	0,0041	0,31	0,00076	3,5	0,0066	5,5	0,0117	5,3	0,0114	5,2	0,0112	4,9	0,0107	5	0,0109
65	2,5	0,0064	2,1	0,0055	2,4	0,009	2,1	0,0082	0,45	0,0015	5,5	0,0143	8,3	0,0248	8	0,024	7,9	0,0239	7,5	0,023	7,6	0,0231
80	4,3	0,0147	3,87	0,0126	4	0,02	3,4	0,018	0,56	0,0024	9,2	0,0318	13,7	0,0542	13,1	0,0522	13,3	0,0521	12,9	0,05	12,7	0,0501
90	5,9	0,026	5,1	0,021	5,4	0,033	4,4	0,03	0,75	0,0042	12,6	0,0562	18,7	0,0934	17,7	0,0904	17,9	0,0884	17,1	0,0834	16,9	0,0854
95	7,2	0,037	6,4	0,032	6,8	0,05	5,8	0,045	1,7	0,012	16,1	0,086	24,6	0,148	23,6	0,143	23,8	0,143	23	0,138	22,8	0,138
110	10,3	0,068	9,2	0,057	10	0,09	8,3	0,08	2,4	0,022	23	0,158	35,4	0,27	33,7	0,26	34,3	0,259	33,2	0,248	32,6	0,249
120	14,4	0,125	13,1	0,11	13,7	0,17	11,8	0,16	4,9	0,058	33,7	0,308	52,3	0,536	50,4	0,526	51	0,521	49,7	0,506	49,1	0,511
138	22,6	0,232	18,9	0,19	21,3	0,3	17,4	0,27	5,4	0,078	50,6	0,542	77,3	0,92	73,4	0,89	73,6	0,878	69,9	0,836	69,7	0,848
155	29,86	0,38	24,73	0,3	32,1	0,54	25	0,46	6,1	0,113	65,8	0,873	104	1,526	96,9	1,446	98,9	1,446	93,8	1,366	91,8	1,366
175	46,3	0,73	37,7	0,55	46,9	0,97	35,7	0,81	9,3	0,215	101,9	1,675	158,1	2,86	146,9	2,7	149,5	2,68	140,9	2,5	138,3	2,52
190	59,9	1,14	47,7	0,88	59,9	1,53	47	1,32	11	0,3	130,8	2,58	201,7	4,41	188,8	4,2	189,5	4,15	177,3	3,89	176,6	3,94
205	74	1,63	57	1,21	85	2,36	64	1,98	15,3	0,48	163,3	3,74	263,6	6,58	242,6	6,2	246,6	6,16	229,6	5,74	225,6	5,78

Note

Values for hubs refer to maximum bore execution. Values for disc packs include bolts.

● ● ● ● Disc pack executions

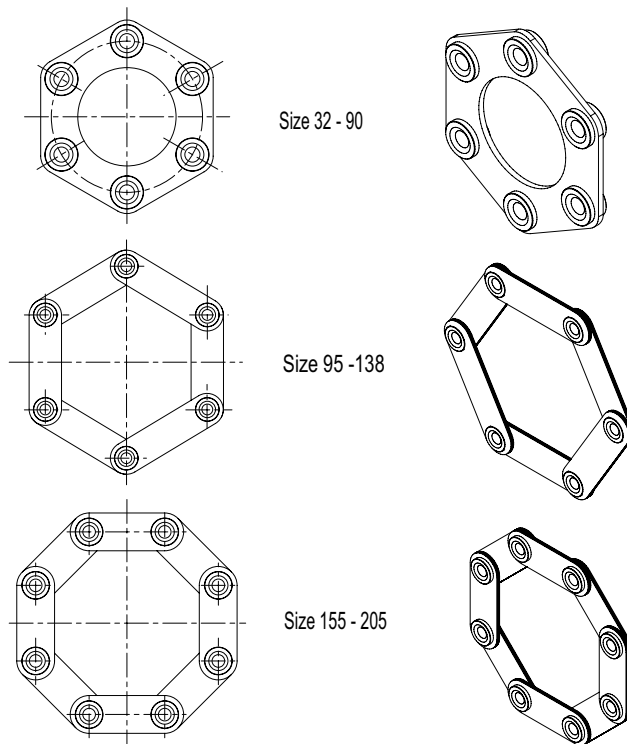

Mounting instructions

METALDRIVE couplings come standard unassembled (excepted if expressly required).

When mounting the coupling it is important to follow the specific recommendations.

Due to the modular design of the METALDRIVE coupling, single parts can be replaced. For optimum performance, all components must be in perfect conditions.

METALDRIVE couplings are designed for horizontal mounting. In case of vertical mounting the coupling weight must be supported.

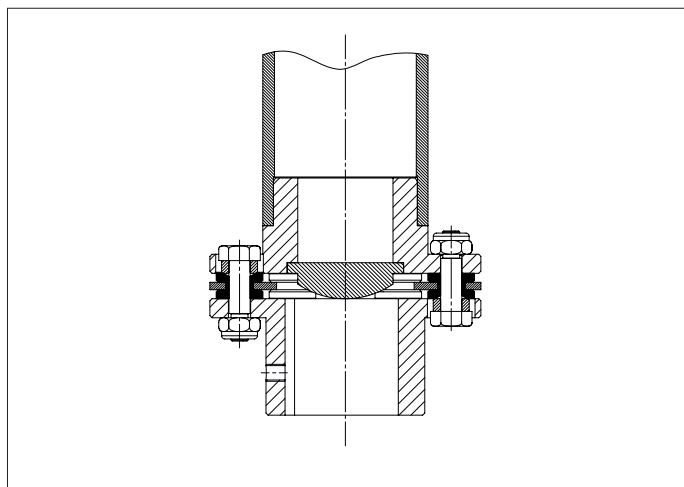

- Carefully clean bores, shaft ends and the flange where the screws are positioned.
- Position the hubs on the shafts of the machines. Hub faces must be flush with shaft end. Introduce setscrew and tighten properly.
- Position the driver and driven unit to be connected
- Carefully align the shafts to be connected. Proper initial alignment allows misalignments during motion and ensures transmission durability. It is therefore suggested to check shaft alignments with an indicator before the machine start up.
- Mount the disc pack with screws and nuts. Tighten to torque T_A holding the screws and turning the nuts.
- Install the spacer between the hubs and connect it to the already assembled disc pack with screws and nuts (in case of long spacer, it is important to support the spacer). Tighten to torque T_A holding the screws still and turning the nuts.
- Check once again shaft alignment

In case hubs are machined by the user, it is recommended to ask for correct concentricity and perpendicularity tolerances which could affect coupling life.

There is no need for lubrication.

Safety norms

All rotating parts must be protected against any possibility of contact with people

Protection must be designed so that even in case of coupling break, no damage can be done to people and equipment.

Type	T_A (Nm)
32	12
38	13
45	22
52	39
65	85
80	105
90	127
95	260
110	480
120	760
138	780
155	800
175	1100
190	1500
205	2600