

# Built-in Pumps & Accessories

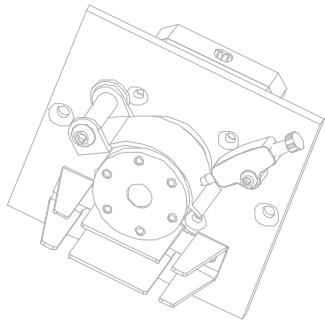

## OEM Versions

- Peristaltic pumps
- Symax syringe pumps
- Tubing

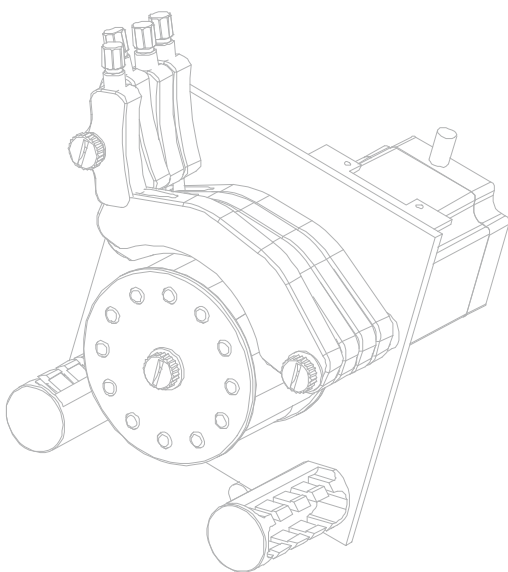
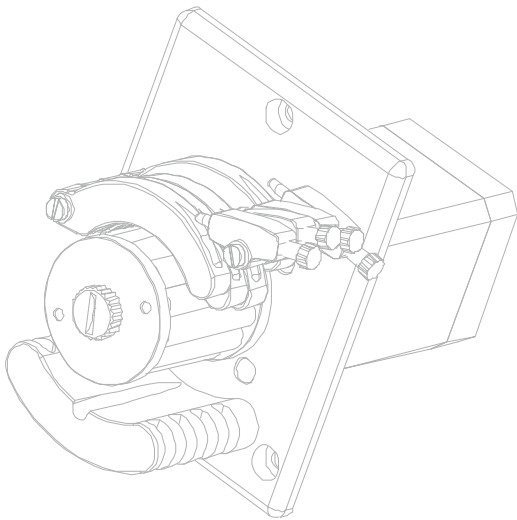

# Built-in OEM peristaltic pumps

The basic purpose of a peristaltic pump is to move fluids from A to B. But this is not enough for manufacturers of analysis equipment and other devices that require fluids to be transported.

Alongside technical characteristics such as pulsation, precision and stability, other factors also play a role, such as an attractive, individual appearance of the pumps.

And that is exactly what Spetec aims for.

## Content

	Page
Precision Standard .....	4
Precision Compact .....	5
Low-cost-mini .....	6
Stepper motor controller .....	7
Examples of built-in peristaltic pumps .....	8
Syringe pump Symax .....	10
Tubing .....	11

# Individuality is where our strength lies

Spetec does not offer traditional series. Instead, a few basic components and parts are used that are manufactured in large quantities for many customers. The visual appearance, on the other hand, is always designed to customer requirements. In essence, this concerns the color and form of the baseplate on which the actual pump is fitted. It is also possible to influence the color and shape of many other individual components.

The result is a custom product bearing the signature of the device's manufacturer and which perfectly matches the design of the overall unit.

A number of key benefits are brought together:

- **Low costs**
- **Simple installation during final assembly of the devices**
- **Individuality**



To help you make the right decisions as you put together your custom product, our peristaltic pumps are grouped into three categories on the following pages:



# Precision Standard



The large roller head with 12 rollers allows these pumps to meet the most stringent requirements in respect of low pulsation and consistency of fluid delivery.

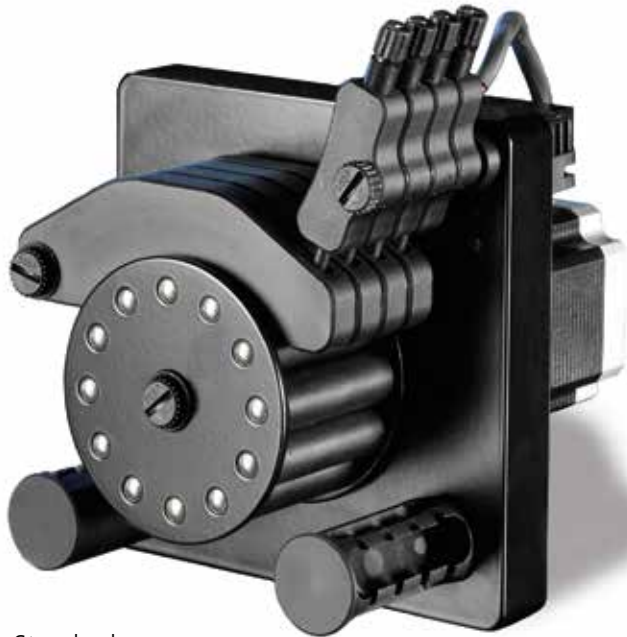

Precision Standard  
Exemplary illustration

## Technical data

Mechanical:	Roller head 72 mm
Number of channels	1 – 6
Speed	0 – 80 rpm
Drive	Stepper motor without gearing, wear-free
Stepper motor	1.8°
Intermediate shaft	Mounted on 2 ball bearings
All parts	Either made from PVC, PP or powder-coated
Dosing range	
Each channel	0 to 45 ml/min

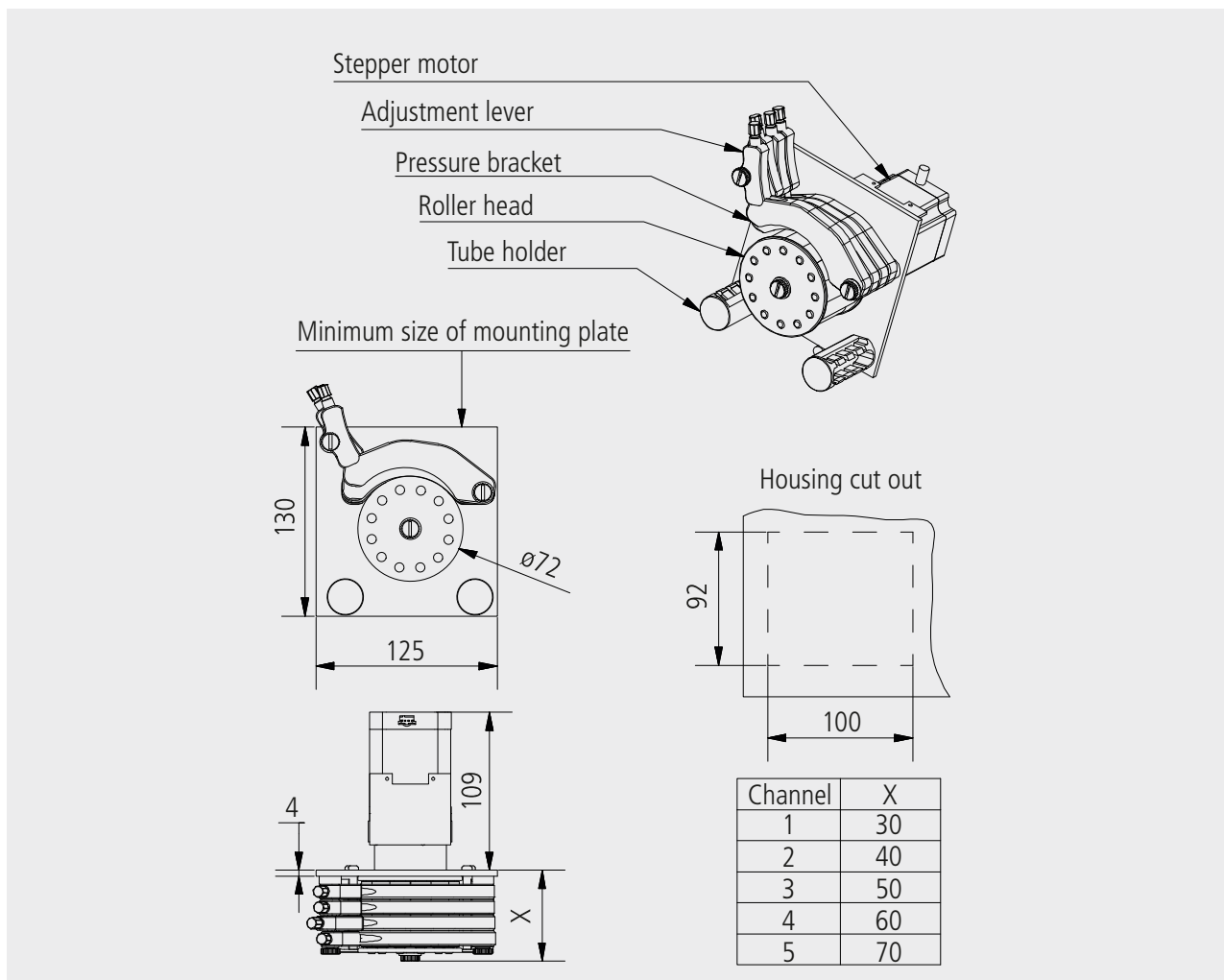

# Precision Compact

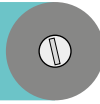

This is a smaller version of the standard pump with a scale of 2:1. It has extremely similar properties in respect of delivery accuracy.



Precision Compact  
Exemplary illustration

## Technical data

Mechanical:	Roller head 36 mm
Number of channels	1 – 4
Speed	0 – 100 rpm
Drive	Stepper motor without gearing, wear-free
Stepper motor	1.8°
Intermediate shaft	Mounted on 2 ball bearings
All parts	Either made from PVC, PP or powder-coated
Dosing range	
Each channel	0 to 8,5 ml/min

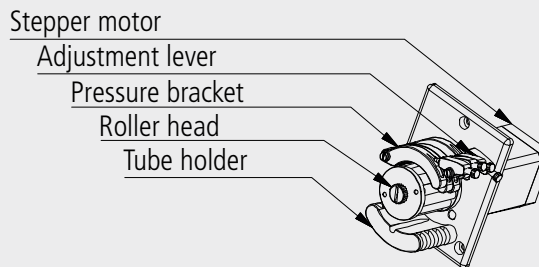

Minimum size of mounting plate

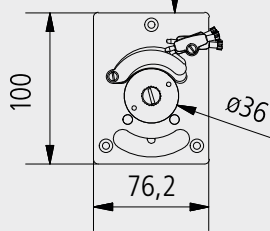

Housing cut out

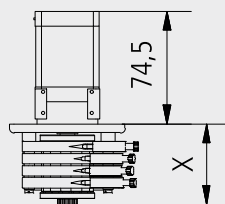
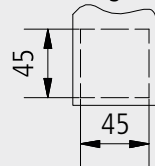

Channel	X
1	30
2	38
3	46
4	54
5	62

# Low-cost-mini



These pumps are simpler, less expensive versions that are also operated with wear-resistant stepper motors.

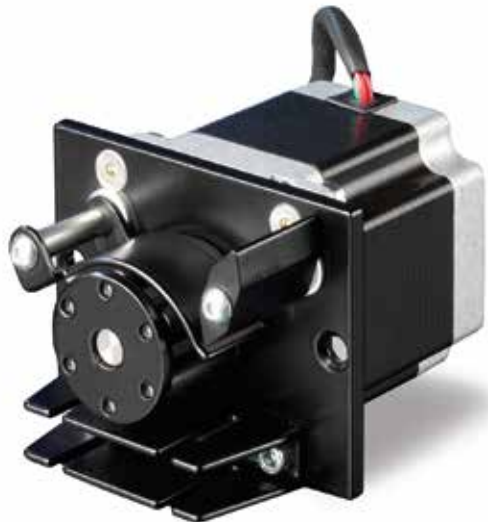

Low-cost-mini  
Exemplary illustration

## Technical data

Mechanical: Roller head 30 mm	
Number of channels	3
Speed	0 – 100 rpm
Drive	Stepper motor without gearing, wear-free
Stepper motor	1.8°
Intermediate shaft	Mounted on 2 ball bearings
All parts	Either made from PVC, PP or powder-coated
Dosing range	
Each channel	0 to 23 ml/min

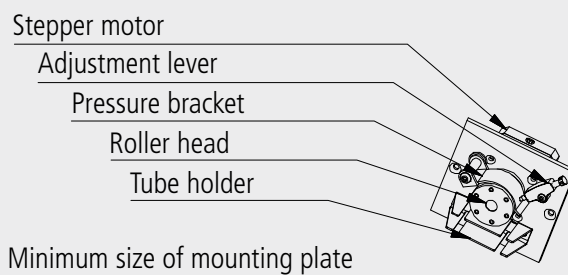

Minimum size of mounting plate

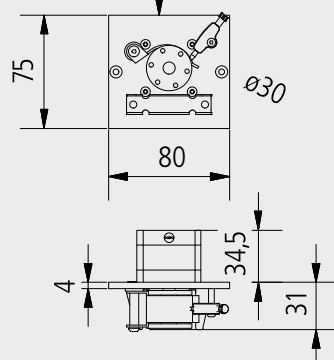

Housing cut out

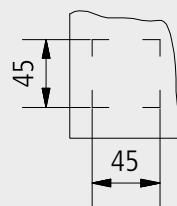

# Stepper motor controller SM04



The optionally available Spetec stepper motor controller SM04 is an in-house development that can be fixed directly to the pump. It has been designed for the operation of 2-phase stepper motors with step angles of  $1.8^\circ$  and  $0.9^\circ$ . Using the Spetec SM04, a single full step can be subdivided into 64 microsteps. This corresponds to 12,800 steps per revolution. This ensures that the equipment runs extremely smoothly and silently.

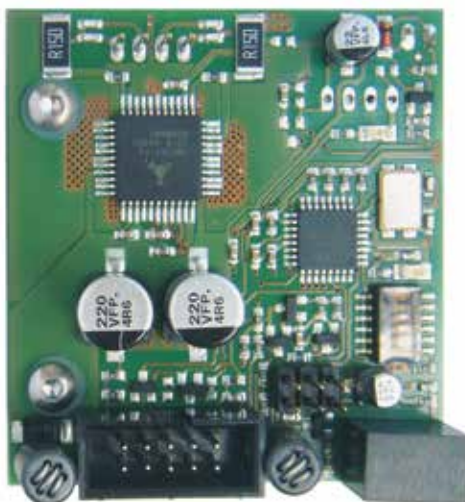

## Benefits

- On-chip temperature monitoring
- Reduced current at low speeds, resulting in less heating of stepper motor
- Simple control via analog input
- Quieter running through 1/64 microstep control
- Board can be operated without ventilation
- Compact assembly at installed pump

## Technical data

Stepper motor controller SM04 (optional)	
Control board	Optional
Supply voltage	24V
Power supply	1.65A max.
Input for operating speed	0 – 5V , analog
Corresponds to	0 – 100 rpm
Speed range	Optionally selectable via DIP switch
Input for enable	TTL signal
Input for reverse rotation	TTL signal
Input for high speed	TTL signal



# Examples of built-in peristaltic pumps



Diameter roller head: 36 mm



Diameter roller head: 30 mm



Diameter roller head: 72 mm

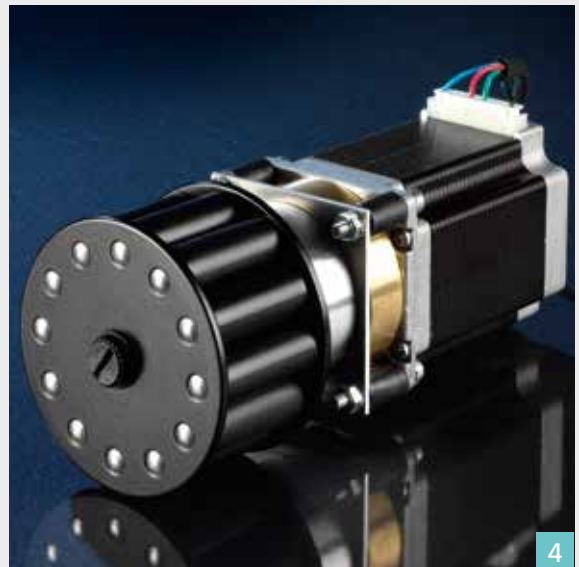

Diameter roller head: 72 mm



Diameter roller head: 72 mm

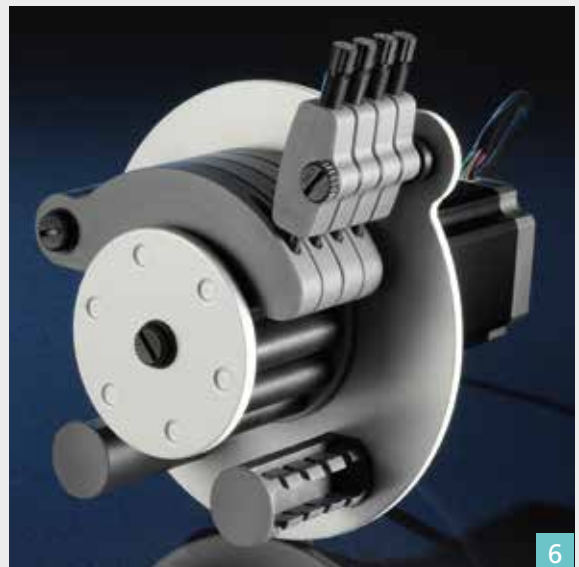

Diameter roller head: 72 mm



**Precision Standard** 3 4 5 6 7 9 11 12  
**Precision Compact** 1 8  
**Low-cost-mini** 2 **Special edition** 10

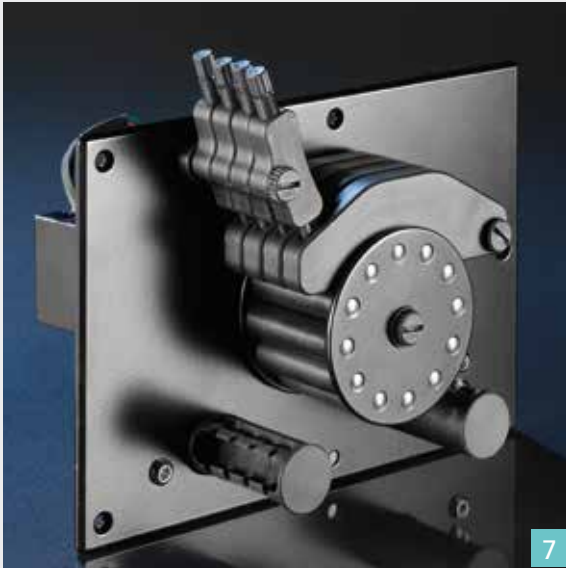

Diameter roller head: 72 mm



Diameter roller head: 36 mm



Diameter roller head: 72 mm



Diameter roller head: 30 mm

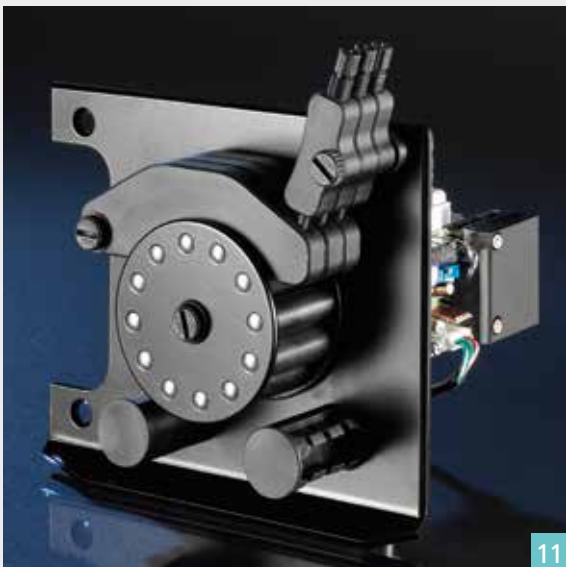

Diameter roller head: 72 mm

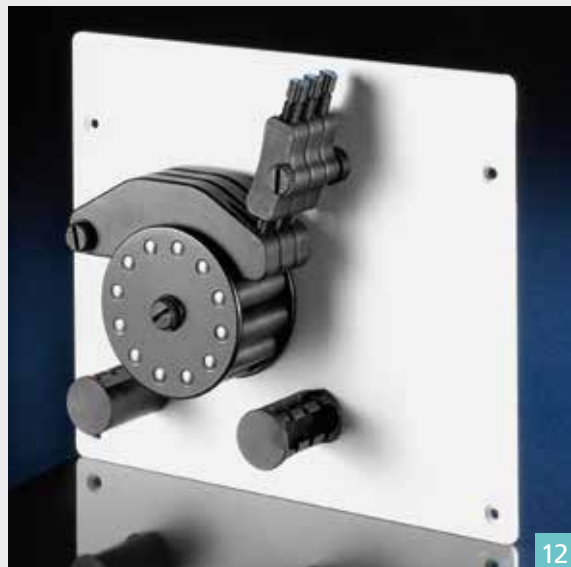

Diameter roller head: 72 mm

# Syringe pump

## SYMAX

The Spetec syringe pump is used for metering fluids in the microliter and nanoliter range. Its core components consist of the stepper motor drive with no wear components such as clutch or gearing, high-precision carriage, syringe holder set, and replaceable syringe. Thanks to the high resolution of 25,600 steps per revolution, individual steps during the movement sequence are barely perceptible.

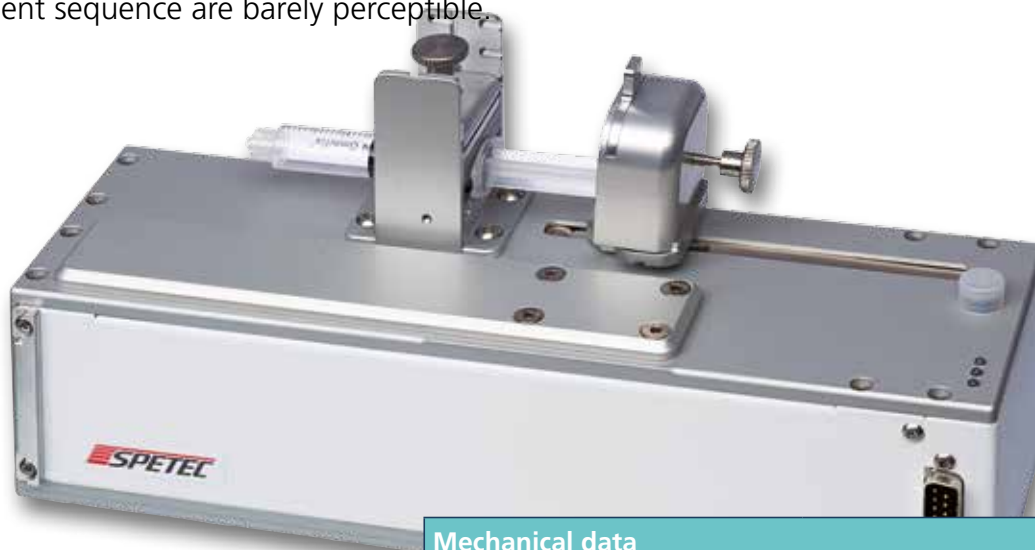

### Technical data SYMAX



[www.spetec.de/en/products/laboratory-equipment/syringe-pump-symax](http://www.spetec.de/en/products/laboratory-equipment/syringe-pump-symax)

**Request our  
seperate brochure.**

Mechanical data	
Dimensions LxWxH (without syringe holder)	270 x 95 x 85 (mm)
Weight	2,100 g
Maximum stroke	91.5 mm
Minimum feed rate	0.248 nm/s
Maximum feed rate	1.24 mm/s
Smallest step resolution	0.0248 µm
Accuracy	+/- 2%
Reproducibility	+/- 2%
Transverse force	100N at 0.0254 mm/s
Extendable	Up to six individually controllable channels per group; two groups can be operated from one PC
Materials	Anodized aluminum Powder-coated stainless steel Viton® (support for syringes)
Adjustable syringe holder	Permitted syringe diameters from 9 mm to 34 mm
Electrical data	
Power supply	Input 100–240V / 50–60 Hz Output: 24V / 2,5A
Power consumption per pump	Standby current: 210 mA Operating current: 420 mA
Data interfaces	RS 485 / USB
LabView	LLB ready for integration in user's own system
Operating conditions	
Temperature range	+10 to +40°C
Relative humidity	20 % to 80 %, non-condensing
Suitable media	aqueous, acidic and alkaline media

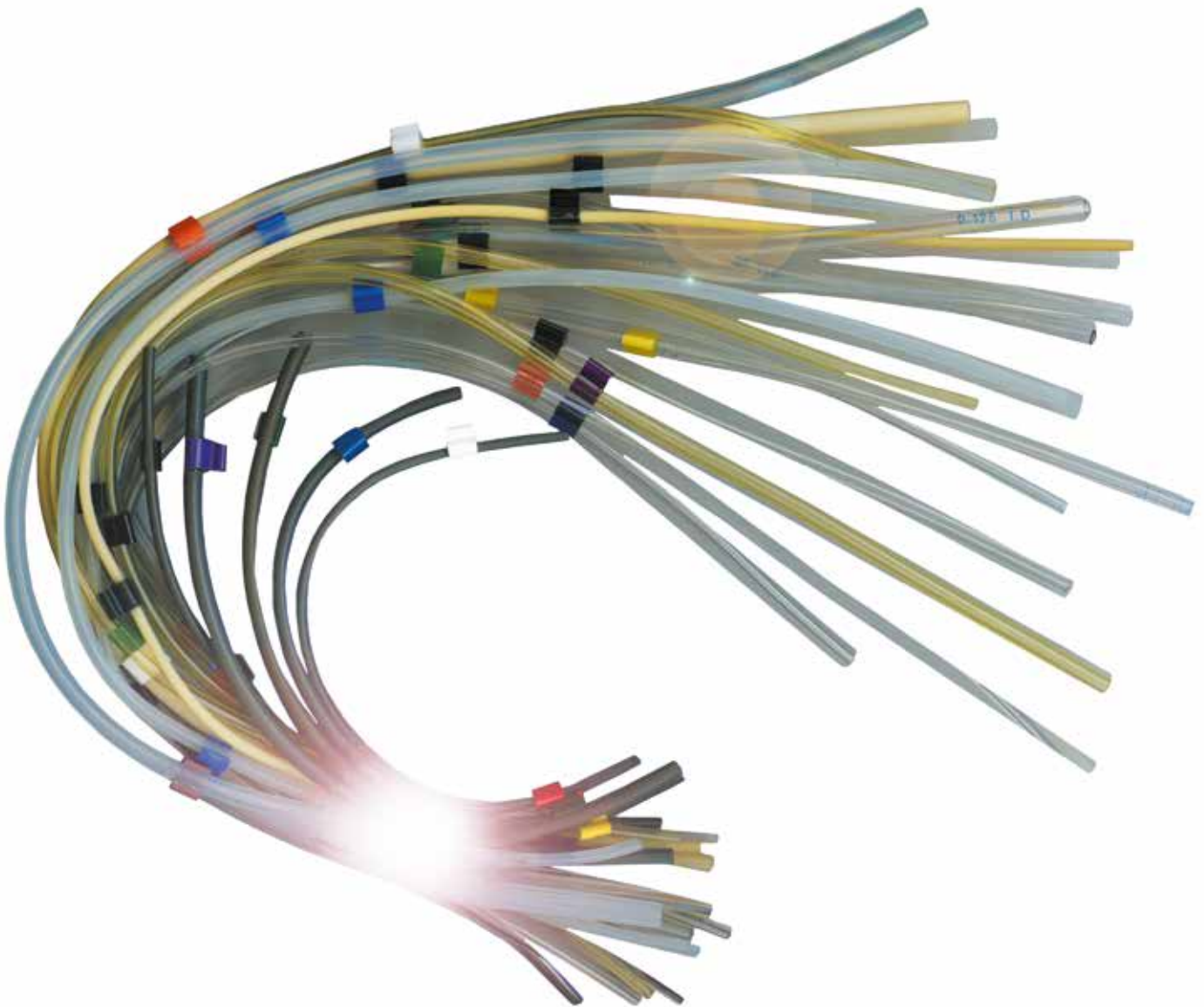

Variety is where our strength lies. We can supply you with any tubing configuration in a range of diameters and grades with 1, 2 or 3 bridges. Alternatively, we can supply tubing by the meter. Do you need special lengths with unusual bridge intervals? We would be happy to send you an offer with short delivery times.

- Materials:**
- PVC Standard
  - Solvent Flex – Solvent resistant
  - PU Longlife
  - Fluoro rubber (comparable to Viton)
  - Santoprene®  
(comparable to Pharmed/Mediprene)
  - Silicone



[www.spetec.de/en/products/laboratory-equipment/pump-tubing-tubes](http://www.spetec.de/en/products/laboratory-equipment/pump-tubing-tubes)

**Request our  
seperate brochure.**

SPETEC® GmbH  
Berghamer Str. 2  
D-85435 Erding

Phone: +49 (0)8122/99533  
Fax: +49 (0)8122/10397

E-mail: [spetec@spetec.de](mailto:spetec@spetec.de)  
[www.spetec.de](http://www.spetec.de)

