

惠科达

Vacorda

Customer satisfaction is our eternal pursuit

Metal Tube Flowmeter



Vacorda Instruments Manufacturing CO., LTD

Address: No. 486, 3rd East of Guanghua Road,
Qingyang District, Chengdu City, Sichuan, China

Tel: 86-28-87013699 Fax: 86-28-87362258

E-mail: nancy@vacorda.com

Http://www.vacorda.com

Part One: Introduction

Metal tube flowmeter consists of measuring tube, float, indicator and process connection components with the characteristics of small size, wide measuring range, and easy installation. In the industry area, it is widely used to measure flow of gas, liquid, and steam, especially suitable for mediums with low current velocity and low flow rate.

There are local indicators and smart remote types. For the local type, needles pointer shows instant flow. For the LCD type, needles pointer shows instant flow. The instant flow and the accumulative flow are digitally shown on the LCD display. For the smart remote type, there are many kinds of outputs, such as upper-lower limit alarming output, pulse output, standard two-wire 4-20mA current output, and HART communication protocol and so on.

Smart remote metal tube flowmeter adopts advanced 16-bit microprocessor, high accuracy sensor, SMD elements and high quality industrial components to guarantee the excellent performances of this flowmeter after the signal processing technology of digital filtering and software calibration.

According to different process connection methods, metal tube flowmeters are divided into many inflow-outflow types, such as bottom inflow& top outflow type, left inflow&right outflow, right inflow&left outflow and so on. Customer can choose the measuring tube needed according to its requirements. Due to its excellent performance, reliability and competitive price, it is widely used in the fields of oil, chemical industry, steel manufacture, light industrial, water etc. Metal tube flowmeter takes many different materials and is suitable for flow measurement of all non-corrosive, corrosive and strong corrosive mediums.

Part Two: Features

- 1.Single axle, smart display, high reliability, easy maintenance, long life time.
- 2.Flow ratio:10:1, special type: 20:1. Less requirement on the straight tube.
- 3.Suitable for small size type and low flow rate fluids.
- 4.Metal structure, suitable for strong corrosive mediums and environments with non-contacting magnetic coupling transmission.
- 5.LCD display, showing instant flow and total flow at same time. High temperature, high pressure and flammable and explosive conditions.
- 6.Design with two watchers, strongly anti-interference CPU and additional circuit to make goods woke stably.
- 7.With function of upper-lower limit alarm, two-wire system to isolate switch output.
8. Compatible with HART.
- 9.Local display and remote display available, also AC power, DC power and battery can be provided.



Part Three: Working principle

Measured medium flows through the space between measuring tap pipe and float from bottom to top, producing differential pressure on the top and bottom of float to form lifting force. When the lifting force on float is stronger than the weight of float in the fluid, the float will rise, annular area will also increase, the flow rate of fluid at annular space will suddenly decrease, the differential pressure on top and bottom of float decreases, the lifting force on the float also decrease till lifting force and the weight of float keep balance, float will stay at a location. The height of float is the flow of measured medium. There's magnetic steel in the float, while float moves up and down with medium, magnetic field will change with the movement of float. The matchup of float's flow between the float in the tap pipe and the flow passing annular space:



$$Q = \alpha \varepsilon \Delta F \sqrt{\frac{2gV_f(\rho_f - \rho)}{\rho F_f}} m^3 / s$$

When float is not hollow, then

$$Q = \alpha \varepsilon \Delta F \sqrt{\frac{2g(G_f - V_f \rho)}{\rho F_f}} m^3/s \quad (2)$$

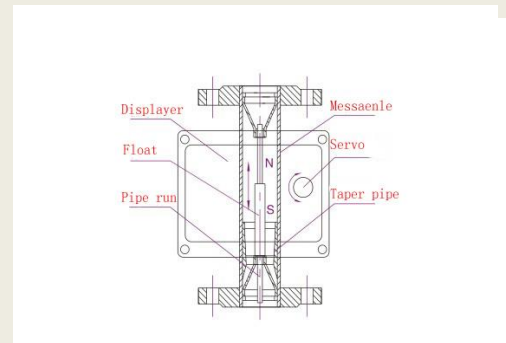

In the formula:

- α — flow factor
- ε — expansion index of gas when measured medium is gas
- ΔF — Circulation annular area (m^2)
- g — Local acceleration of gravity (m/s^2)
- V_f — Volume of float (m^3)
- ρ_f — Density of float (kg/m^3)
- ρ — Density of measured medium (kg/m^3)
- F_f — Transverse area of float's diameter (m^2)
- G_f — Weight of float (kg)

The relation between circulation annular area and the height of the float is: $\Delta F = \pi \left(d h \tan \frac{\beta}{2} + h^2 \tan^2 \frac{\beta}{2} \right) = ah + bh^2$

In the formula: h — Lifting height of the float, when inner diameter of taper pipe equals to the max diameter of float.

- β — Cone angle of taper pipe
- a, b — Constant

a. Local type, coupled by servo magnetic steel in the local indicator and inner magnetic steel of float, to produce turning, and drive the pointer. Indicating the flow by dial. (As the sketch)

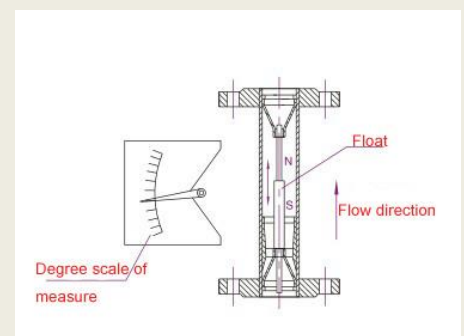

b. Intelligent remote type, coupled by servo magnetic steel in the intelligent indicator and inner magnetic steel of float, to produce turning, and drive the transmitting magnetic steel and pointer. Transforming the change of magnetic field into signal by magnetic sensor, via A/D conversion, digital filtering, temperature compensation, microprocessor process, D/A output, LCD displayer, to display instant flow and accumulated flow. (As the sketch)

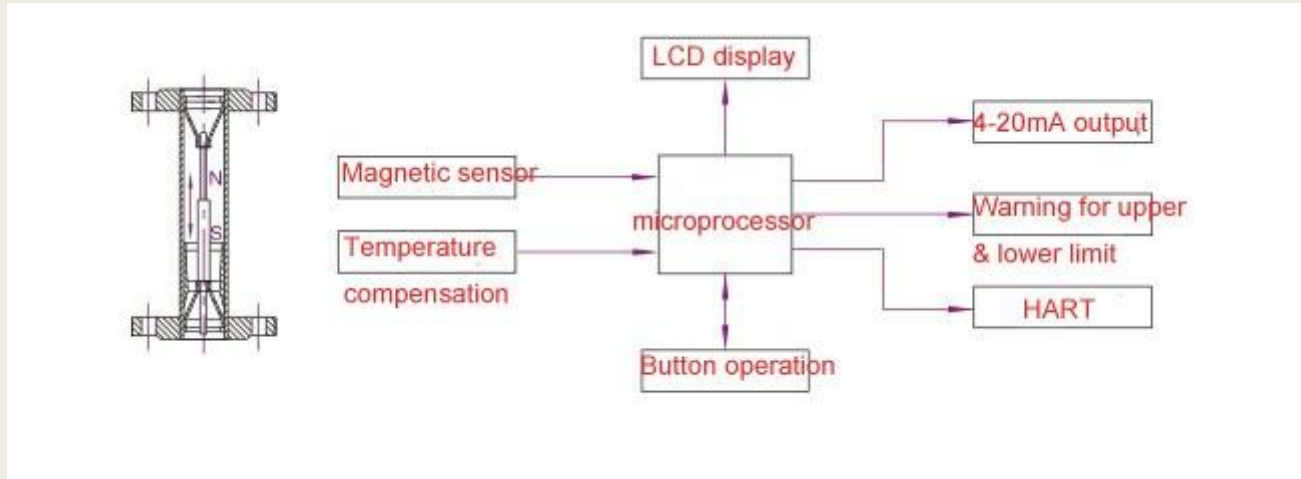

Part Four: Technical parameters

Measuring range	Water:1-150000L/H(20°C)
	Air: 0.7~3000m ³ /h (20°C, 0.1013MPa)
Measuring range proportion	Standard: 10:1
Accuracy class	Standard:1.5, 2.5; Special: 1.0
Pressure rating	Standard & sanitary one:DN15~DN50≤4.0MPa; DN80~DN200≤2.5MPa
	Special one:DN15~DN25≤42MPa;DN50~DN100≤16MPa
	Jacket one: 1.6MPa
Pressure loss	7kPa~70kPa
Medium temperature	Standard:-70°C~+180°C; PTFE:-50°C~+100°C(Change frequently is not allowed)
	High pressure:350°C
Medium viscosity	DN15:η<5mPa.s(F15.1~F15.3), η<30mPa.s(F15.4~F15.8)
	DN25:η<250mPa.s; DN50~DN200:η<300mPa.s
Environment temperature	Remote type: -40°C~+85°C (LCD display: -35°C~+70°C)
	Local needle indicator: -40°C~+100°C

Connection type	Flange; Sanitary tri-clamp
Jacket connection	DN15/PN1.6MPa or 1/2" ANSI 150LB RF or ϕ 12mm tube
Flange Standard	Standard: GB/T 9119-2010, HG20592, ASME/ANSI B 16.5, DIN2501, SH3406
	Food type: SMS, DIN 11851, Tri-clamp
Wiring connection	M20×1.5; 1/2NPT female thread
Power supply	Standard: 24VDC two-line 4~20mA(12VDC~32VDC)
	AC type:85~260VAC
	Battery type:3.6V lithium battery(2-3 years lifetime)
Loading resistance feature	Two-line: max loading resistance 500 Ω (24VDC)
	Multi-line: max loading resistance 500 Ω
Warning signal output	Reed pipe warning switch output, upper limit and lower limit flow warning(contact capacity 250V 0.05A or 24VDC 0.2A)
LCD display	Instant flow display scope:0~99999
	Total flow display scope: 0~99999999
Protection grade	IP65, IP67
Explosion-proof grade	Exia II CT6Ga Exd II BT6Gb
Installation Height:	Standard height: 250mm for DN15-DN200; High pressure type: 300mm for size > DN80

Part Five: Model introduction

Our company provide three kinds of indicator for customer choice (M1, M2,M3). M1 and M3A are mechanical needle pointer, suitable for local display; M2 is remote type with LCD indicator and can used for Exia II CT5Ga application. M3 is digital display and used for Exia and Exd application.

1. M1, M3A mechanical needle indicator

M1 is square shell structure & M3A is round housing. They use float in the pipe to let needles moving by magnetic steel moving, thus to get the flow from scale. Its characteristic is simple structure, reliable and no need power supply.



M1 Type



M3A Type



M2 Type



M3 Type

2.M2 Exia indicator

M2 is square housing structure, Exia II CT5Ga design. This type is mechanical needle display to show instant flow, 5 digit LCD displaying Instant flow, 8 digit LCD display total flow, also output 4~20mA signal, upper limit and lower limit warning signal.

M2 indicator provides 2 NO alarm contacts, with capacity 400V 0.05A or 24VDC 0.2A. It can be set by the screen panel.

3. M3 Exd indicator

M3 is a round housing, designed with Exia II CT6GB and Exd IICT6Gb. Its function covers all of M1 and M2. It has needle pointer system, which can replace M1 and M2 indicators.

M3 has battery powered one, but without signal output and warning output. The battery is lithium battery with 3.6V and can last 2-3 years. There is electricity capacity display in LCD right side, which can remind customer to change battery in time.

Part Six: Size and weight

Overall size & weight

1. Bottom in, top out type

A. Reference for size, weight & loss of pressure Basic type

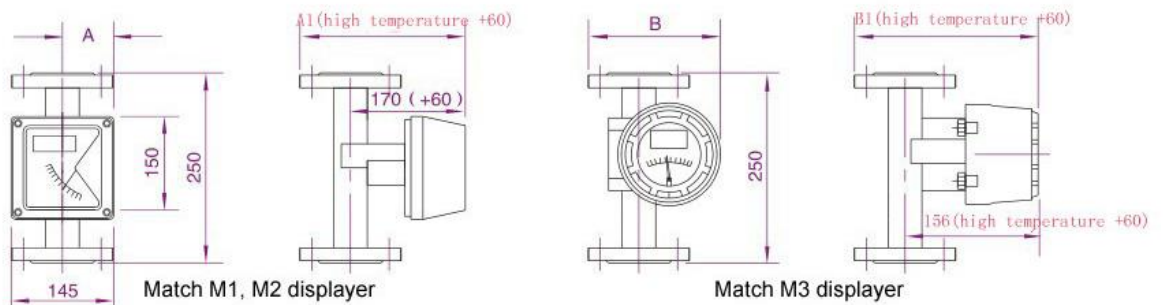

Specification	A	A1	B	B1	G	∠P
DN15	75	220	240	205	3.8	14
DN25	84	230	260	215	5.4	19
DN50	98	260	300	240	8.9	23
DN80	110	270	330	260	14.4	33
DN100	120	280	350	270	15.6	42
DN150	140	320	406	300	33.9	60
DN200	160	350	460	330	48.8	70

B. Reference for overall, size & weight of steam tracing Heat protection jacket type(without steam tracing connection flange)

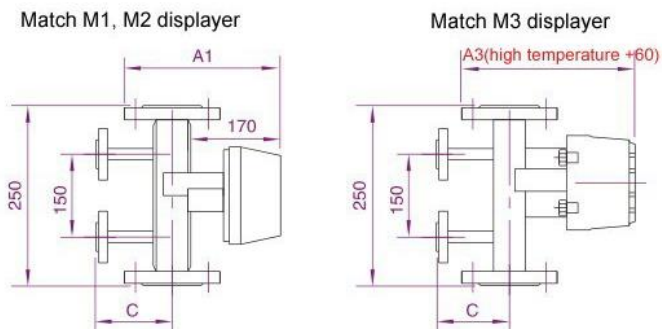

Specification	C	A3	G
DN15	110	135	7
DN25	110	155	11
DN50	120	195	15
DN80	145	225	21
DN100	155	250	22
DN150	190	320	27
DN200	220	380	31

Connection flange of steam tracing DN20 PN1.0

Note: G means reference weight of instrument

C. Reference for overall, size & weight PTFE lining type

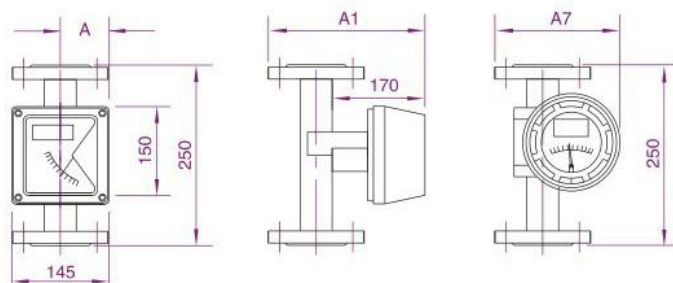

Specification	A1	A7	G
DN15	220	240	7
DN25	230	260	8
DN50	255	300	12
DN80	270	330	17
DN100	280	350	18

D. Reference for overall, size & loss of pressure Sanitary polished tube type

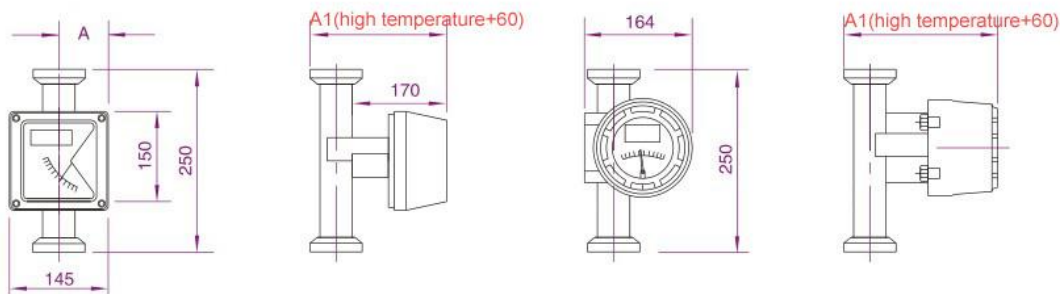

Specification	A	A1	G	ΔP
DN15	75	190	2.5	14
DN25	84	200	3.6	19
DN50	98	216	5.0	23
DN80	110	230	7.6	33
DN100	120	240	8.5	42

Note: G means reference weight(kg), ΔP means loss of pressure(kPa)

A. Bottom in, laterally out from top (Heat protection jacket type without steam tracing connection flange)

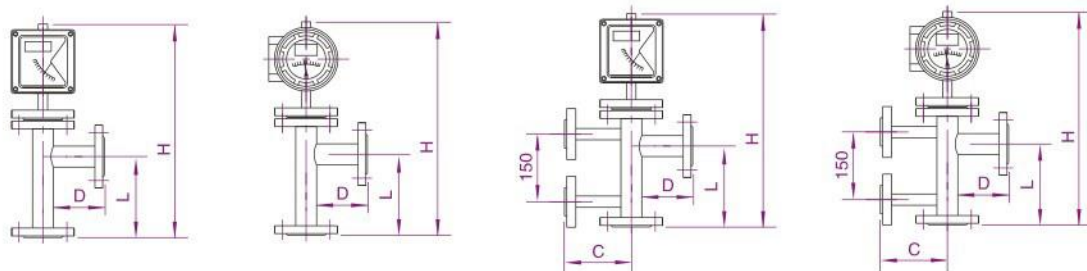

Steam tracing type connection flange DN20 PN1.0

	H1	L	D	C	G	ΔP
DN15	550	250	120	110	8	18
DN25	550	250	120	110	9	22
DN50	560	250	120	120	16	28
DN80	570	250	150	140	25	35
DN100	570	250	150	150	30	45
DN150	570	300	180	190	53	58
DN200	620	350	200	200	60	70

Note: G means reference weight(kg), ΔP means loss of pressure(kPa)

B. Lateral bottom in and top laterally out type (Heat protection jacket type without steam tracing connection flange)

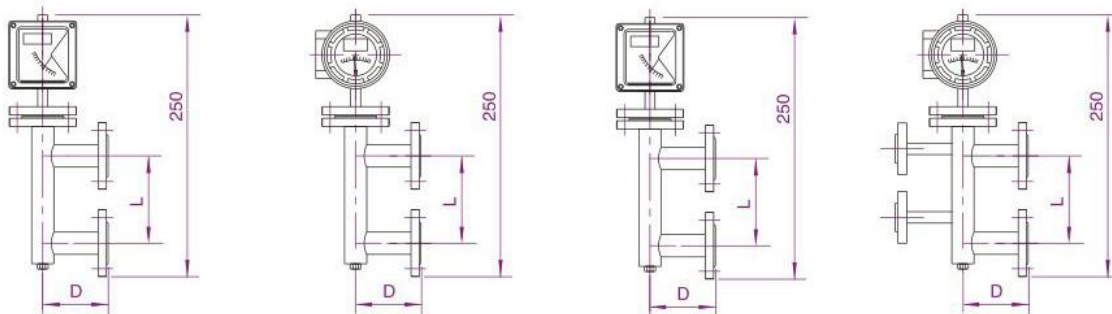

Steam tracing type connection flange DN20 PN1.0

Specification	H1	L	C	D	G	ΔP
DN15	550	250	100	120	7	20
DN25	550	250	110	120	11	28
DN50	560	250	120	120	22	36
DN80	570	300	140	150	32	45
DN100	570	300	150	150	49	58
DN150	570	350	190	180	59	63
DN200	620	400	210	200	70	70

Note: G means reference weight(kg), ΔP means loss of pressure(kPa)

C. Left inflow & right outflow, right inflow & left outflow type (Heat protection jacket type without steam tracing connection fl

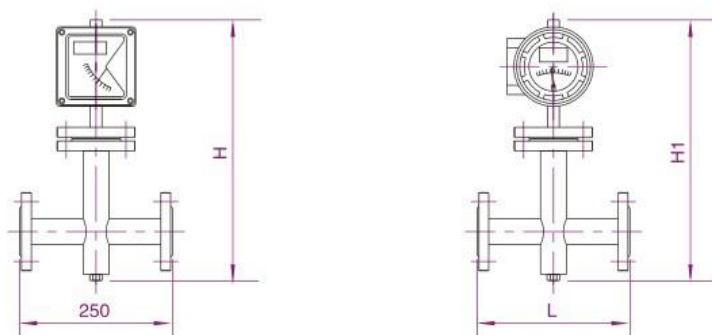

	H1	L	C	G	ΔP
DN15	520	250	145	9	20
DN25	530	250	150	10	28
DN50	560	250	170	17	36
DN80	580	400	150	32	45
DN100	620	400	150	50	58
DN150	640	400	180	68	63
DN200	660	400	200	60	70

Overall size of magnetic filter & straight pipe

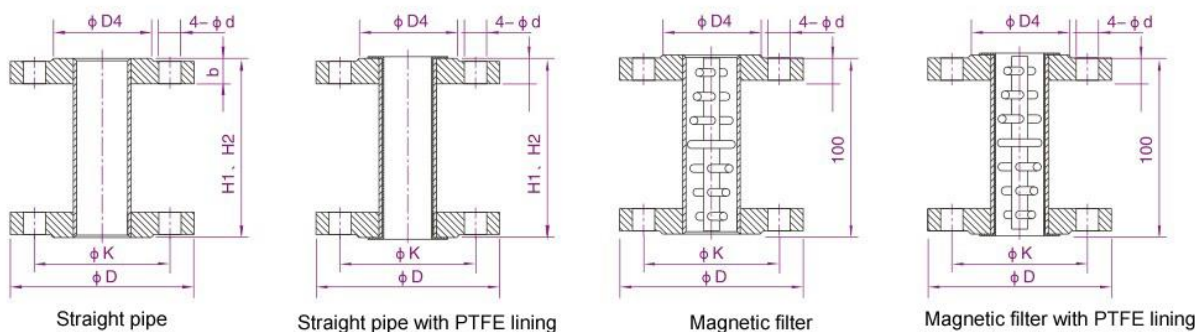

Note: When DN>100, the height of magnetic filter is 150mm.

DN	PN	D	K	D4	n × ϕd	b	H1 (入口)	H1 (入口)
15	4.0	95	65	45	4 × 14	14	75	250
25	4.0	115	85	68	4 × 14	16	125	250
50	4.0	165	125	102	4 × 18	20	250	250
80	1.6	200	160	138	8 × 18	20	400	250
100	1.6	220	180	162	8 × 18	22	500	250
150	1.6	285	240	212	8 × 22	24	750	250
200	1.6	340	295	266	12 × 22	24	1000	250

Part Seven: Wiring Diagram

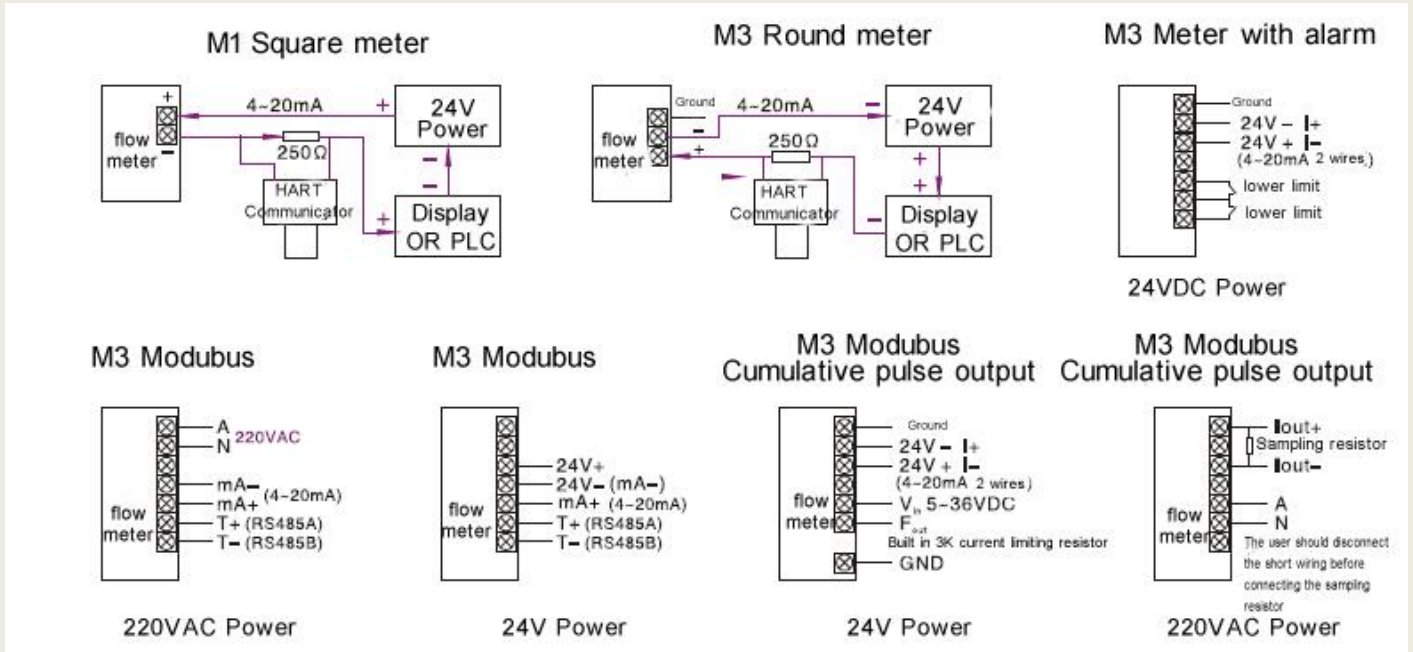

Note:

1. When it is used under requirements of explosion-proof environment, products choose and cable connection should obey the rules of P.R.C. regarding to hazardous locations.
2. Products wiring regards to marks inside products.

Part Eight: Ordering number

LZ-	1	2	3	4	5	6	7	8	9	10	11	12	13	14
-----	---	---	---	---	---	---	---	---	---	----	----	----	----	----

1	Indicator type							
	Z: local type				D: remote type			
2	Nominal diameter and Sealing surface							
	15	25	40	50	80	100	150	200
	DN15	DN25	DN40	DN50	DN80	DN100	DN150	DN200

3	Structure type					
	A	B	C	DR	DL	
	Bottom in& Top out type	Bottom in&Right out type	Right in& Right out type	Right in & Left out type	Left in & Right out type	
4	Material of Measuring tube					
	R0	R1	R4	RL		
	0Cr18Ni12Mo2Ti(316)	1Cr18Ni9Ti(321)	0Cr18Ni9(304)	00Cr17Ni14Mo2(316L)		
	RP	RW	HC	Ti		
	304+PTFE	Polished pipe(304)	Hastelloy C	Titanium		
5	Additional structure					
	0	B	T	G	Y	Z
	Standard	Heat insulation	Steam-heating	High temperature	High pressure	Damping
6	Fixed Pressure(Unit: MPa)					
	1.6	4.0	16	25		
	DN80~DN200	DN15~DN50	DN80~DN200	DN15~DN50		
7	Working temperature					
	E: Standard -70~+180℃	J: Anti-corrosion -40~+150℃	H: High Temperature -70~+350℃	T: customize		
8	Indicator type					
	M1	M3A	M2	M3		
	Square local indicator	Round local indicator	Square digital indicator(Exia)	Round digital indicator(Exd)		
9	Power supply type, signal output& transmitting					
	N/A	M1 and M3A local indicator				
	A	85~265VAC				
	B	3.6V battery				
	D	24VDC				
10	Output					
	E	T	B	H	M	
	4-20mA DC	Pulse	Upper-lower alarm	HART	Modbus	
11	Enclosure class					
	65: IP65	67: IP67				
12	Counter flange					
	N/A	C: Carbon Steel	B: Stainless Steel			
13	Flange Standard					
	N/A: GB/T 9119-2010	1: ANSI B 16.5	2: Other standard			
14	Additional device					
	Straight pipe	Z0: N/A; Z1: with stainless steel straight pipe; Z2: with PTFE straight pipe				
	Magnetic filter	C0: N/A; C1: with stainless steel filter; C2: with PTFE filter				

Note:

1. Special size ordering needs confirmation with factory first.
2. When no flange standard, refer to GB/T 9119-2010. Otherwise, please point out the flange standard.
3. When difficult in purchasing SS316 material, use SS316L to replace.
4. Other pressure rating available.

Part Nine: Installation diagrams

5×DN—inflow straight pipe that is 5 times of connection size.
 250—outflow straight pipe
 100—the position for installation of the magnetic filters if needed.

Bottom in & top out type

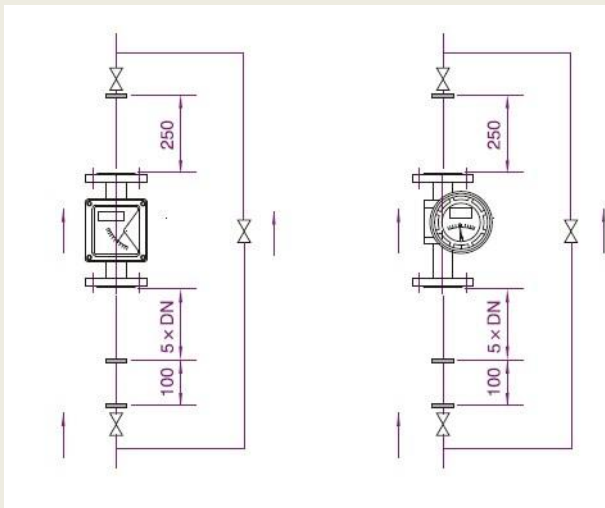

Bottom in & right out type

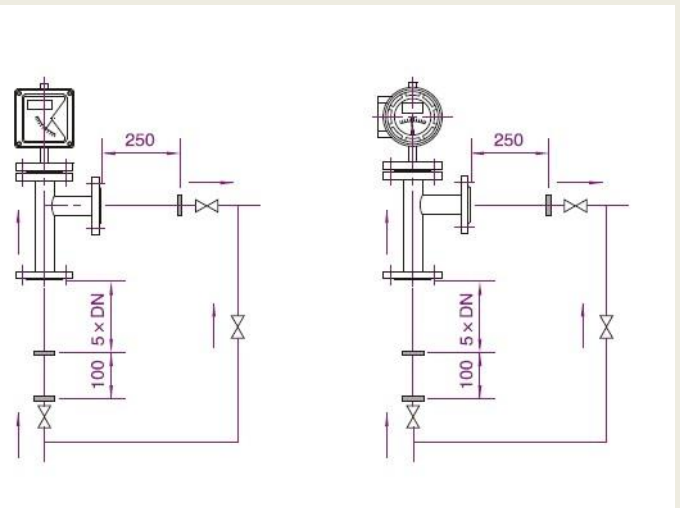

Right in & right out type

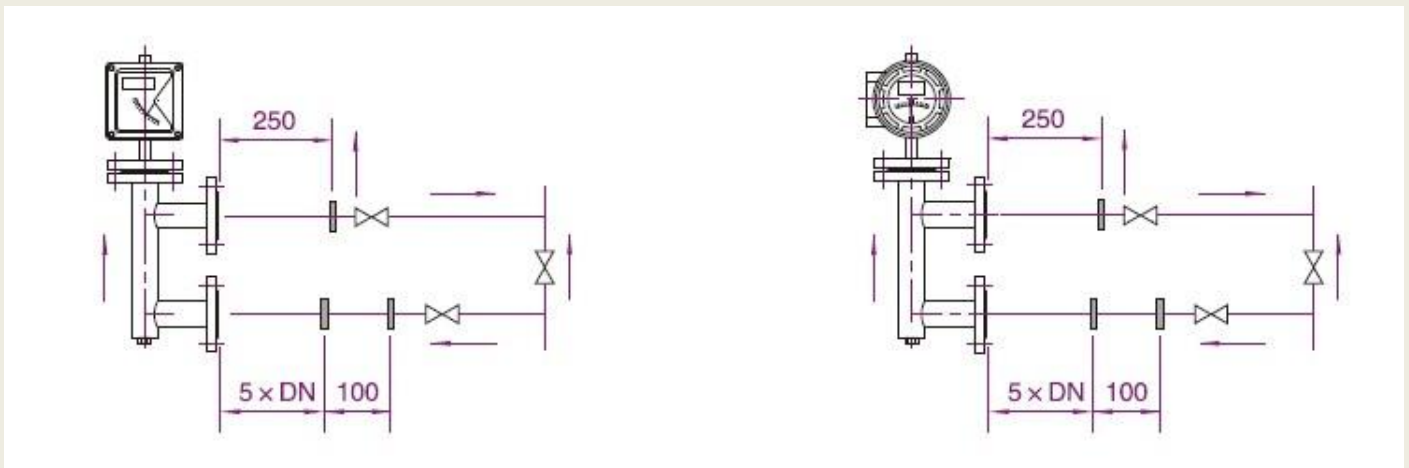

Left in & right out type, right in & left out type

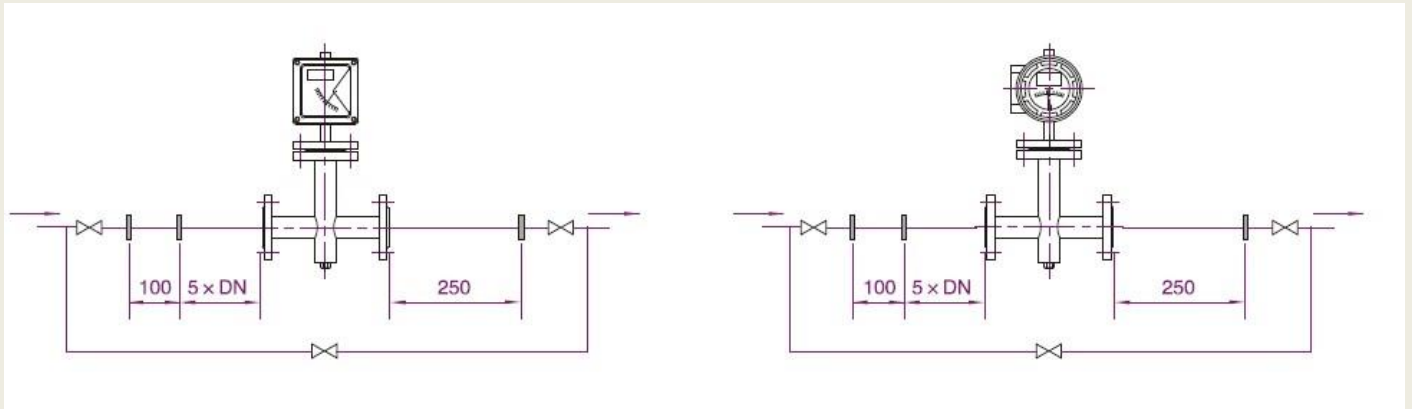

Part Ten: Installation and Maintenance

Installation

1. Instruments are precision measurement devices. Take it carefully and slightly during the transportation and storage.
2. Before installation, make sure the pipe is clear. When solid inside the fluids, install an additional filter to avoid the float blocking. If anything with magnet inside the fluids, a magnetic filter is a must.
3. Before installation, check whether the products is in good condition. Make sure upstream straight is 5DN, and downstream is at least 250mm.
4. Vertical and horizontal mount available. If it is vertical mount, make sure the non-vertical degree is less than 2.5; if horizontal mount, make sure horizontal and vertical degree are both 2.5. No things containing magnet within 100mm.
5. Open the housing, take the needle pointer protector away. Do not make any changes on their location, otherwise the accuracy will be fected. Tare apart the float stop-moving device in the high part of the flow meter, make the float lift from the lower part, check the float and needle pointer performance.
6. Open the housing, connect cable to cable grand. After correct wiring, tighten the nuts.
7. Install on non-vibration tubes vertically or horizontally. Valves are recommended for future maintenance use.
8. When measure gas flow, a control valve should be installed on the outlet.
9. When install instruments with PTFE liner, must be very careful. PTFE is easy to change even in low temperature conditions with the help of pressure. Thus bolts and nuts used in flanges should not be too tight. See table for max torque.
10. Make sure the electric wiring correct before connecting power supply to protect the instruments.

Torque recommended for PTFE liner flow meter

Size(mm)	Max Torque (N.m)	Double Bolts
15	9.10	4 x M12
25	21.9	4 x M12
50	54.3	4 x M16
80	46.1	8 x M16

100	48.8	8 x M16
125	52.7	8 x M18
150	67.4	8 x M20

Operation

1. Liquid measurement: open valves slowly to protect instruments.
2. Gas measurement: a damping and a valve to adjust the flow rate are necessary. Before operating, close the valve on the outlet. After open valves on the inlet, then open the valve on the outlet slowly, control the angle to prevent the float from vibration. To make it work well, the pipe pressure should be at least 5 times of the pressure lose.
3. If it works not well, the reasons to make the needle pointers up and down is below: the input of the flow rate itself, and the mix-up fluids by liquid and gas. To make sure the goods work well, must make sure it is single status fluids.

Maintenance

1. Make sure the relative position of indicator and transmitter to be the same all the time. If it is changed, the accuracy will be affected.
2. During the usage, there will be many magnetic things attached to the float. If it is too much, the float will get stuck or the accuracy will be affected. Thus, to clear the goods after a long time use is a necessary thing, especially the orifice plate part, v-cone and float.
3. Electric units are inside the indicators. Thus, during the process or removing the housing, be sure the housing, bolts & nuts are tight to make the housing fully sealed. Do not let liquid or magnet into the housing. Make the goods on the ground stably.

Part Eleven: Smart indicators setting

(One) Parameters setting and scan

The digital indicators show the instant flow and the total flow. Use the 4 keys on the screen to check the goods parameters, and to reset some of them, which is called the calibration process.

The basic parameters are open to customers. It can be checked and revised using the correct passwords.

1. Meaning of the 4 keys:



SET: Menu to confirm

AT: Left

INC: +1, or to check the next page(Page Down)

DEC: -1, or to check the previous page(Page Up)

2. Basic Setting:

CODE: 000001

(1) Meaning of the setting and explanation

Parameter	Meaning	Range	Explanation
dP1	Setting decimal point	Range ≤ 60 , 3 decimal pointers available; Range ≤ 600 , 2 decimal pointers available; Range ≤ 6000 , 1 decimal pointer available;	No. of decimal points
IEL	Total flow	Automatically record total flow	Read only parameters
dFL	4mA calibration	After entering this, check the current current value with high accuracy ampermeter; enter current value in multimeter.	
dFH	20mA calibration	Same as above	
Cod	Slope modification value	1.0 as default	
SPH	Setting full range		
dLL	Cutting small signal value	Usually setting at 10% of full range	
LPd	Damping value	0-10. Usually 4	
HFP	Final assembly code	No need set HART value when no requirements for HART, output, upper and lower alarm	To set HART value
HFL	Sensor series number	No need set HART value when no requirements for HART, output, upper and lower alarm	To set HART value
HFd	Flow unit	M ³ /h, l/h, Nm ³ /h, NI/h, m ³ /min, l/min, Nm ³ /min, NI/min, kg/h, t/h, kg/min, t/min	0-11
HdL	Installation type	0 for bottom to top direction; 1 for top to bottom direction.	0 as default
HdC	HART communication address	0-15. No need set HART when no requirement	To set HART value
HdP	Device series number	No need set HART when no requirement	
HCH	Manufacturer's parameter		
SoP	Esc		

When converter is upper and lower alarm type, HFP, HFL and HFD have different meaning. See below:

Parameter	Meaning	Range	Explanation
HFP	Upper alarm	0- full range	Can be modified. Work when instant

			flow is higher than the one setted
HFL	Low alarm	0- full range	Can be modified. Work when instant flow is lower than the one setted
HFd	Alarm point hysteresis set	0-255	When no decimal point
		0-25.5	When 1 decimal point
		0-2.55	When 2 decimal points
		0-0.255	When 3 decimal points

Note:

1. When setting alarm point value, upper alarm point value should be higher than lower one;
2. Contact capacity: 24VDC 0.2A, passive switch output
3. Steps to enter the function screen: Press SET key when "CodE" shows, pressure "AT" key to move the arrow, then "INC" or "DEC" to put the according codes. "SET" to confirm.
4. Modification the parameters: users can modify the basic parameters. After entering the code, use "page Up" or "Page Down" to check the relative parameters, "AT" to enter. Use "AT" and "INC" or "DEC" to modify, and then pressure "SET" to confirm.

When in measuring process, for example:

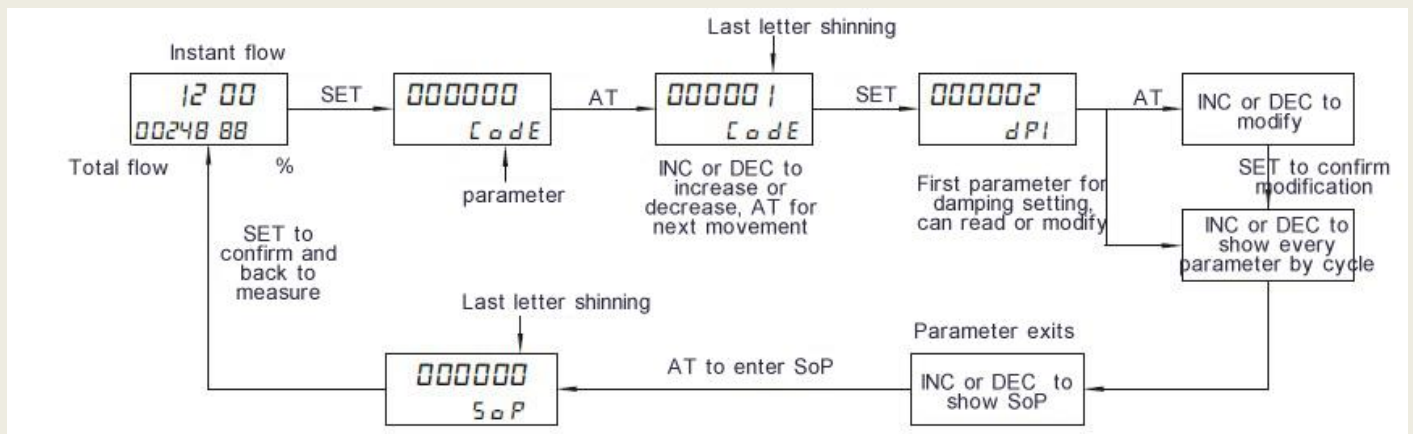

(Two) Codes and functions of digital indicators

1. Basic parameter: Code: 000001. After entering, can check and modify other parameters
2. Manual reset for total flow: Code: 000002. After entering, can make the total flow to be zero, can used to measure and record again
3. Restore factory setting: Code: 000009. After entering, the flow meters setting as it was original.

Appendix (3)

Flow rate form

Diameter	Float model	Water l/h(20°C)		Air m ³ /h(20°C)
		Material: R0,R1,R4,RW,Ti,RL,HC	Material: PTFE lining	Material:R0,R1,R4
DN15	F15.0	1~10		0.03~0.3
	F15.1	1.6~16		0.05~0.5
	F15.2	2.5~25	1.6~16	0.08~0.8
	F15.3	4.0~40	2.5~25	0.1~1.0
	F15.4	6.3~63	4.0~40	0.15~1.5
	F15.5	10~100	6.0~60	0.25~2.5
	F15.6	16~160	10~100	0.40~4.0
	F15.7	25~250	16~160	0.6~6
	F15.8	40~400	25~250	1.0~10
	F15.9	60~630	40~400	2.0~20
	F15.10	100~000		2.8~28
DN25	F25.0	63~630	40~400	1.6~16
	F25.1	100~1000	63~630	2.0~20
	F25.2	160~1600	100~1000	3.6~36
	F25.3	250~2500	200~2000	6.3~63
	F25.4	400~4000	250~2500	10~100
	F25.5	630~6300	400~4000	16~160
DN50	F50.1	630~6300	400~4000	16~160
	F50.2	1000~10000	630~6300	20~200
	F50.3	1600~16000	1000~10000	25~250
	F50.4	2000~20000	1600~16000	40~400
	F50.5	2500~250000	1600~16000	63~630
DN80	F80.0	1600~16000	1000~10000	50~500
	F80.1	2000~20000	1600~16000	63~630
	F80.2	2500~25000	2000~20000	70~700
	F80.3	4000~40000	2500~25000	110~1100
	F80.4	6300~63000	3000~30000	180~1800
DN100	F100.0	4000~40000	2500~25000	120~1200
	F100.1	6300~63000	4000~40000	200~2000
	F100.2	8000~80000		260~2600
	F100.3	10000~100000	6300~63000	300~3000
DN150	F150.0	6300~63000		300~3000
	F150.1	10000~100000	6300~63000	
	F150.2	16000~160000	10000~100000	
DN200	F200.0	16000~160000	10000~100000	
	F200.1	20000~200000	16000~160000	