

Precise

reliability

Machining

CNC vertical turning lathe

Outside diameter	max.	3200 mm
Rotating height	max.	1200 mm
Weight	max.	5 to

CNC boring mill

Length	max.	3000 mm
Width	max.	2000 mm
Height	max.	1400 mm
Weight	max.	5 to

CNC center lathe

Outside diameter	max.	800 mm
Turning length	max.	4000 mm
Weight	max.	4 to

CNC milling machine

Length	max.	1525 mm
Width	max.	760 mm
Height	max.	625 mm
Weight	max.	3 to

Measuring technology at Stooss

Length accuracy

2.8 μ on 450 mm length

Approx. measuring range

2000 x 3000 x 1200 mm

FORGEMASTER
STOOSS
STEEL AT ITS BEST

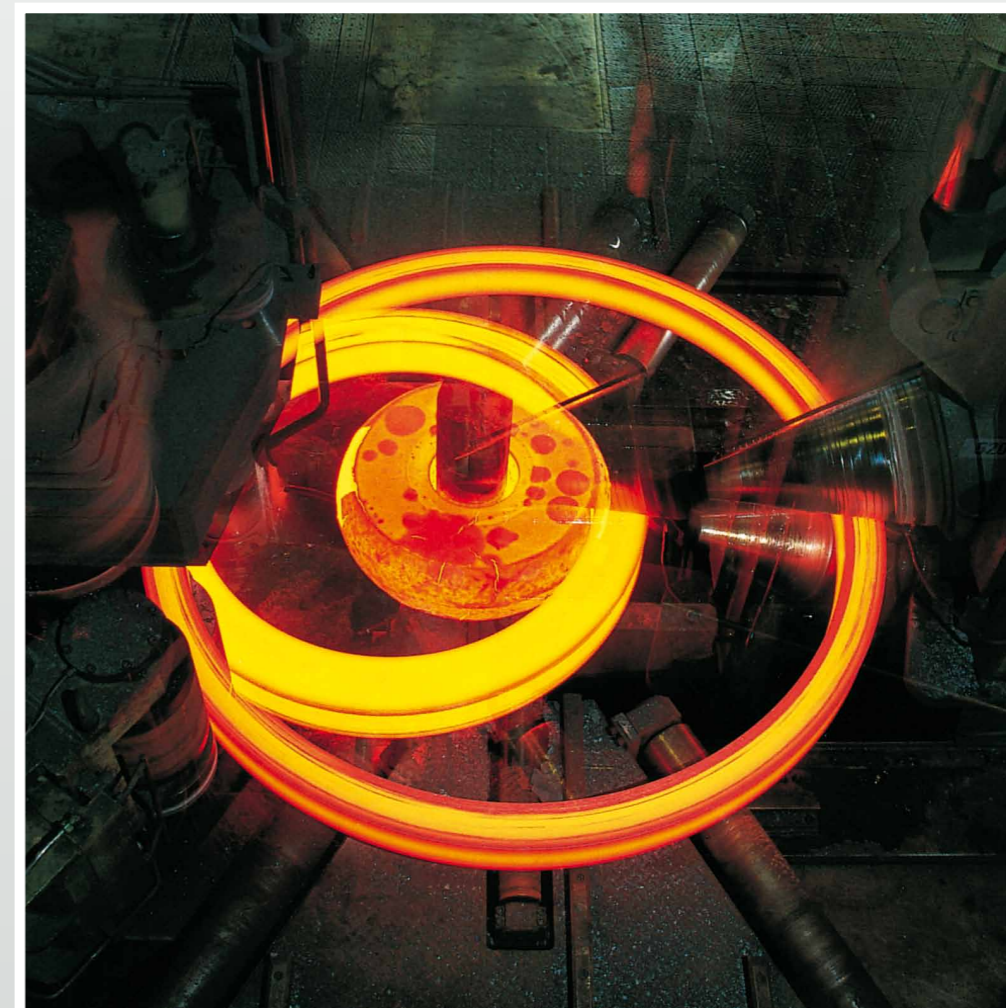

Product Program

FORGEMASTER
STOOSS
STEEL AT ITS BEST



SCHMIEDEWERK STOOSS AG
Maienbrunnenstrasse 8
CH-8908 Hedingen
Telephone +41 43 322 62 00
Fax +41 43 322 62 01
info@stooss.com
www.stooss.com

Stooss forging technology

gives shape to steel...

...and offers its customers exceptional advantages:

Forged parts from Stooss are outstanding because of:

- material selected on the strength of its analysis and degree of purity
- exact shaping
- ideal degree of forming
- optimum grain structure
- minimum allowances
- narrow tolerances

- thermal treatment relevant to the application
- excellent manufacture in terms of surface quality and accuracy of form
- most suitable for processing on CNC machines
- reduction of mechanical processing time thus saving costs
- high degree of security against fatigue cracks



Open-Die Forgings

Rectangular bars and plates

Length	max.	4000 mm
Width	max.	1300 mm
Height	max.	400 mm
Weight	max.	5 to

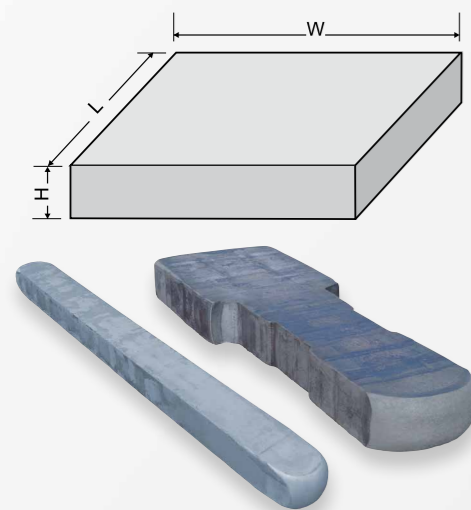

Shafts

Length	max.	4000 mm
Diameter	max.	500 mm
Weight	max.	3 to

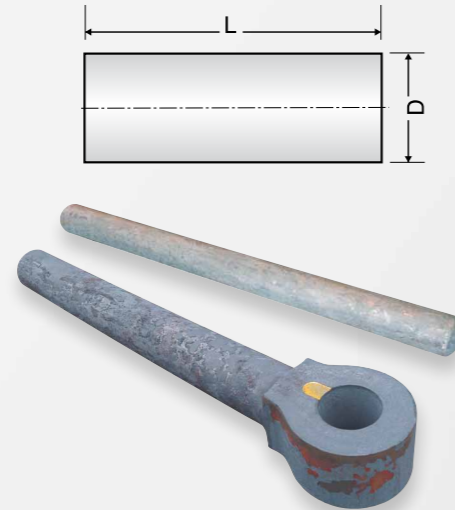

Shafts, flanged shafts, rotors etc.

Length	max.	4000 mm
Diameter	max.	1000 mm
Weight	max.	3 to

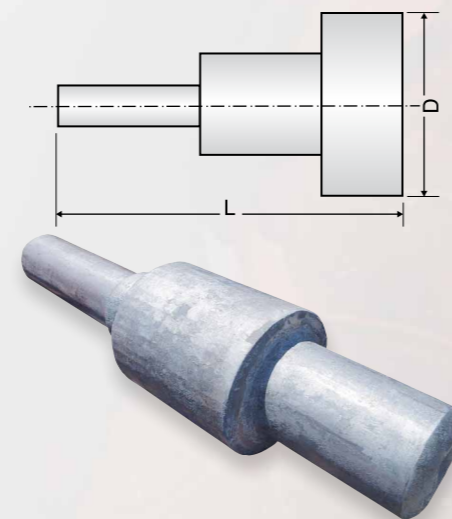

Seamless Hot Rolled Forgings

Rounds blanks, Hubs, solid or punched hole

Height	max.	400 mm
Diameter	max.	1500 mm
Weight	max.	5 to

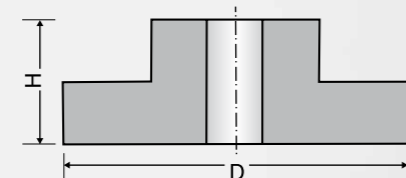

Sleeves

Outside diameter	max.	1300 mm
Inside diameter	min.	200 mm
Height	max.	900 mm
Weight	max.	5 to

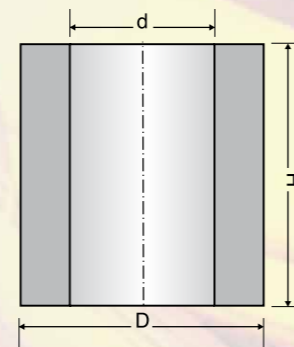

Rings in rectangular shape

Outside diameter	max.	3700 mm
Inside diameter	acc. to request	
Height	max.	700 mm
Weight	max.	5 to

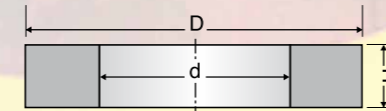

Profiled rings

Outside diameter	max.	3000 mm
Inside diameter	acc. to request	
Height	max.	600 mm
Weight	max.	5 to

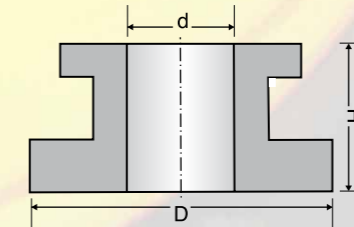

Balls

Outside diameter	max.	920 mm
Inside diameter	acc. to request	
Height	max.	700 mm
Weight	max.	1.7 to

