



MUNSCH

PLASTIC PUMPS FOR AGGRESSIVE MEDIA



Chemical pumps with magnetic drive

MUNSCH STANDARDIZED PUMP CM
MUNSCH CLOSE-COUPLED PUMP CM-B
IN PP/PVDF/PFA



MUNSCH is a highly specialised manufacturer of non-metallic pumps. Fast and reliable solutions – planned through to the minute detail – make us a much sought-after partner to the chemical and process industries worldwide.

Design

Our engineers develop and optimize pumps for your specific needs. Chief among our objectives is to develop high-efficiency pumps providing maximum operating reliability. With their numerically optimized hydraulic design, MUNSCH pumps make a contribution to energy efficiency and plant productivity.

NON-METALLIC PUMPS FOR THE CHEMICAL AND PROCESS INDUSTRIES – FROM THE SPECIALIST

Manufacture

We manufacture all plastic components in-house. Bought-in cast iron and ceramic components are standardized and inventoried in large volumes. Thanks to our high level of vertical integration we are independent of external manufacture and can respond fast and flexibly to customer needs.

Assembly

Our quality testing and documentation procedures ensure product traceability through all stages of production. Our assembly team assembles the pumps using the latest methods and performs the tests/quality inspections at defined hold points on the basis of a rigorous test/inspection schedule.

Testing

No pump leaves our production plant without having undergone a thorough test on our test bench.



MUNSCH STANDARDIZED PUMP CM

MUNSCH CLOSE-COUPLED PUMP CM-B

Magnetically-coupled pumps are the solution of choice whenever there is a need for a hermetically tight pumping environment.

The CM mag drive series is a perfect fit for the safe transfer of fluids posing a health or environmental hazard such as acids, alkalis, solvents or chemically contaminated liquids. An innovative state-of-the-art design ensures their reliable function even if fluids are contaminated with solids.



Applications

Chemical industries, with their variety of demanding processes, often require pumps with increased safety, reliability and flexibility. CM mag drive pumps have been developed putting these topics first. Today MUNSCH mag drive pumps are also being found in many industrial applications like environmental industries, chlorine production as well as electrolysis and electro plating plants where operators have a major focus on reliability and safety.



Use in explosion hazard areas

The CM and CM-B series pumps meet the requirements of EU-Directive 2014/34/EU for use in explosion hazard areas.

WHENEVER SAFETY HAS TOP PRIORITY

Types of construction

CM Series standardized pump with dimensions to EN 22858/ISO 2858/ISO 5199 or CM-B close-coupled pump with casing dimensions to EN 22858/ISO 2858; complemented by size 40-25-125 and 40-25-160 pumps.

Materials

Pump:

The magnetically coupled pumps are available in PP, PVDF as well as in PFA for universal fluid compatibility.

Spacer can:

The spacer can is designed as a metal-free double-wall unit consisting of a shell and a separate can liner. Essentially, this offers the following advantages:

- no eddy currents and hence no heat transfer to the fluid pumped
- no energy losses

The inner spacer can liner is manufactured from pure PFA, the outer pressure-tight can shell is made of high temperature plastics. Thanks to its unique construction, the spacer can is extremely rigid and vacuum-tolerant (temperature-dependent).

Plain bearings:

The standard construction material is silicon carbide, known for its unsurpassed corrosion and wear resistance.

Dry run-protected plain bearings are available as an option. An additional surface treatment makes these bearings tolerant to temporary dry running.

Secondary seals:

O-rings are available in FFPM, gaskets in TFM 1600 and PTFE. Special material grades are available on request.

Reduced maintenance costs

Low-cost gaskets instead of costly O-rings

Pump assembly

No adjustment or alignment work needed either for the pump or the plain bearing

Ease of pipe connection

Ample space for nuts; large clearance between discharge flange and plain bearing holder

Flexible

Flushing connections can be retrofitted at any time; pocket holes are already in place.

Superior to PTFE in diffusion tightness

Spacer can liner made of PFA

Impeller types

Closed, semi-open or vortex designs

Protection from bearing loads

No bearing loads acting on spacer can

Temperature sensor

Directly mounted inside the spacer can; option



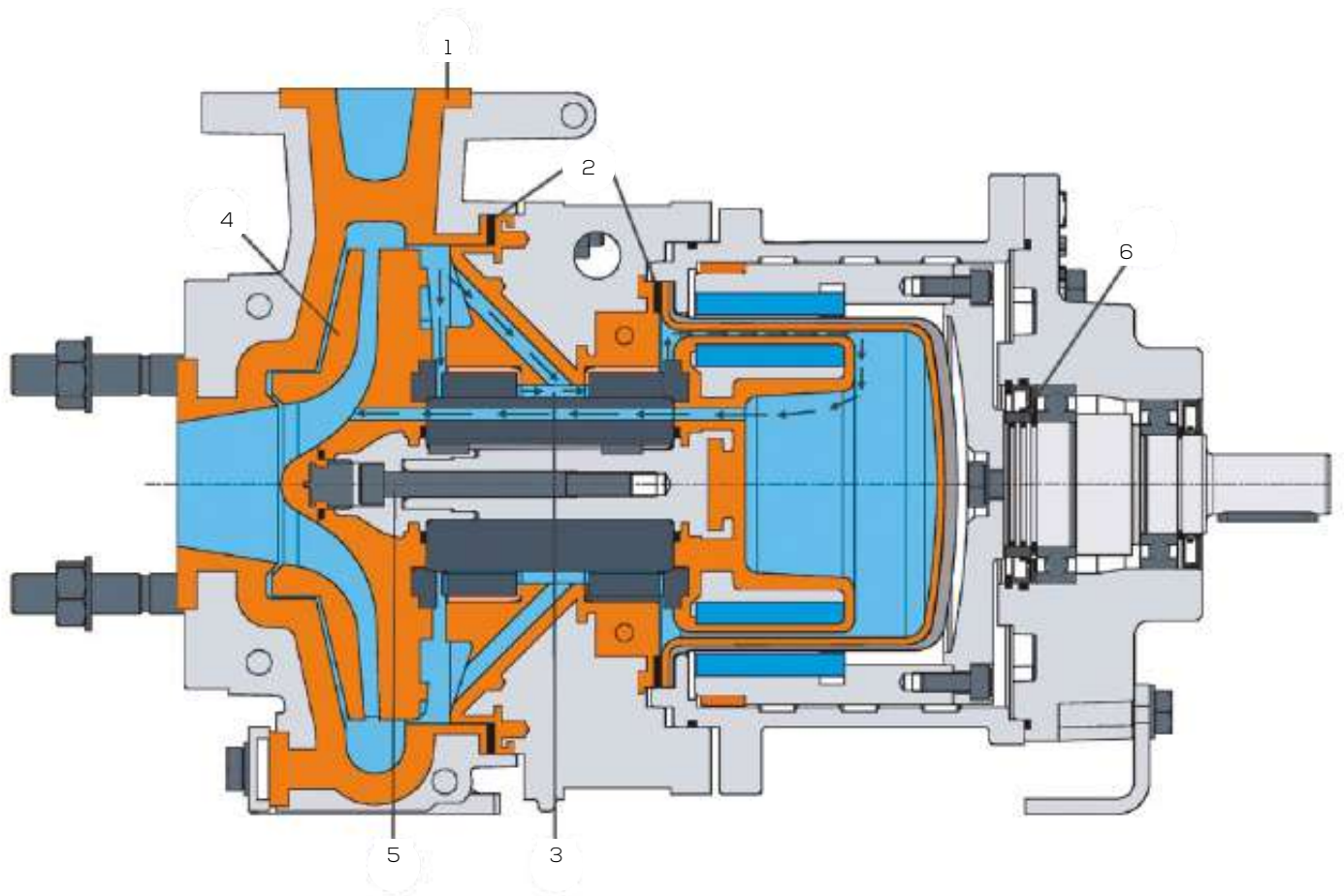

1. Excellent wear allowance

Volute casing with wall thicknesses > 10 mm

2. Casing/spacer can gaskets

Each gasket is separately seated from outside via dedicated cogsets.

3. Lubrication of plain bearings

Fast, continuous forced coolant and lubricant flow

4. Impeller

High efficiencies, low NPSH requirements

5. Impeller mounting

Sense of rotation-independent

6. Secondary seal

Ensures containment of initial leakage; option

Surface coating

The pumps are provided with a high-performance powder coating that withstands even the most arduous operating environments. Paint coatings and special coatings can be provided on request.

Performance data:

Capacity [Q]:	up to 240 m ³ /h
Differential head [H]:	up to 90 m
Service temperature:	up to 190 °C
Solids content:	up to 5 vol. %
Particle size:	up to 5 mm
Discharge nozzle:	from DN 25 to DN 80
Motor rating:	CM: up to 75 kW CM-B/CM-BV: up to 18 kW

✓ For further technical data, see page 18

VOLUTE CASING, SPACER CAN AND PLAIN BEARING HOLDER

Volute casing

The pump casing is designed as a self-supporting volute casing with a minimum wall thickness of 10 mm throughout. Without welds or leak-prone joints. The thick-walled pastics precludes casing deformation, especially at elevated temperatures or under vacuum conditions.

The volute casing is completely encased with a metal armour (material number EN-JS 1025; formerly GGG-40.3). Suction and discharge flanges reliably accommodate all allowable system pressures and piping loads.

Adjustable centre height

The metal-armoured volute casing is bolted to the base plate with the aid of two rigid stainless steel brackets. The height of the mounting brackets is determined by the standardized centre height (h₁) of the pump. Bores and oblong holes provided in the mounting brackets allow an adjustment to the next larger centre height. No spacers are needed between the pump and the base plate.

Casing drain

Residual liquid collects at the low point of the volute casing from where it can be drained via a casing drain. The pump can be supplied with a drain bore or the bore can be subsequently drilled; a pocket hole is provided.

Spacer can

The spacer can is designed as a metal-free double-wall unit consisting of a shell and separate can liner. Essentially, this offers the following advantages:

- no eddy currents and hence no heat generation in the spacer can
- no energy losses and hence no efficiency losses

Depending on the temperature and vacuum level, the spacer can is extremely rigid, retaining its shape not only during operation, but also during pump shutdown.

Plain bearing holder

The volute casing and the intermediate lantern are each connected to the plain bearing holder via a separate bolted joint. As the bolts or nuts are accessible from outside, the gaskets between the volute casing and the plain bearing holder or spacer can can be inspected at any time and the bolts re-tightened, if required.

The plain bearing holder is fitted with two pocket holes with G 1/2" threads. One bore is designed for the installation of a temperature sensor to provide direct temperature monitoring of the spacer can. Via the second bore, the plain bearing can be cooled and lubricated with a product-compatible fluid.



Chemical pump with magnetic drive, CM



Threaded connections for temperature monitoring in the spacer can and/or for plain bearing lubrication via an external source.



The gasket of the volute casing is seated via the bolted joint of the plain bearing holder and the volute casing.



The gasket of the spacer can is seated via the bolted joint of the intermediate lantern and the volute casing.



The centre height can be adapted with the aid of the stainless steel brackets.



 **MUNSCHE**

Visualised pressure distribution in the impeller and the volute casing

Energy-saving and low-wear design

Impellers with high efficiencies and low NPSH requirements help save energy and minimise pump wear, even in challenging service environments.



THE IMPELLER – OPTIMIZED FOR YOUR PUMPING NEEDS

Numerically optimized hydraulics

The fluid dynamics of MUNSCH pumps are calculated, visualized and optimized using the latest numerical techniques (Computational Fluid Dynamics). The result is a hydraulic design with a virtually ideal flow profile.

This means:

- higher pump capacity at unchanged differential head
- reduced energy costs
- improved suction behaviour through low NPSH requirements
- minimized wear in abrasive service conditions
- reduced running noise

Reduced lifecycle cost

The numerically optimized hydraulic design is a key factor in minimizing the lifecycle costs of MUNSCH pumps. Capital and maintenance costs are reduced through the selection of the best suited hydraulic design and optimum motor sizes. Smaller cable cross-sections and lower-rated motor breakers keep down installation costs. The high pump efficiencies directly translate into energy savings.

The pump adapts to the task at hand – impeller designs

MUNSCH has the right impeller design for your specific pumping application. Wear, suction behaviour and efficiency are key factors determining the choice of the impeller. The right combination of impeller (hydraulics), material and shaft seal is all-decisive for a successful pump design and long service lives. MUNSCH pumps are available with closed, semi-open and vortex impellers.

Solids-carrying fluids

A solids deflector in the pump casing redirects solids away from the mechanical seal and back to the flow path of the process fluid.

Impeller and pump shaft – reverse rotation-safe

The impeller is positively locked to the pump shaft for reverse rotation protection (e.g. during the sense of rotation check).

Pump characteristic

MUNSCH chemical pumps feature a steep performance characteristic. This means that the pumps can be adjusted exactly to the operating point.

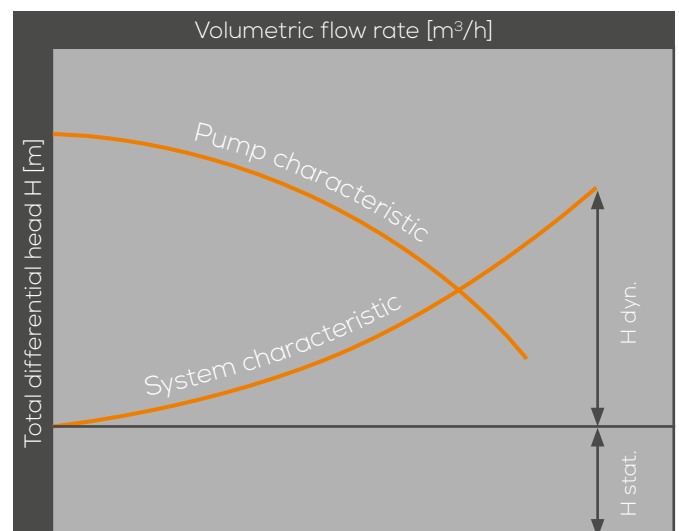

PLAIN BEARING AND INNER MAGNET ASSEMBLY

The silicon carbide with its extreme corrosion and erosion resistance in conjunction with the unique component design make the pump suitable for universal application.

1. Bearing sleeve

The single-piece bearing sleeve is radially secured between the axial bearings of the impeller and inner magnet assembly. A circulation bore provided underneath the running face ensures continuous liquid exchange in the spacer can.

2. Bearing bushing

Two identical bearing bushings are axially and radially secured in the plain bearing holder. The outward pointing faces of the bearing bushings are the contact faces for the axial thrust rings.

3/4. Impeller and inner magnet assembly

The impeller is positively locked to the inner magnet assembly for reverse rotation protection. Torque is transmitted by a polygon. If operating conditions change the impeller can be trimmed or the inner magnet assembly be replaced.

5. Plain bearing sleeve with circulation bore

Compared to conventional non-metallic magnetically coupled pumps, the standardly provided circulation bore drastically expands the application range of the CM / CM-B. The circulation bore ensures both direct venting of the spacer can interior and a fast, continuous forced lubricant flow to the plain bearing.

6. Secondary seals

The Lipseal before the bearings provides secondary containment and protection against uncontrolled leakage. Direct product releases to the atmosphere are ruled out (option).

7. Forced coolant and lubricant flow

A small branch stream of the fluid pumped enters the axial clearance between the plain bearing bushes and flows through the spacer can from where it is returned to the impeller channel via the circulation bore.

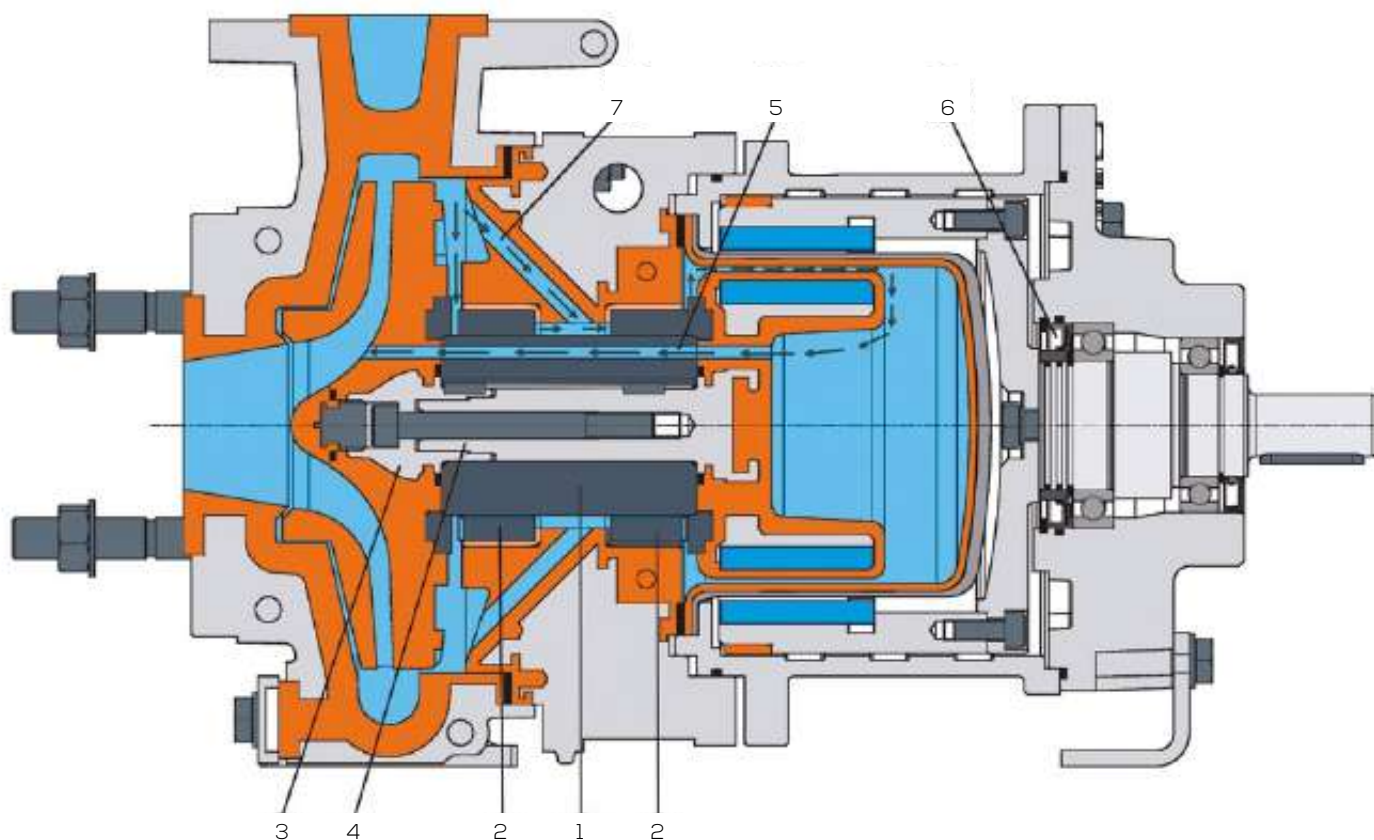



CONTAMINATED FLUIDS, EXTERNAL PLAIN BEARING LUBRICATION

Contaminated fluids

Thanks to the solids deflector and the circulation bore, the standard-design pump can handle temporary or sporadic loads of non-abrasive solids. The solids deflector causes the greater part of the solids to be deflected and directly recirculated to the product stream (see drawing on page 15).

Hence, only a minor fraction of the solids enter the plain bearing area. Of this small fraction, only particles $< 10 \mu\text{m}$ can enter the axial clearance behind the impeller where they are crushed between the bearing sleeve and impeller-side bearing bushing. The crushed particles are carried over with the coolant and lubricant flow to the hydraulic pump section via the circulation bore.

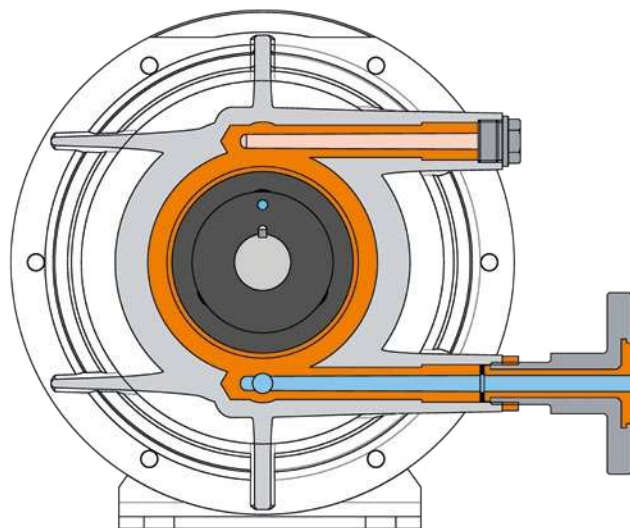

Flushing connection for external plain bearing lubrication

External lubrication system for plain bearing

When permanently pumping solids-carrying fluids, an external lubrication source will be needed for the plain bearing. In such a case, the impeller is not provided with a circulation bore. Instead, a product-compatible flushing medium or liquid lubricant is fed to the spacer can via the G 1/2" flushing connection. The flushing medium/lubricant distributes in the spacer can and enters the fluid pumped via the axial clearance between the plain bearing bushings (see drawing on page 15).

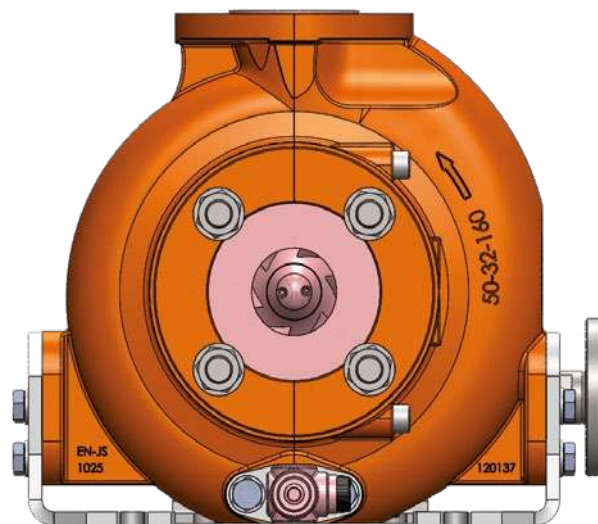

CM with flushing connection and valve for volute casing drainage

Vortex impeller

Pumps with vortex impellers have no blades in the flow path of the volute. The impeller imparts a centrifugal rotating motion to the fluid in the suction nozzle, thereby continuously drawing more fluid into the pump.

As the impeller is located outside the flow path of the fluid being pumped, contact with the process fluid is minimized, allowing clear passage of solids without clogging. Compared to centrifugal pumps with closed or semi-closed impellers, vortex impeller pumps are also better adapted to coping with fluids containing entrained gases. Gas bubbles are captured by the liquid ring and enter the discharge line after only a few impeller rotations.

The CM and CM-B Series pumps are available with a vortex impeller. A spacer ring is installed between the volute casing and the plain bearing holder to recess the impeller into the rear section of the volute. As a result, the "f" dimension increases by 38 mm (see dimensions on page 20).



Pump design with solids barrier, CM-FA

This pump design is suitable for handling fluids with elevated solids loads. An external flushing source is not needed. There is no connection between the spacer can and the pump casing.

CM with vortex impeller and external lubrication system for plain bearing

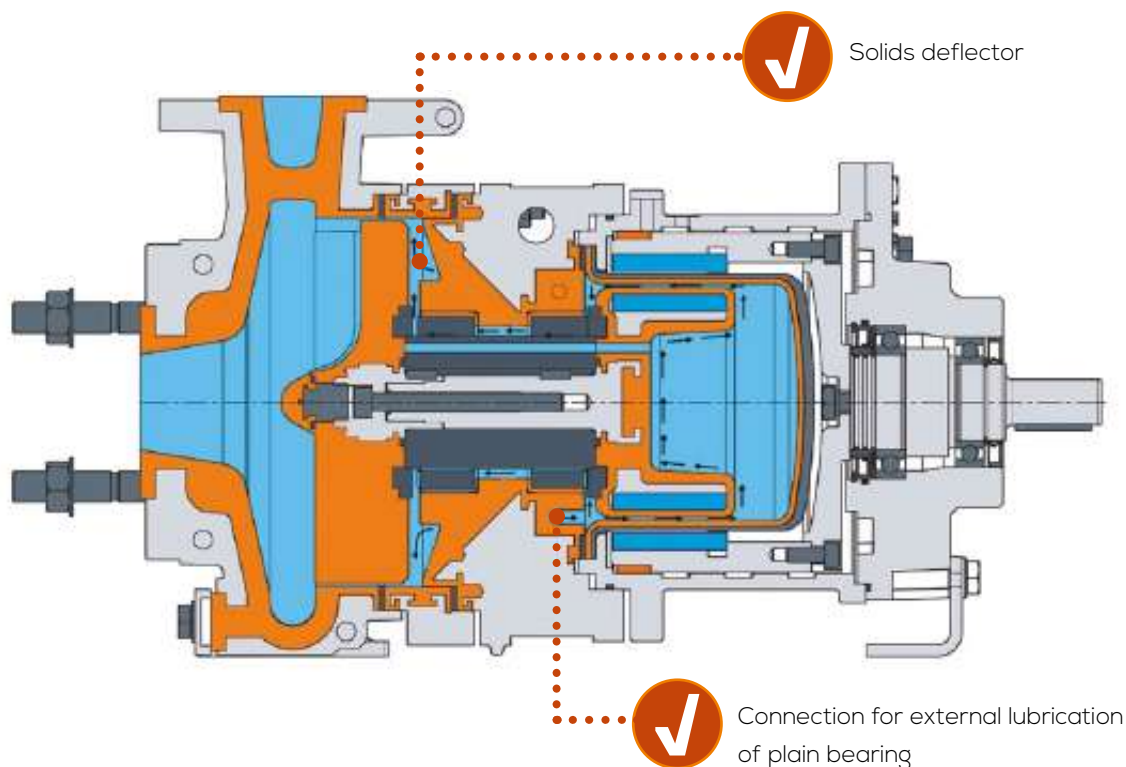

THE MUNSCH SAFETY CONCEPT

Standard CM with the following options

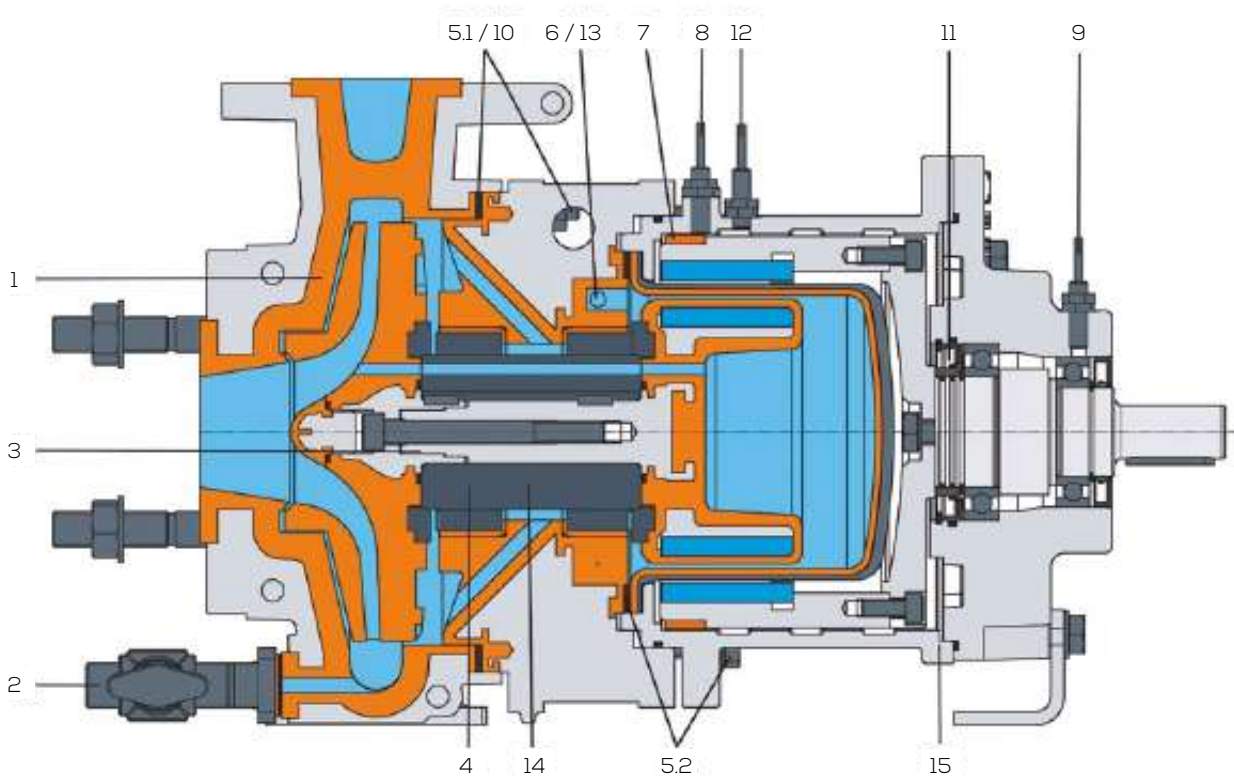

1. Volute casing

The thick-walled volute casing is largely vacuum-resistant and offers maximum protection against high uncontrolled loads of abrasive solids.

2. Casing drain with ball valve

A ball valve allows safe drainage of the volute casing (option).

3. Impeller mounting

The impeller is positively locked to the pump shaft for reverse rotation protection.

4. Plain bearing

No angular bearings; separate axial and radial bearings; hence, no risk of fracture in the case of uneven load distribution.

5.1 Volute casing gaskets

Bolts and nuts are accessible from outside so that the compression of the gaskets can be checked at any time and corrected, if necessary.

5.2 Spacer can gaskets

Bolts and nuts are accessible from outside so that the compression of the gaskets can be checked at any time and corrected, if necessary.

6. Spacer can temperature monitoring

A PT 100 temperature sensor provides direct measurement of the temperature inside the spacer can near the axial bearing.

7. Spacer can contact protection – mechanical protection

Worn bearings affect the true running accuracy of the outer magnet assembly. Under these conditions, there is a risk of the spacer can being damaged by the sharp edges of the outer magnets. To eliminate this risk, the clearance between the outer magnet assembly and the intermediate lantern is smaller than that between the magnet and the spacer can. This prevents the magnets from contacting the spacer can in the case of bearing failure.

8. Spacer can contact protection – electronic monitoring

Inductive proximity switches monitor concentricity run of the outer magnet assembly. In the case of excessive bearing play of the bearings, the proximity switch triggers a signal (option).

9. Temperature monitoring of bearings

The pumps can be supplied with instrument taps for the installation of temperature sensors (PT 100) (option).

10. Disassembly

The volute casing can be removed from the plain bearing holder with the spacer can remaining in place on the plain bearing holder; see bolted connections 5 and 6.

11. Secondary seals

The Upséal arrangement before the bearings provide secondary containment and protection against uncontrolled fluid leakage. Direct fluid leakage to the atmosphere is ruled out (option).

12. Secondary seals – pressure-monitored

In conjunction with the secondary seals, the leak-tightness of the intermediate lantern can be monitored by a pressure sensor or pressure gauge (option).

13. External lubrication system for plain bearing

Plain bearings with external lubrication use an external lubrication source for forced lubricant supply. The external lubrication system for plain bearings (option) is employed

- when there is a risk of sporadic dry running ,
- when the fluid pumped has poor lubricating characteristics ,
- when the fluid pumped contains undissolved gases or is pumped near its boiling point,
- when ingress of solids into the plain bearing clearance must be ruled out.

14. Dry run-proof plain bearings

The CM/CM-B Series pumps can be equipped with dry run-proof plain bearings. This will, however, not be sufficient to provide durable protection against dry running. Effective dry run protection can only be ensured by monitoring the suction head and flow rate.

15. Assembly

Gap dimensions need not be bothered with in pump assembly. No precision measuring tools are needed for adjustment and alignment work. All that is needed for proper pump assembly are commercially available tools.

CM with the following options:

- **Temperature monitoring in spacer can (6)**
- **External lubrication of the plain bearing (13)**



TECHNICAL DATA

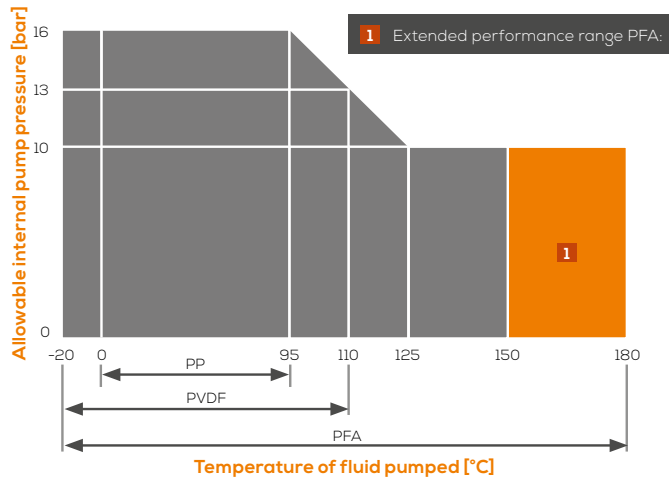

Maximum allowable service pressures and temperatures

Characteristic 50 Hz, 1450 1/min

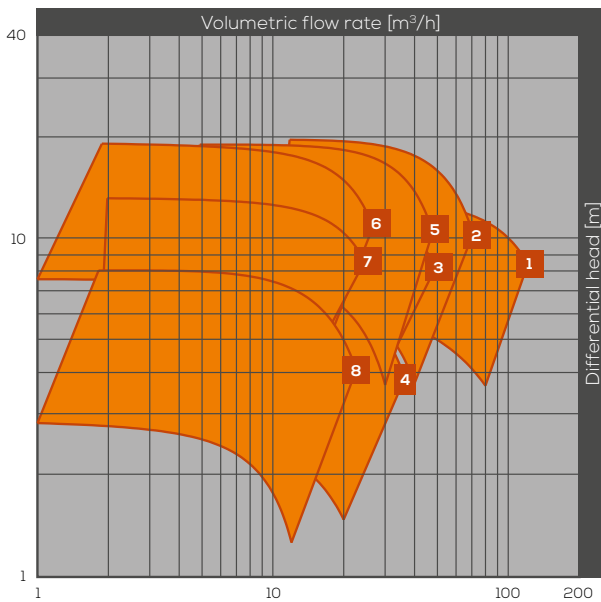

Characteristic 60 Hz, 1750 1/min

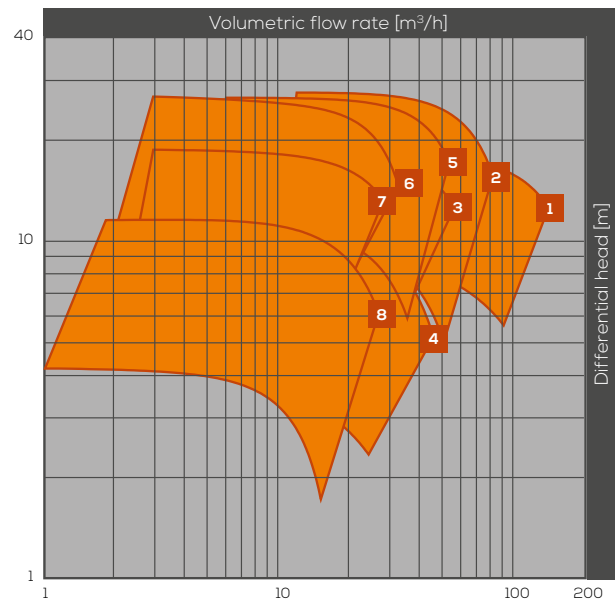

Characteristic 50 Hz, 2950 1/min

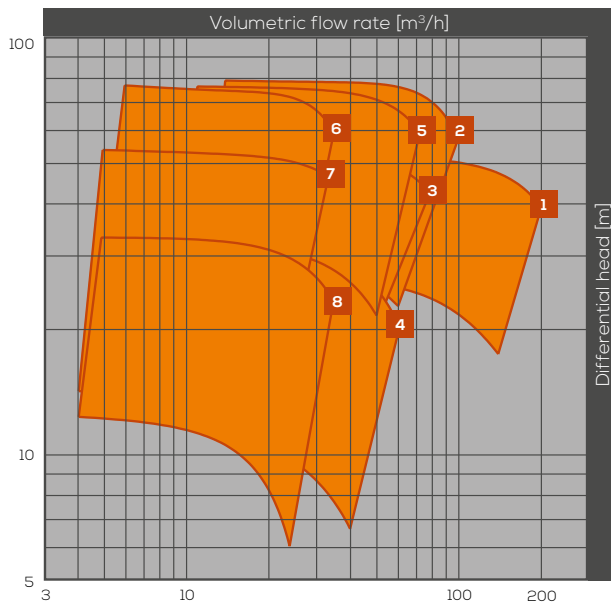

Characteristic 60 Hz, 3550 1/min

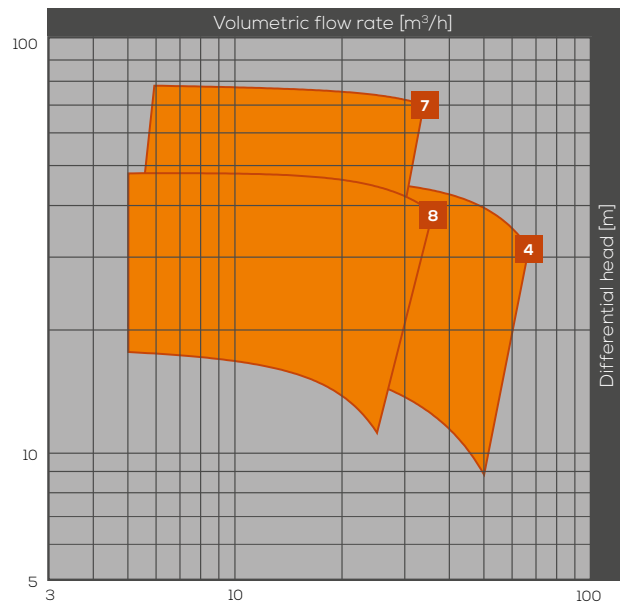

- 1** 80-65 160-A
- 2** 80-50-200-A
- 3** 65-50-160-A
- 4** 65-50-125-A
- 5** 65-40-200-A
- 6** 50-32-200-A
- 7** 50-32-160-A
- 8** 50-32-125-A



Vacuum capability

Depending on the delivery head and temperature, the pump is vacuum-resistant during operation. During shut-down, the spacer can liner limits the allowable negative pressure as a function of the temperature.

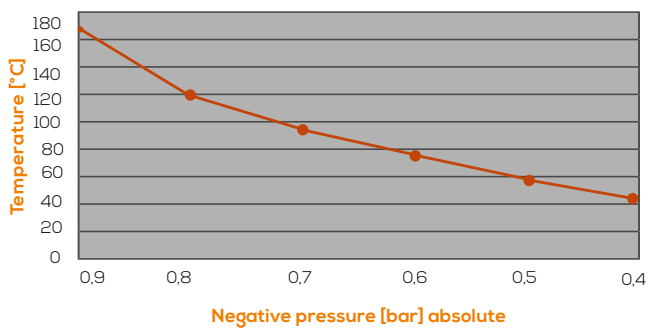

External plain bearing lubrication

The flow rate and pressure of the external lubricant are a function of the internal pump pressure. As the delivery rate increases, the differential head decreases and thus the internal pressure in the spacer can. At the operating point, a lubricant rate of 100 bis 130 l/h is required. The pressure of the external lubricating fluid should be roughly equal to the pressure at the pump discharge nozzle.

Coating system

- Base coat: epoxy resin, film thickness 60-80 µm
- Top coat: polyurethane, film thickness 60-80 µm
- Total film thickness: 130-150 µm
- Paint coating and special coatings available on request

Construction materials

Part designation	Part No.	Standard material range		
		PP	PVDF	Part No.
Volute casing				

1) 314, 380, 5291, 545

Interchangeable parts

A large number of parts are interchangeable within the individual pump sizes, except for the volute casing, casing armour and impeller.

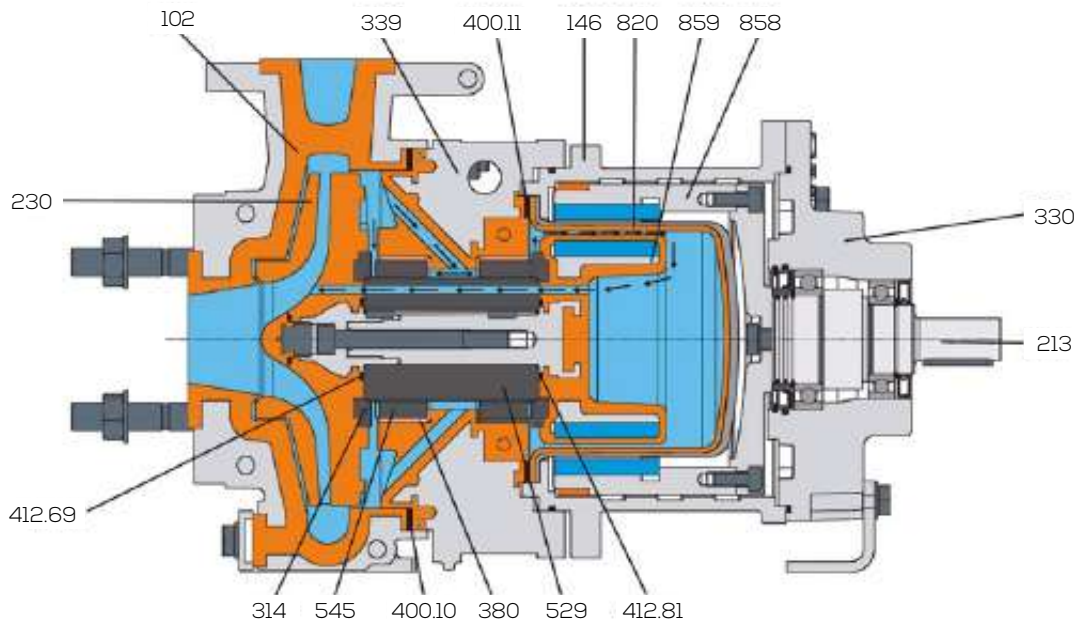

Pump size	CM	40-25-125	50-32-125	65-50-125	40-25-160	50-32-160	65-50-160	50-32-200	65-40-200	80-50-200	80-65-160
Bearing bracket											
		x	x	x	x	x	x	x	x	x	x
146			x			x			x		x
213							x				
230		x	x	x	x	x	x	x	x	x	x
330							x				
339			x			x			x		x
400.10			x			x			x		x
400.11							x				
412.69							x				
412.81							x				
820							x				
858							x				
	1	Outer magnet assembly Size 4 (65 Nm)					x				
	1	Outer magnet assembly Size 5 (100 Nm)		-				x			
859							x				
	1	Inner magnet assembly with featherkey Size 4 (65 Nm)					x				
	1	Inner magnet assembly with featherkey Size 6 (100 Nm)					x				
	1	Plain bearing assembly (314, 38, 529, 545)					x				

MUNSCH PRODUCT RANGE



NPC Mammut beyond-standard chemical pump
with casing armour



NP standardized chemical pump
with solid plastic casing



NP-B close-coupled chemical pump
with solid plastic casing



NPC standardized chemical pump
with casing armour



CM/CM-B standardized chemical pump
with magnetic drive



ECM/ECM-B standardized chemical pump
with magnetic coupling



Priming pot
made of plastics



TNP-KL
vertical chemical pump
with plain bearing



TPC-M
vertical cantilever pump



TNP
vertical chemical pump
with plain bearing



TPC
vertical cantilever pump



MUNSCH *Plastic Welding Technology*

Already heard of it?

Munsch offers you a broad range of hand-held plastic extrusion welders with a full suite of accessories for container engineering, hydraulic engineering and landfill construction applications.

munschwelding.com/en





MUNSCH Chemie Pumpen GmbH

Im Staudchen · D-56235 Ransbach-Baumbach
Postfach 1 42 · D-56221 Ransbach-Baumbach
Germany

Phone: +49 (0) 2623-8 98-90
Telefax: +49 (0) 2623-8 98-95
Internet: www.munsch.de
E-mail: munsch@munsch.de