

hydroo[®]

SDROO SERIES
SX/SN

**Submersible
borehole pump
50Hz**





PRESENTATION

Hydroo Pump Industries SL is an enterprise specialised in the research, development and large-scale production of Stainless Steel centrifugal pumps. We have a vertical integration of the production processes, standing out stamping, welding and motor wiring in 6 value centers and production units. All of them with a high performance management on pump engineering and production quality.

HYDROO has set up a wide range of pumping solutions for many applications as building services, industry, irrigation and industrial process. Customers enjoy of the highest performance in booster sets and pressurization, fire-fighting sets, pumping of underground water, HVAC, drainage and sewage, utilities, desalination and OEM integrations. Versions in 50 Hz and 60 Hz are available, as well as any modification on materials, on request.

Global water challenges require excellence in pumping technologies

and close cooperation between pump designers, manufacturers and pump engineers. In order to better meet the customers' needs and requirements our company is facing an expansion of its operations worldwide, providing timely and effective services in more than 30 countries. With tight relationships in many regions, we're proud to introduce a new regional value center for Europe. We are based near Barcelona at the Girona industrial area. **Hydroo** is a trademark to forge excellent and successful business relationships with our value customers by means of an operative assembling unit and an application engineering unit. **HYDROO** trademark wants to symbolize the firm commitment for a high level service to our value partners.

At Hydroo we bet on a high level service to our value pump partners.

SX, SN

Stainless steel submersible borehole pump

Applications

Water supply
Irrigation
Sprinkling and irrigation

Description

Vertical multistage pump with water-filled or oil-filled NEMA standard submersible motors for 4"-6"-8" deep wells. Built-in non-return valve included. Most parts made of stamped and welded AISI304 Stainless Steel.

Performance range

Capacity: Q up to 260 m³/h

Head: H up to 381 m

Temperature: T up to 25 °C

Speed: n 2900 rpm or 3500 rpm

Power: P up to 110 kW

Standard material

Impeller, diffuser and shaft made in AISI304 SS. Also available, upon request, plastic made inner parts with floating impellers.

Pumps in 3"-4" with composite floating impellers available.



Performance scope

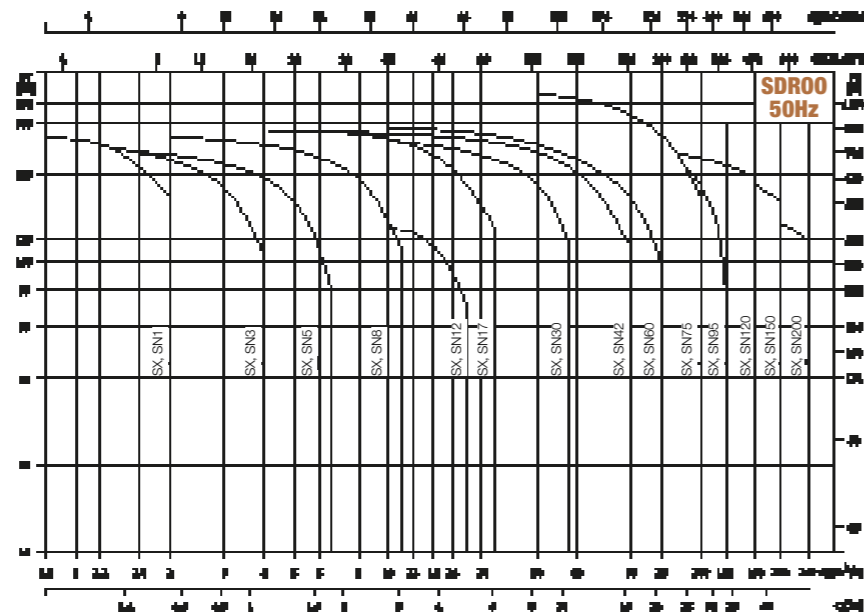

Typical applications

- Circulation or boosting for clean water, demineralized water.
- Water supply, irrigating system.
- Lowering ground water level.
- Boosting.
- Other industrial applications.

Operation conditions

- Solid grain-or-fiber-free dilute clean non-corrosive liquids.
- Maximum liquid temperature: 25 °C
- Maximum working pressure: 38 bar
- pH: 6.5~8.5

Curve conditions

- The curve tolerance complies with ISO9906 Annex A.
- All curves are based on the measured values of 50Hz: constant motor speed 2850r/min or 2900r/min.
- All measurements are carried out with gas-free water of temperature 20 °C. The curve is applicable to kinematical viscosity 1mm/s. In case density of the liquid conveyed by the pump is higher than that of water, it is necessary to use corresponding motor of higher output power.
- The thickened curve means the recommended performances scope.
- The performance curve includes loss caused by check valve etc.

Performance curve

- Q/H curve means flow and head under the rated speed.
- Power curve: P2 means input power of each grade, curves are shown for complete (1/1) and for reduced diameter (2/3) impellers.
- Efficiency curve: Eta means the stage efficiency of the pump.

NEMA Motor

- 4" Motor Stainless steel (there is bronze flange or ss flange)
Single phase: 0.37 kW~2.2 kW
Three phase: 0.37 kW~7.5 kW
- 6" Motor Cast iron (Standard), Stainless steel (If required, need to specify) Three phase: 4 kW~37 kW
- 8" Motor Cast iron (Standard), Stainless steel (If required, need to specify) Three phase: 5.5 kW~110 kW

Product range

Description	SX, SN 1	SX, SN 3	SX, SN 5	SX, SN 8	SX, SN 12	SX, SN 17	SX, SN 30
Rate flow [m ³ /h]	1	3	5	8	12	17	30
Rate flow [l/s]	0.28	0.83	1.39	2.22	3.33	4.72	8.33
Flow range [m ³ /h]	0.2~2	0.8~4	1~6.5	2~11	3~18	4~22	5~38
Flow range [l/s]	0.06~0.56	0.22~1.1	0.28~1.8	0.56~3.1	0.83~5	1.11~6.1	1.39~10.6
Max. pressure [bar]	28	25	24	27	16	26	28
Motor power [kW]	0.37~2.2	0.37~3	0.37~4	0.75~7.5	1.5~7.5	0.55~15	1.1~22
Temp. [°C]	45	56	59	60	60	73	74
Pipe screw joint	Rp1¼	Rp1¼	Rp1½	Rp2	Rp2	Rp2½	Rp3

Description	SX, SN 42	SX, SN 60	SX, SN 75	SX, SN 95	SX, SN 120	SX, SN 150	SX, SN 200
Rate flow [m ³ /h]	42	60	75	95	120	150	200
Rate flow [l/s]	11.7	16.7	20.8	26.4	33.3	41.6	55.6
Flow range [m ³ /h]	5~60	10~75	30~100	40~120	60~150	80~180	100~240
Flow range [l/s]	1.39~16.7	2.8~20.8	8.3~27.8	11.1~33.3	16.5~41.6	22.2~50	27.8~66.7
Max. pressure [bar]	28	29	38	34	25	23	16
Motor power [kW]	1.1~37	2.2~37	7.5~75	9.2~75	11~110	9.2~110	30~110
Temp. [°C]	75	79	79	80	77	77	79
Pipe screw joint	Rp3	Rp4	Rp5	Rp5	Rp6	Rp6	Rp6

Definition of model

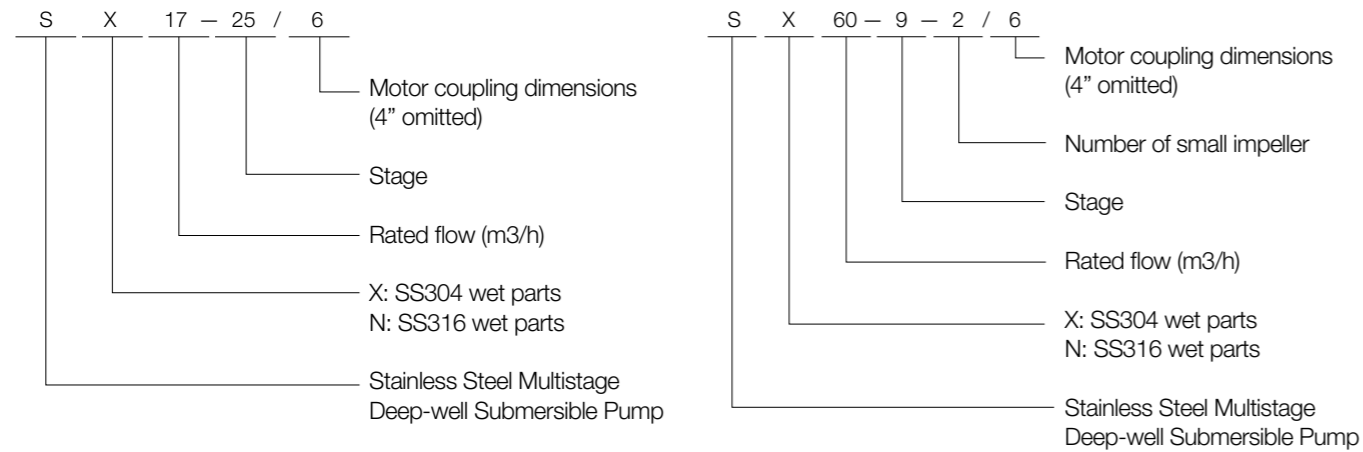

Section drawing

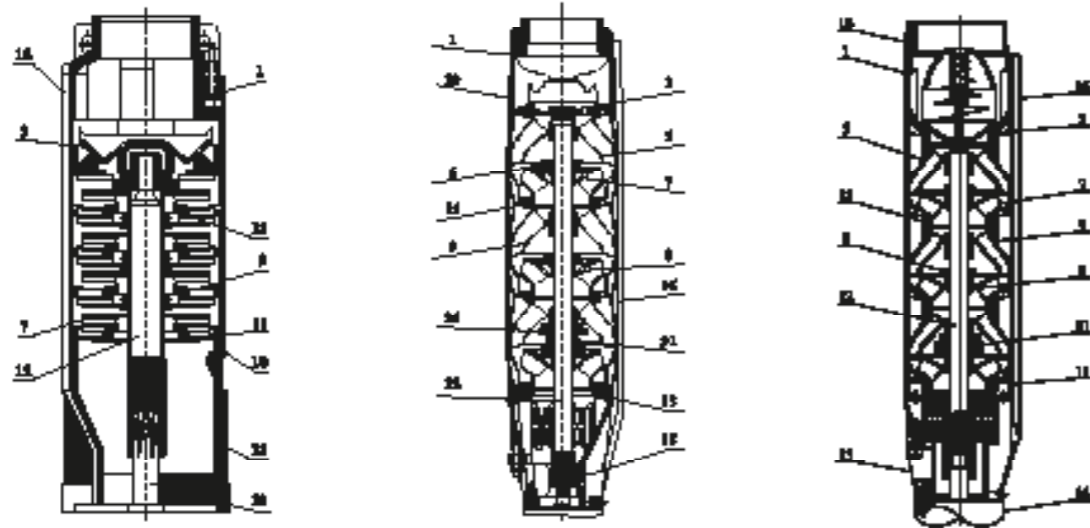

Material

N°	Name	Material	AISI
1	Discharge head	SS304	AISI304
3	Valve cap	SS304	AISI304
5	Discharge diffuser	SS304	AISI304
6	Impeller nut	SS304	AISI304
7	Impeller	SS304	AISI304
8	Impeller cone	SS304	AISI304
9	Diffuser	SS304	AISI304
10	Straps	SS304	AISI304
11	Inducer	SS304	AISI304
12	Pump shaft	SS304/420/431	AISI304/420/431
13	Suction Interconnector	SS304	AISI304
15	Neck ring	SS304	AISI304
16	Cable guard	SS304	AISI304
18	Submersible motor		
21	Inlet spacer	Carbon	
31	Connecting sleeve	SS304	AISI304

SX, SN 1

Performance curve ISO9906 Annex A 2850rpm

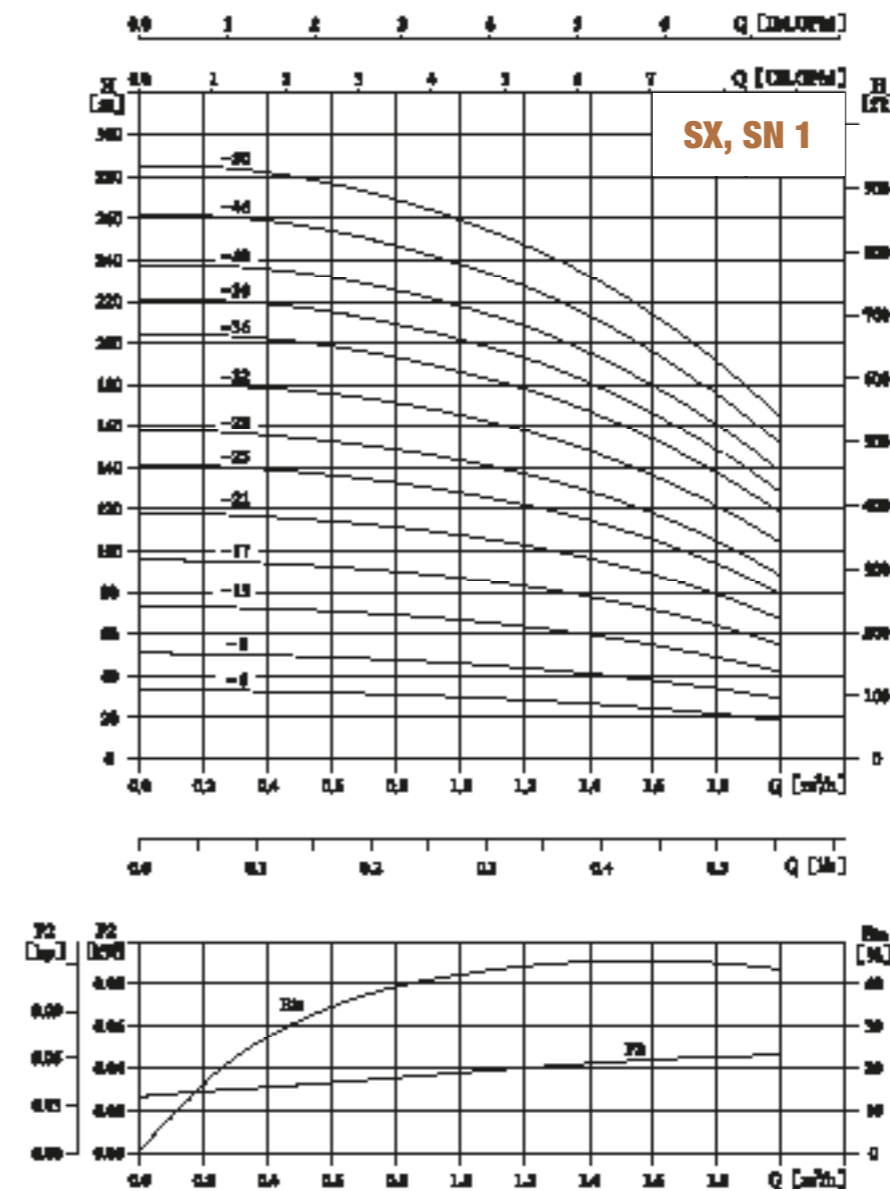

Installation sketch

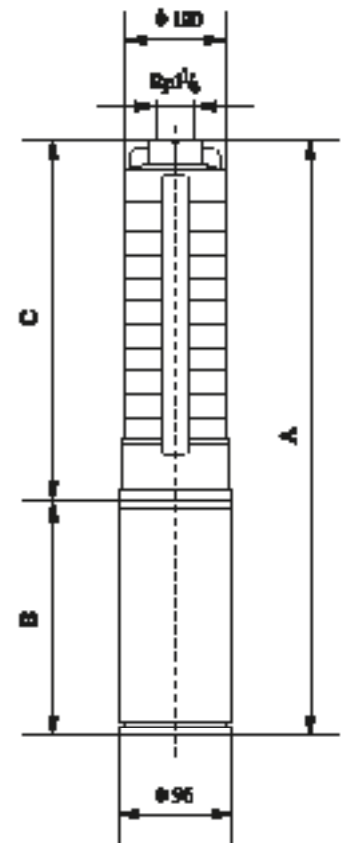

Performance table

Model	Driving motor (kW)		Q (m³/h)	Q (m³/h)															
	(kW)	(hp)		0.2	0.4	0.6	0.8	1.0	1.2	1.4	1.6	1.8	2.0						
SX, SN1-6	0.37	0.5	H (m)	33.5	33	32	31	30	29	27	25	22	19						
SX, SN1-9	0.37	0.5		51	50	49	48	46	44	41	38	34	29						
SX, SN1-13	0.55	0.75		73	72	71	69	67	64	60	55	49	42						
SX, SN1-17	0.75	1		96	95	92	90	87	84	78	71	64	55						
SX, SN1-21	1.1	1.5		119	118	115	112	108	103	97	89	80	69						
SX, SN1-25	1.1	1.5		141	140	137	134	129	123	116	106	95	82						
SX, SN1-28	1.5	2		158	157	153	150	145	138	130	119	107	92						
SX, SN1-32	1.5	2		180	179	175	171	165	158	148	136	122	105						
SX, SN1-36	1.5	2		203	202	197	192	186	178	167	153	137	118						
SX, SN1-39	2.2	3		221	219	214	209	202	193	181	166	149	128						
SX, SN1-42	2.2	3		238	236	230	225	217	208	195	179	160	137						
SX, SN1-46	2.2	3		260	258	252	246	238	227	213	196	176	151						
SX, SN1-50	2.2	3		284	282	276	269	260	248	233	214	192	165						

Size and weight

Model	Size (mm)			Weight (kg)
	A	B	C	
SX, SN1-6	667	370	297	12
SX, SN1-9	730	370	360	13
SX, SN1-13	S24	380	444	15
SX, SN1-17	928	400	528	17
SX, SN1-21	1052	440	612	19
SX, SN1-25	1136	440	696	20
SX, SN1-28	1229	470	759	23
SX, SN1-32	1313	470	843	24
SX, SN1-36	1397	470	927	25
SX, SN1-39	1500	510	990	29
SX, SN1-42	1563	510	1053	30
SX, SN1-46	1647	510	1137	31
SX, SN1-50	1731	510	1221	32

SX, SN 3

Performance curve ISO9906 Annex A 2850rpm

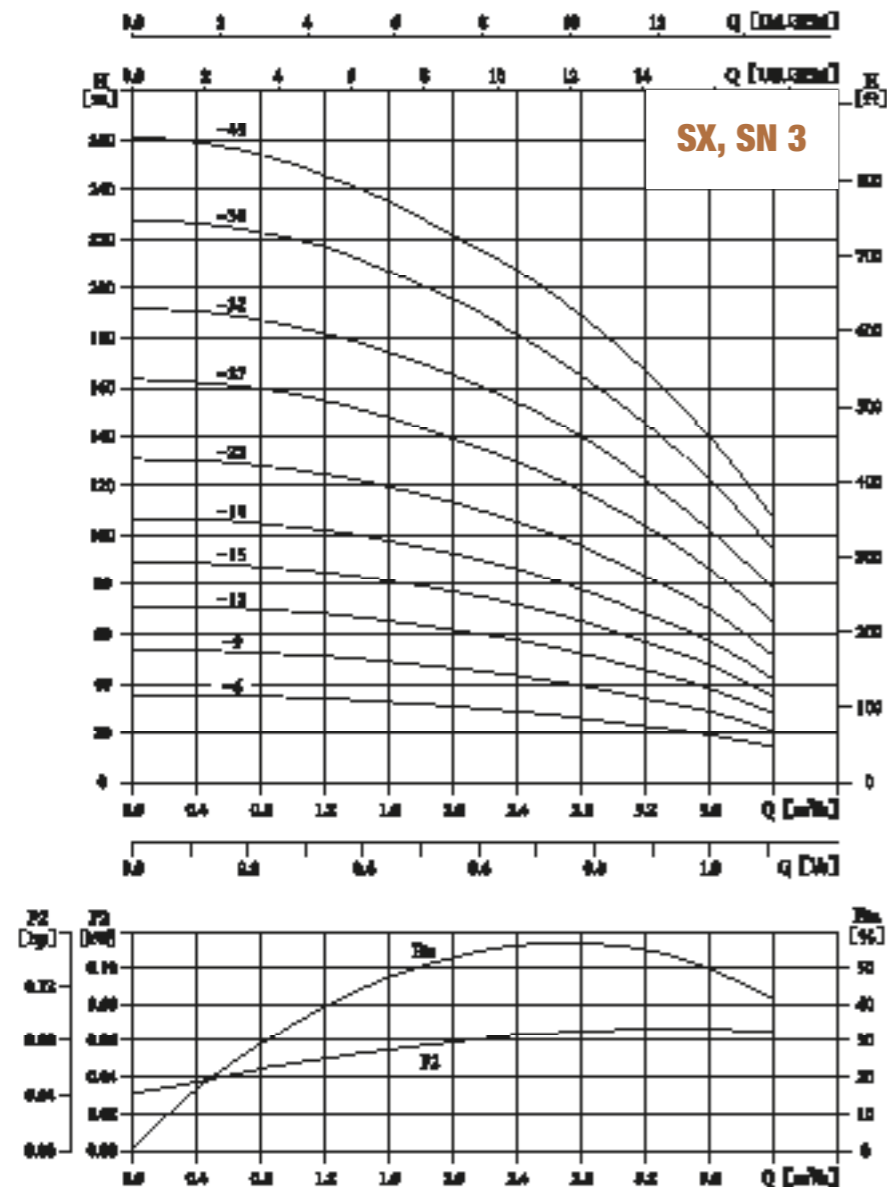

Installation sketch

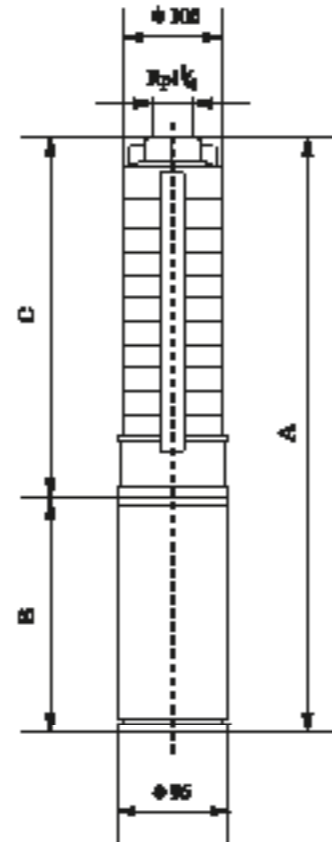

Performance table

Model	Driving motor (kW)		Q (m³/h)	H (m)										
	(kW)	(hp)		0.8	1.2	1.6	2.0	2.4	2.8	3.0	3.2	3.6	4.0	
SX, SN3-6	0.37	0.5		36	34	32	30	28	26	24	23	18	13	
SX, SN3-9	0.55	0.75		53	51	48	45	42	38	36	33	27	20	
SX, SN3-12	0.75	1		70	68	64	61	57	52	49	44	37	27	
SX, SN3-15	1.1	1.5		87	85	81	77	72	65	61	56	47	34	
SX, SN3-18	1.1	1.5		105	103	97	92	87	78	74	68	57	42	
SX, SN3-22	1.5	2		130	126	120	113	106	96	91	84	70	53	
SX, SN3-27	2.2	3		159	154	146	138	130	118	111	104	87	66	
SX, SN3-32	2.2	3		189	183	173	163	154	140	131	122	102	79	
SX, SN3-38	3.0	4		224	217	205	194	183	168	157	146	122	94	
SX, SN3-43	3.0	4		254	246	233	220	207	190	178	166	139	107	

Size and weight

Model	Size (mm)			Weight (kg)
	A	B	C	
SX, SN3-6	667	370	297	12
SX, SN3-9	740	380	360	13
SX, SN3-12	823	400	423	16
SX, SN3-15	926	440	486	18
SX, SN3-18	999	440	549	19
SX, SN3-22	1103	470	633	22
SX, SN3-27	1248	510	738	27
SX, SN3-32	1353	510	843	28
SX, SN3-38	1589	620	969	31
SX, SN3-43	1694	620	1074	32

SX, SN 5

Performance curve ISO9906 Annex A 2850rpm

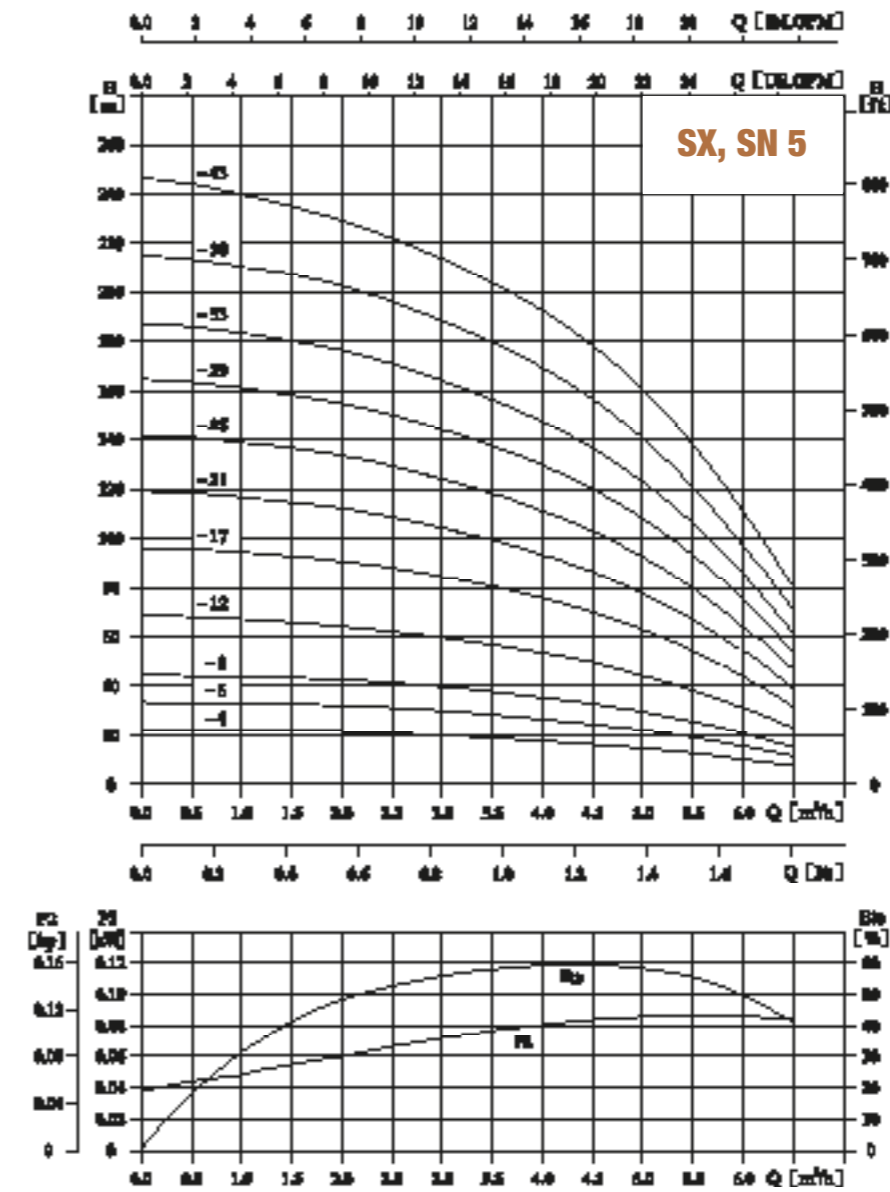

Installation sketch

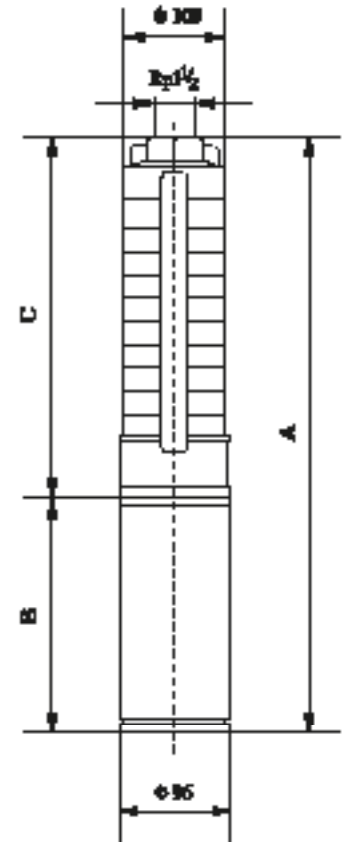

Performance table

Model	Driving motor (kW)		Q (m³/h)	H (m)										
	(kW)	(hp)		1.0	2.0	3.0	3.5	4.0	4.5	5.0	5.5	6.0	6.5	
SX, SN5-4	0.37	0.5		21	20.5	20	19	18	17	15	13	10	6	
SX, SN5-6	0.55	0.75		32	31	30	28	27	25	22	19	15	11	
SX, SN5-8	0.75	1		43	42	40	36	36	33	30	25	20	15	
SX, SN5-12	1.1	1.5		66	63	59	57	54	50	45	38	30	23	
SX, SN5-17	1.5	2		95	91	84	80	76	71	64	54	43	32	
SX, SN5-21	2.2	3		117	112	104	99	94	87	79	67	53	39	
SX, SN5-25	2.2	3		139	134	124	118	112	104	94	80	64	47	
SX, SN5-29	3.0	4		161	155	144	137	130	120	108	92	74	55	
SX, SN5-33	3.0	4		183	177	163	156	148	137	123	105	84	62	
SX, SN5-38	4.0	5.5		211	203	188	178	170	158	142	121	97	71	
SX, SN5-43	4.0	5.5		239	230	213	203	193	179	161	137	109	81	

Size and weight

Model	Size (mm)			Weight (kg)
	A	B	C	
SX, SN5-4	625	370	255	12
SX, SN5-6	677	380	297	13
SX, SN5-8	739	400	339	15
SX, SN5-12	863	440	423	17
SX, SN5-17	998	470	528	21
SX, SN5-21	1122	510	612	26
SX, SN5-25	1206	510	696	27
SX, SN5-29	1400	620	780	29
SX, SN5-33	1484	620	864	30
SX, SN5-38	1719	750	969	33
SX, SN5-43	1824	750	1074	35

SX, SN 8

Performance curve ISO9906 Annex A 2850rpm

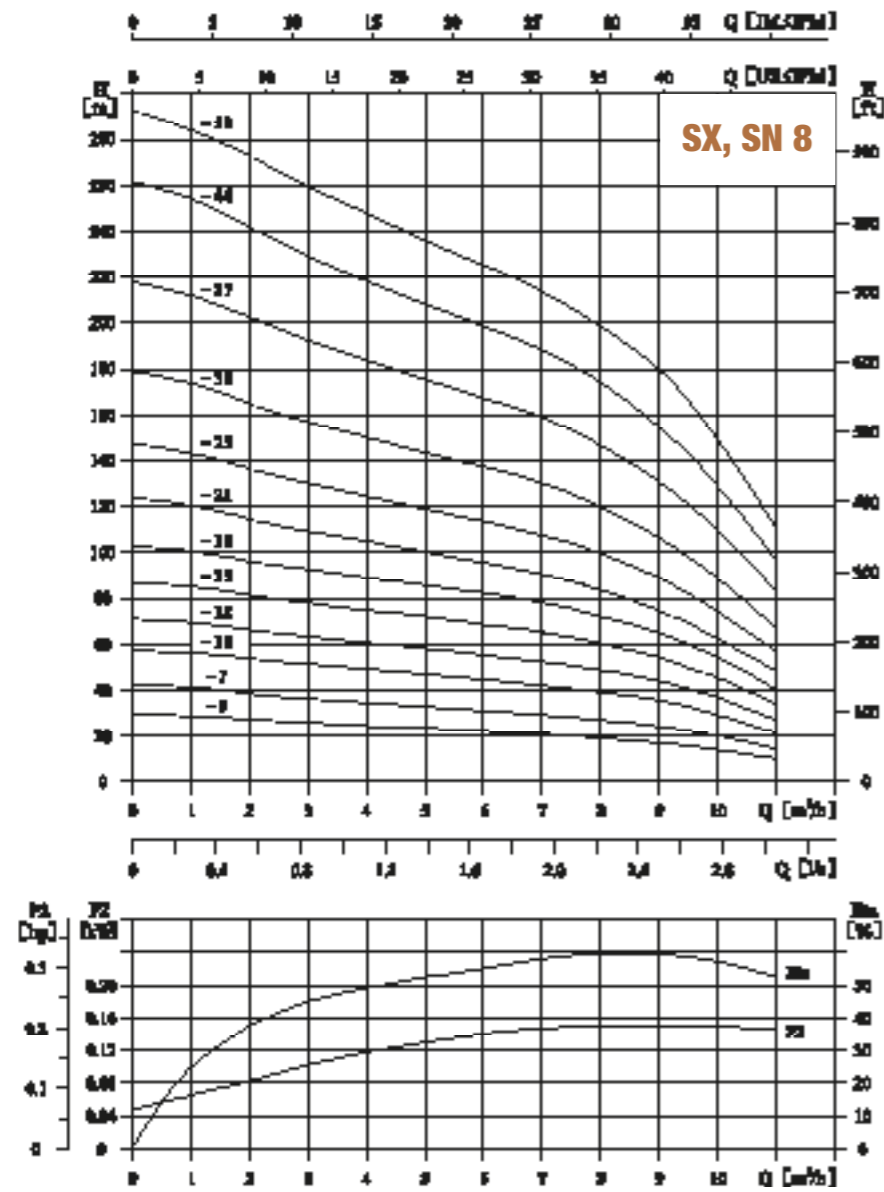

Installation sketch

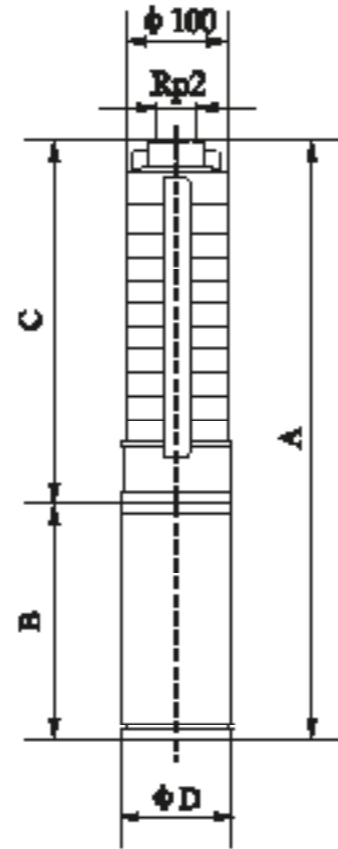

Performance table

Model	Driving motor (kW)		Q (m³/h)	H (m)										
	(kW)	(hp)		2	3	4	5	6	7	8	9	10	11	
SX, SN8-5	0.75	1	H (m)	27	26	24	23	22	21	19	17	14	10	
SX, SN8-7	1.1	1.5		38	36	34	33	31	29	27	24	20	14	
SX, SN8-10	1.5	2		54	52	50	47	45	42	39	35	29	21	
SX, SN8-12	2.2	3		65	62	60	57	54	51	47	42	35	26	
SX, SN8-15	2.2	3		81	77	74	71	68	64	59	53	44	33	
SX, SN8-18	3.0	4		95	93	89	86	81	77	71	63	53	40	
SX, SN8-21	4.0	5.5		112	108	104	100	95	90	83	74	62	47	
SX, SN8-25	4.0	5.5		135	129	124	119	113	108	99	89	74	56	
SX, SN8-30	5.5	7.5		162	155	149	143	136	130	119	106	88	67	
SX, SN8-37	5.5	7.5		201	191	184	176	167	159	147	131	109	62	
SX, SN8-44	7.5	10		242	227	218	209	199	190	174	156	129	98	
SX, SN8-50	7.5	10	272	258	248	238	226	216	198	177	147	111		

Size and weight

Model	Size (mm)				Weight (kg)
	A	B	C	ΦD	
SX, SN8-5	853	400	453	96	16
SX, SN8-7	977	440	537	96	19
SX, SN8-10	1133	470	663	96	22
SX, SN8-12	1257	510	747	96	27
SX, SN8-15	1383	510	873	96	29
SX, SN8-18	1619	620	999	96	32
SX, SN8-21	1875	750	1125	96/143	35/41
SX, SN8-25	2043	750	1293	96/143	37/43
SX, SN8-30	2343	840	1503	96/143	43/51
SX, SN8-37	2637	840	1797	96/143	46/54
SX, SN8-44	3011	920	2091	96/143	55/66
SX, SN8-50	3263	920	2343	96/143	58/69

SX, SN 12

Performance curve ISO9906 Annex A 2850rpm

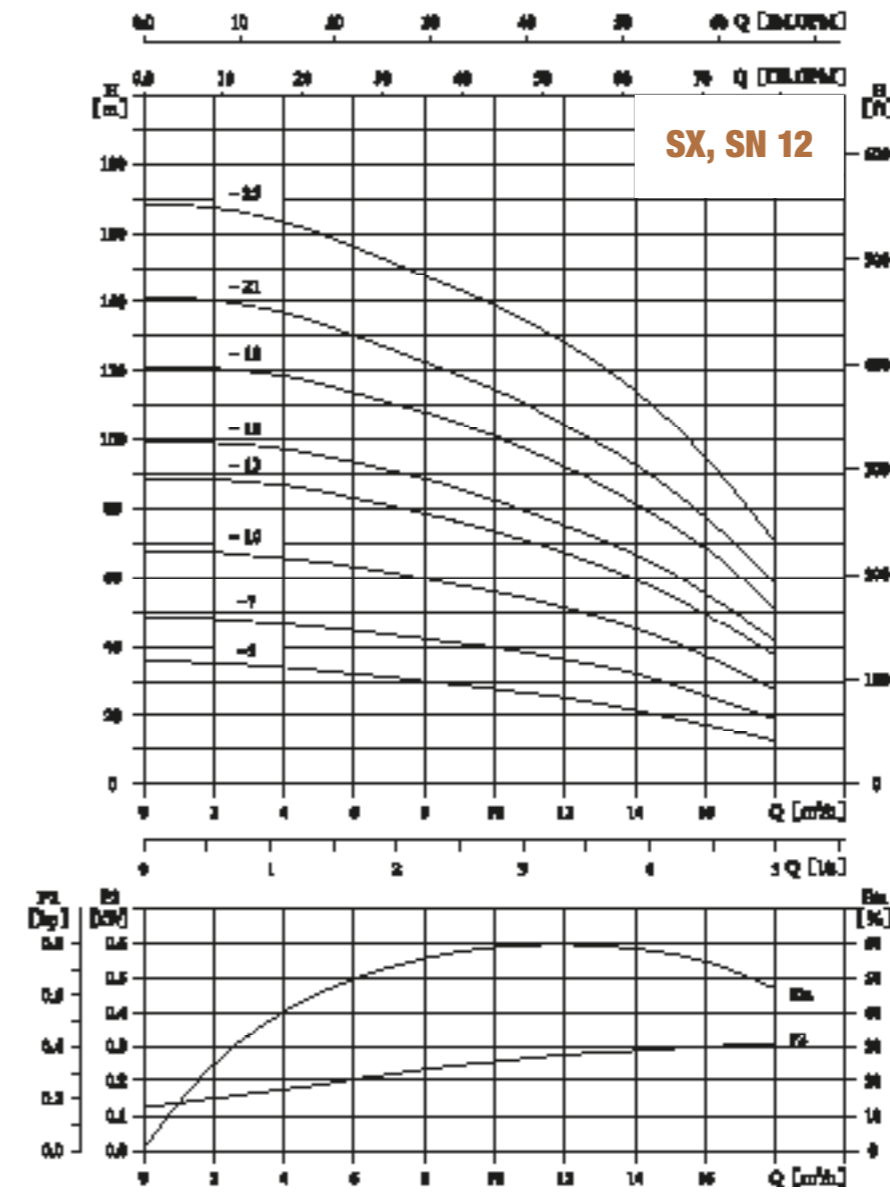

Installation sketch

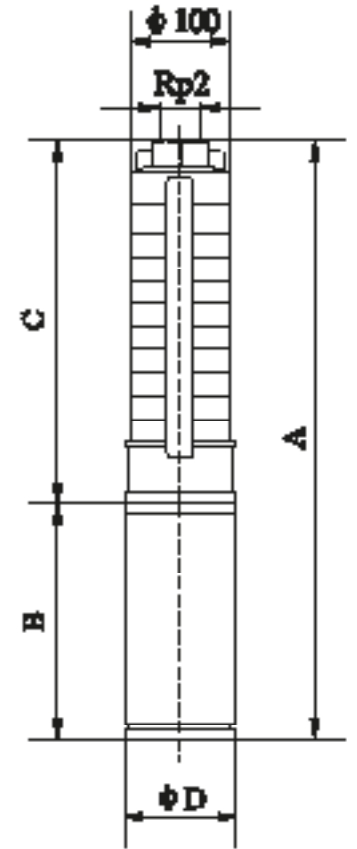

Performance table

Model	Driving motor (kW)		Q (m³/h)	H (m)										
	(kW)	(hp)		3	4	6	8	10	12	14	16	18		
SX, SN12-5	1.5	2	H (m)	34	33	31	29	27	25	22	18	13		
SX, SN12-7	2.2	3		48	46	43	40	38	35	31	25	19		
SX, SN12-10	3.0	4		67	65	62	58	55	50	45	36	27		
SX, SN12-13	4.0	5.5		68	86	81	76	71	66	59	48	36		
SX, SN12-15	5.5	7.5		99	97	93	88	82	76	68	55	41		
SX, SN12-18	5.5	7.5		120	118	112	105	99	91	81	66	50		
SX, SN12-21	7.5	10		138	136	130	123	115	106	95	77	58		
SX, SN12-25	7.5	10		166	163	155	146	137	126	113	92	69		

Size and weight

Model	Size (mm)				Weight (kg)
	A	B	C	ΦD	
SX, SN12-5	1005	470	535	96	21
SX, SN12-7	1175	510	665	96	26
SX, SN12-10	1480	620	860	96	30
SX, SN12-13	1837	782	1055	96/143	34/40
SX, SN12-15	2025	840	1185	96/143	38/46
SX, SN12-18	2220	840	1380	96/143	40/48
SX, SN12-21	2495	920	1575	96/143	47/58
SX, SN12-25	2755	920	1835	96/143	50/61

SX, SN 75

Performance curve ISO9906 Annex A 2850rpm

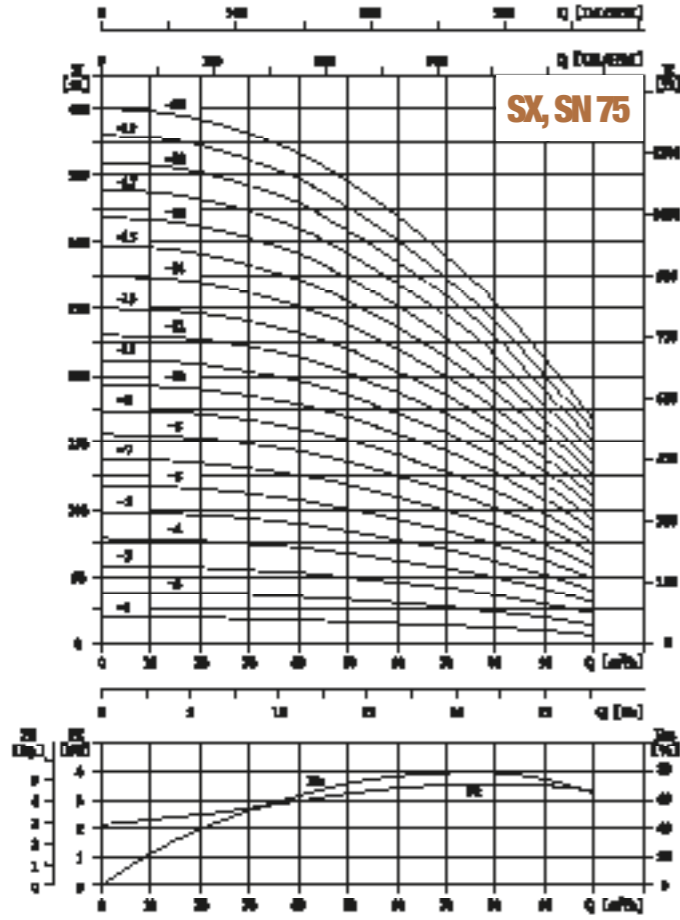

Installation sketch

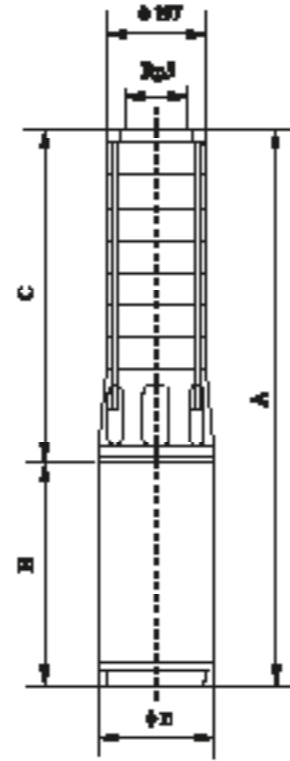

Performance table

Model	Driving motor (kW)		Q (m³/h)	H (m)									
	(kW)	(hp)		30	40	50	60	70	75	80	90	100	
SX,SN75-1	4	5.5	18	17	155	14.5	13	12	11	9	5.5		
SX,SN75-2	7.5	10	36.5	34.5	32	30	27	25	23	19	12.5		
SX,SN75-3	11	15	54.5	52.5	49	45	41	38	35.5	29	21.5		
SX,SN75-4	15	20	73.5	71	66.5	61	55.5	52	48	40	30		
SX,SN75-5	18.5	25	92	89	83	76	70	65	60.5	51	38		
SX,SN75-6	22	30	111	107	100	91	84	79	73	62	47		
SX,SN75-7	30	40	130	125	118	107	98	93	87	73	56		
SX,SN75-8	30	40	148	143	135	124	113	107	101	85	65		
SX,SN75-9	37	50	167	161	152	140	128	121	114	96	74		
SX,SN75-10	37	50	185	178	169	157	143	135	127	107	83		
SX,SN75-11	45	60	203	196	185	172	158	148	139	118	92		
SX,SN75-12	45	60	222	214	202	188	172	162	152	129	100		
SX,SN75-13	55	75	241	232	220	204	186	175	164	139	108		
SX,SN75-14	55	75	262	251	238	220	200	188	176	149	116		
SX,SN75-15	55	75	283	271	256	236	214	201	188	159	124		
SX,SN75-16	63	85	303	291	274	253	229	215	202	169	133		
SX,SN75-17	63	85	323	310	292	270	245	229	215	179	142		
SX,SN75-18	75	100	342	329	309	286	259	243	226	190	150		
SX,SN75-19	75	100	361	347	327	302	274	257	241	201	158		
SX,SN75-20	75	100	381	366	345	318	288	271	254	212	167		

Size and weight

Model	Size (mm)				Weight (kg)
	A	B	C	ΦD	
SX,SN75-1	1270	782	488	143	56
SX,SN75-2	1424/1411	810/780	614/631	143/184	78/97
SX,SN75-3	1660/1577	920/800	740/757	143/184	92/116
SX,SN75-4	1896/1743	1030/860	866/883	143/184	110/134
SX,SN75-5	2082/1899	1090/890	992/1009	143/184	122/152
SX,SN75-6	2278/2075	1160/940	1118/1135	143/184	141/178
SX,SN75-7	2574/2311	1330/1050	1244/1261	143/184	171/211
SX,SN75-8	2700/2437	1330/1050	1370/1387	143/184	176/216
SX,SN75-9	3066/2663	1570/1150	1496/1513	143/184	204/233
SX,SN75-10	3192/2789	1570/1150	1622/1639	143/184	209/238
SX,SN75-11	3005	1240	1765	184	256
SX,SN75-12	3131	1240	1891	184	261
SX,SN75-13	3387	1370	2017	184	279
SX,SN75-14	3513	1370	2143	184	285
SX,SN75-15	3639	1370	2269	184	290
SX,SN75-16	3885	1490	2395	192	309
SX,SN75-17	4011	1490	2521	192	315
SX,SN75-18	4187	1540	2647	192	341
SX,SN75-19	4313	1540	2773	192	346
SX,SN75-20	4439	1540	2899	192	351

SX, SN 95

Performance curve ISO9906 Annex A 2850rpm

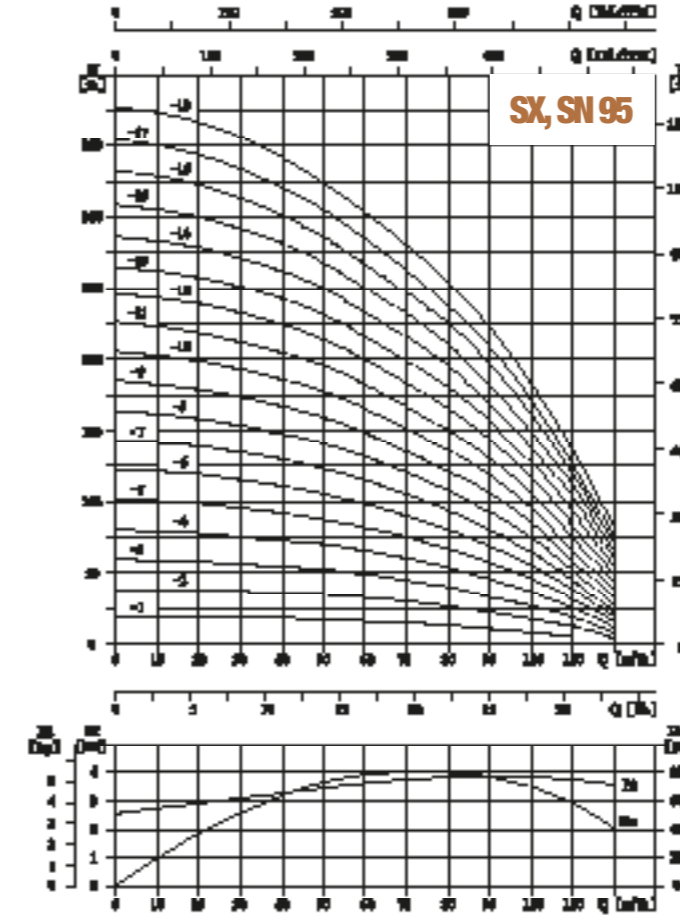

Installation sketch

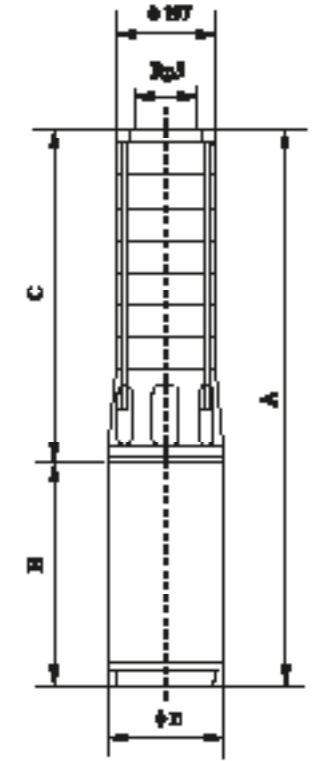

Performance table

Model	Driving motor (kW)		Q (m³/h)	H (m)									
	(kW)	(hp)		40	50	60	70	80	90	95	100	110	120
SX,SN95-1	4	5.5	17.5	16.5	15.5	14	12.5	10.5	9.5	8	5	—	
SX,SN95-2	9.2	12.5	36	34	32	28.5	26	21.5	20	17	12	3.5	
SX,SN95-3	13	17.5	54	52	48.5	44.5	40	33	30	26	19	6	
SX,SN95-4	18.5	25	72	70	65	60	54	45	41	36	25.5	10.5	
SX,SN95-5	22	30	91	87	81.5	75	68	57	51.5	46	32	14.5	
SX,SN95-6	25	34	110	104	98	90	81	69	62	55	38	16	
SX,SN95-7	30	40	129	122	115	105	94	81	73	65	45	22	
SX,SN95-8	37	50	148	141	131	120	108	93	84	75	52	26	
SX,SN95-9	37	50	167	159	148	135	122	105	95	85	59	31	
SX,SN95-10	45	60	186	177	165	151	136	117	106	95	67	36	
SX,SN95-11	45	60	205	195	182	167	150	130	117	105	75	42	
SX,SN95-12	55	75	224	213	199	183	165	143	129	116	84	48	
SX,SN95-13	55	75	243	231	216	199	180	156	141	127	93	53	
SX,SN95-14	55	75	262	249	233	215	195	169	153	138	102	59	
SX,SN95-15	63	85	281	268	250	231	210	183	166	149	111	64	
SX,SN95-16	63	85	301	286	267	247	225	197	178	160	119	70	
SX,SN95-17	75	100	321	304	284	263	240	210	190	171	127	75	
SX,SN95-18	75	100	342	323	302	279	255	222	202	182	135	61	

Size and weight

Model	Size (mm)				Weight (kg)
	A	B	C	ΦD	
SX,SN95-1	1270	782	488	143	57
SX,SN95-2	1484/1431	870/800	614/631	143/184	83/105
SX,SN95-3	1720/1617	980/860	740/757	143/184	100/129
SX,SN95-4	1956/1773	1090/890	866/883	143/184	119/148
SX,SN95-5	2152/1949	1160/940	992/1009	143/184	138/175
SX,SN95-6	2348/2125	1230/990	1116/1135	143/184	155/188
SX,SN95-7	2574/2311	1330/1050	1244/1261	143/184	174/213
SX,SN95-8	2940/2537	1570/1150	1370/1387	143/184	202/231
SX,SN95-9	3066/2663	1570/1150	1496/1513	143/184	208/237
SX,SN95-10	2879	1240	1639	184	254
SX,SN95-11	3005	1240	1765	184	260
SX,SN95-12	3261	1370	1891	184	279
SX,SN95-13	3387	1370	2017	184	284
SX,SN95-14	3513	1370	2143	184	290
SX,SN95-15	3759	1490	2269	192	310
SX,SN95-16	3885	1490	2395	192	316
SX,SN95-17	4061	1540	2521	192	342
SX,SN95-18	4187	1540	2647	192	348

SX, SN 120

Performance curve ISO9906 Annex A 2850rpm

Installation sketch

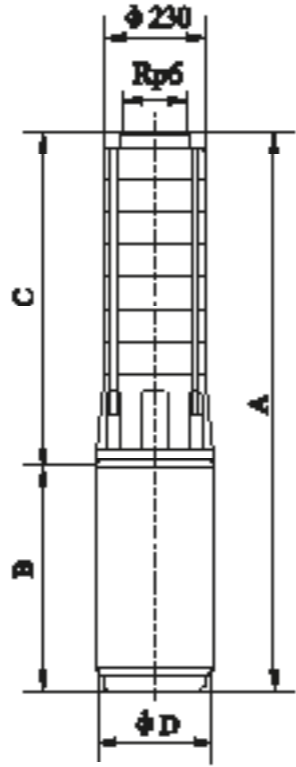
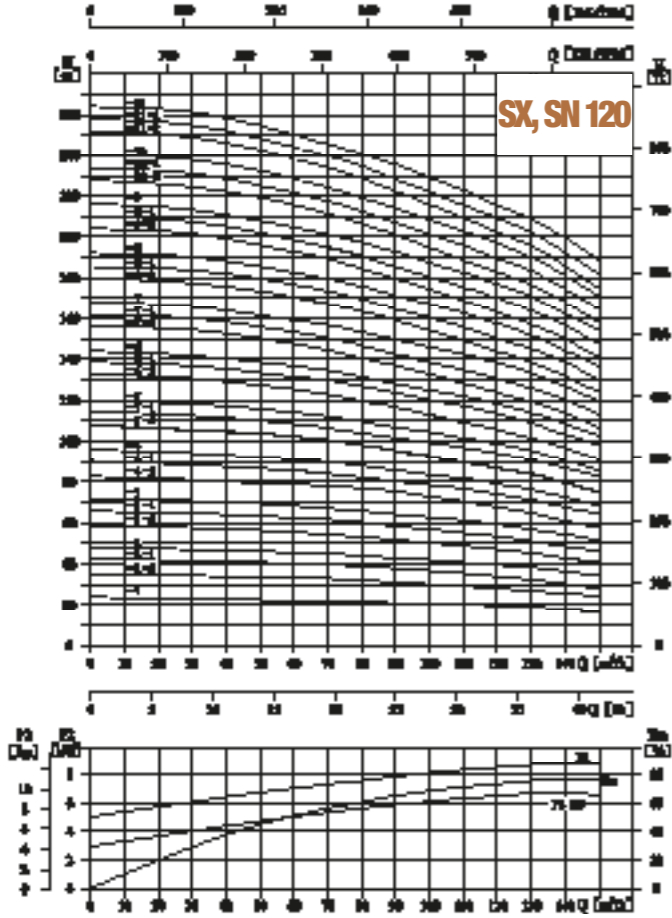

Performance table

Model	Driving motor (kW)		Q (m³/h)	H (m)												
	(kW)	(hp)		60	70	80	90	100	110	120	130	140	150			
SX, SN120-1	11	15	22.5	22	21.5	21	20.5	20	19	18.5	17.5	16.5				
SX, SN120-2-2	15	20	33.5	33	32	30	29	28.5	27.5	26.5	24.5	24				
SX, SN120-2-1	18.5	25	40.5	40	38.5	37.5	36	35.5	33.5	32.5	29.5	28				
SX, SN120-2	22	30	45.5	44.5	43.5	42.5	41.5	40.5	39	38	36	34				
SX, SN120-3-2	25	34	55	54.5	52.5	51	49.5	48.5	46.5	45	42.5	40.5				
SX, SN120-3-1	30	40	62.5	61.5	60	58	56	54	53.5	51	48.5	46				
SX, SN120-3	30	40	66	67	65.5	64	62	61	59	57	54	51				
SX, SN120-4-2	37	50	78.5	77	75	72.5	70.5	69	66.5	65	60.5	57.5				
SX, SN120-4-1	37	50	85	84	82	79.5	77	76	73.5	71	67	64				
SX, SN120-4	37	50	90.5	89.5	87.5	85.5	83	81.5	78.5	76	72	68				
SX, SN120-5-2	45	60	102	100.5	97.5	95	91.5	90	86.5	84	79	74.5				
SX, SN120-5-1	45	60	108.5	106.5	103.5	101	98.5	96.5	94	91	86.5	82				
SX, SN120-5	55	75	113.5	112	109.5	106.5	103.5	101.5	98.5	95	90	85				
SX, SN120-6-2	55	75	125	122.5	119	116.5	112.5	109	104.5	101.5	96	90.5				
SX, SN120-6-1	55	75	131	129.5	125.5	123.5	120	117	113	109	103	96				
SX, SN120-6	63	85	136	134.5	131	127.5	124.5	121.5	118	114	108	102				
SX, SN120-7-2	63	85	147	144	140.5	136.5	132.5	128	123	119	113	106				
SX, SN120-7-1	63	85	153	150	146.5	142.5	138.5	135	130	125.5	120	112.5				
SX, SN120-7	75	100	159	156.5	153	149	145	142	138	133	126	119.5				
SX, SN120-8-2	75	100	170	167	164.5	158	153	148.5	143	138	131.5	123				
SX, SN120-8-1	75	100	175.5	173	168.5	163.5	159	158.5	150	145	138	129.5				
SX, SN120-8	75	100	181.5	179.5	175	170.5	166	163	157.5	152.5	144	136.5				
SX, SN120-9-2	90	120	192.5	189	184	179.5	174	168.5	162.5	157	149.5	140				
SX, SN120-9-1	90	120	198	195	190.5	185	180	175.5	169.5	164	156	147				
SX, SN120-9	90	120	204	201.5	198	191.5	186.5	182.5	177.5	171.5	162	153.5				
SX, SN120-10-2	90	120	215.5	211	206	200.5	194.5	188.5	182.5	176.5	167.5	157.5				
SX, SN120-10-1	90	120	221	217	212	206.5	200.5	195.5	189.5	183	174	164				
SX, SN120-10	110	150	227	223.5	219	213	207.5	202.5	197	190.5	180	170.5				
SX, SN120-11-2	110	150	238	233	228	222	215.5	208	202	195.5	185.5	174.5				
SX, SN120-11-1	110	150	243.5	239.5	234	227.5	221.5	215	209	202	192	181				
SX, SN120-11	110	150	250	245.5	241	234.5	228	222.5	216.5	209.5	198.5	187.5				

Size and weight

Model	Size (mm)				Weight (kg)
	A	B	C	ΦD	
SX, SN120-1	1451/1380/-	920/820/-	531/560/-	144/184/-	96/121/-
SX, SN120-2-2	1721/1580/-	1030/860/-	691/720/-	144/184/-	111/135/-
SX, SN120-2-1	1781/1610/-	1090/890/-	691/720/-	144/184/-	118/140/-
SX, SN120-2	1921/1660/-	1230/940/-	691/720/-	144/184/-	127/155/-
SX, SN120-3-2	2093/1870/-	1242/990/-	851/880/-	144/184/-	142/173/-
SX, SN120-3-1	2233/1930/2002	1382/1050/1122	851/880/880	144/184/236	148/187/227
SX, SN120-3	2233/1930/2002	1362/1050/1122	851/880/880	144/184/236	148/187/227
SX, SN120-4-2	2581/2190/2202	1570/1150/1162	1011/1040/1040	144/184/236	166/210/252
SX, SN120-4-1	2581/2190/2202	1570/1150/1162	1011/1040/1040	144/184/236	166/210/252
SX, SN120-4	2581/2190/2202	1570/1150/1162	1011/1040/1040	144/184/236	166/210/252
SX, SN120-5-2	-/2440/2392	-/1240/1192	-/1200/1200	-/184/236	-/233/262
SX, SN120-5-1	-/2440/2392	-/1240/1192	-/1200/1200	-/184/236	-/233/262
SX, SN120-5	-/2570/2472	-/1370/1272	-/1200/1200	-/184/236	-/253/215
SX, SN120-6-2	-/2730/2632	-/1370/1272	-/1360/1360	-/184/236	-/261/323
SX, SN120-6-1	-/2730/2632	-/1370/1272	-/1360/1360	-/184/236	-/261/323
SX, SN120-6	-/2650/2692	-/1490/1332	-/1360/1360	-/192/236	-/288/341
SX, SN120-7-2	-/3010/2852	-/1490/1332	-/1520/1520	-/192/236	-/296/349
SX, SN120-7-1	-/3010/2852	-/1490/1332	-/1520/1520	-/192/236	-/296/349
SX, SN120-7	-/3060/2942	-/1540/1422	-/1520/1520	-/192/236	-/306/387
SX, SN120-8-2	-/3220/3102	-/1540/1422	-/1680/1680	-/192/236	-/314/395
SX, SN120-8-1	-/3220/3102	-/1540/1422	-/1680/1680	-/192/236	-/314/395
SX, SN120-8	-/3220/3102	-/1540/1422	-/1680/1680	-/192/236	-/314/395
SX, SN120-9-2	-/3484/3371	-/1644/1531	-/1840/1840	-/192/236	-/342/416
SX, SN120-9-1	-/3484/3371	-/1644/1531	-/1840/1840	-/192/236	-/342/416
SX, SN120-9	-/3484/3371	-/1644/1531	-/1840/1840	-/192/236	-/342/416
SX, SN120-10-2	-/3644/3531	-/1644/1531	-/2000/2000	-/192/236	-/350/424
SX, SN120-10-1	-/3544/3531	-/1644/1531	-/2000/2000	-/192/236	-/350/424
SX, SN120-10	-/3764/3641	-/1764/1641	-/2000/2000	-/192/236	-/376/461
SX, SN120-11-2	-/3924/3801	-/1764/1641	-/2160/2160	-/192/236	-/384/469
SX, SN120-11-1	-/3924/3801	-/1764/1641	-/2160/2160	-/192/236	-/384/469
SX, SN120-11	-/3924/3801	-/1764/1641	-/2160/2160	-/192/236	-/384/469

SX, SN 150

Performance curve ISO9906 Annex A 2850rpm

Installation sketch

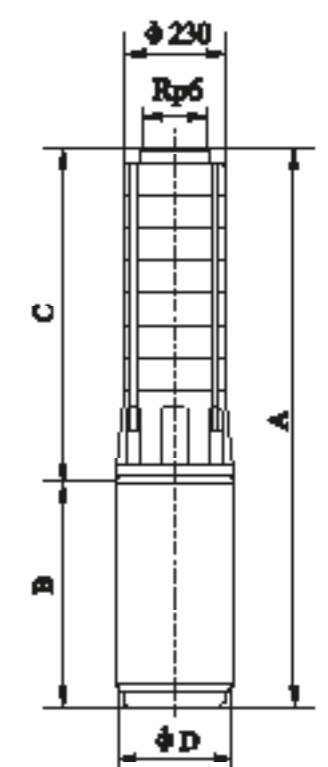
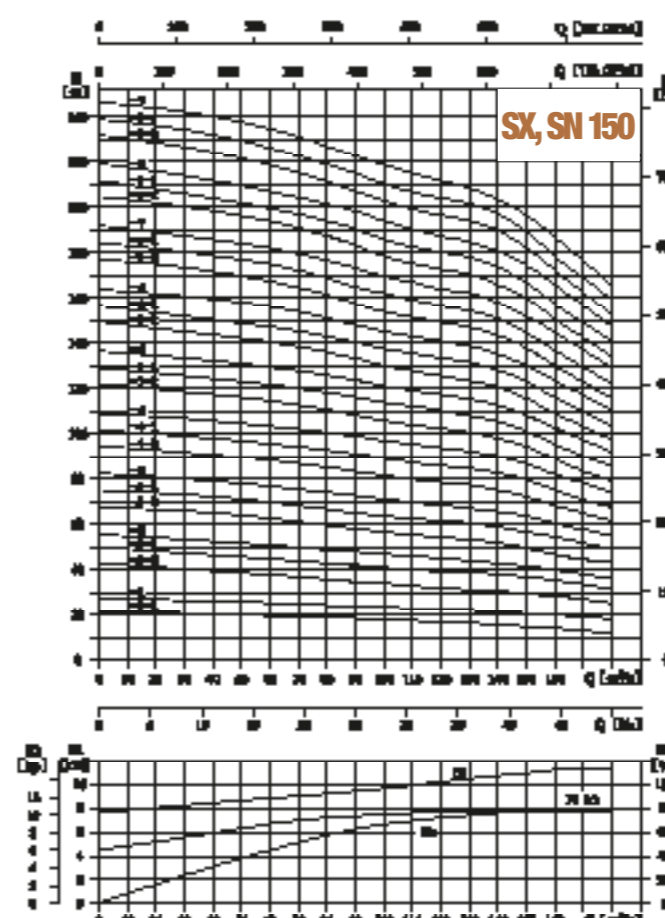

Performance table

Model	Driving motor (kW)		Q (m³/h)	H (m)												
	(kW)	(hp)		80	90	100	110	120	130	140	150	160	170	180		
SX, SN150-1-1	9.2	12.5	18.5	18	17.5	17	16.5	16	15	14.5	13.5	13	11.5			
SX, SN150-1	13	17.5	24	23.5	23	22.5	22	21.5	21	20	19.5	19	16			
SX, SN150-2-2	18.5	25	35.5	34	32	31.5	31	29.5	29	28.5	28	27	25			
SX, SN150-2-1	22	30	43	41.5	40	39	38.5	38	37.5	36	35.5	34	31			
SX, SN150-2	25	34	48.5	47.5	46	45	44.5	44	42.5	41	39.5	38	36			
SX, SN150-3-2	30	40	60	57	54.5	54	53.5	53	52.5	49.5	46.5	44.5	43			
SX, SN150-3-1	37	50	66.5	64	62.5	61.5	60.5	60	59.5	56.5	54	51.5	49			
SX, SN150-3	37	50	74.5	72.5	70.5	69.5	66	67.5	65.5	63.5	60	57.5	54.5			
SX, SN150-4-2	45	60	85.5	83	80	79	77.5	77	76	73	66.5	63.5	61			
SX, SN150-4-1	45	60	93	90	87.5	86.5	84.5	83.5	83	79.5	73.5	70.5	67			
SX, SN150-4	55	75	100.5	98	96	94.5	93	92.5	89.5	86.5	80.5	77.5	73			
SX, SN150-5-2	55	75	111.5	107	104	103	102	101	98	94	66.5	61.5	58.5			
SX, SN150-5-1	55	75	118.5	114.5	112	110.5	108.5	107	105.5	101	94	89.5	85			
SX, SN150-5	63	85	126	122.5	120	118	116	115	112.5	108.5	101.5	97	91.5			
SX, SN150-6-2	63	85	137	131.5	128	126.5	123	122	120.5	115.5	107	101	97			
SX, SN150-6-1	75	100	144	139	136	134	132	131.5	128	122.5	114.5	109	103.5			
SX, SN150-6	75	100	151.5	147	144	141.5	139.5	136	135	130	122	116.5	110			
SX, SN150-7-2	75	100	162.5	156	152.5	150.5	146	145	143	138	126	121	115			
SX, SN150-7-1	90	120	169.5	163.5	160.5	158	155	153	150.5	145	135.5	129	121.5			
SX, SN150-7	90	120	177	171.5	168.5	165.5	163.5	162.5	157.5	152.5	143	136.5	128			
SX, SN150-8-2	90	120	188	180.5	177	174.5	172	171	165.5	160.5	149	140.5	133.5			
SX, SN150-8-1	110	150	195	188	185	182	180	178.5	173	168.5	156.5	148.5	140			
SX, SN150-8	110	150	202.5	196	193	189.5	187	186	180	175	164	156	146.5			
SX, SN150-9-2	110	150	213.5	205	201.5	198	196	194	188.5	182.5	170.5	160	152			
SX, SN150-9-1	110	150	220.5	212.5	209.5	205.5	203	201.5	196	189.5	178	166	158.5			
SX, SN150-9	110	150	228	220.5	217.5	213	210	209	203	197	185.5	175.5	165			

Size and weight

Model	Size (mm)				Weight (kg)
	A	B	C	ΦD	
SX, SN150-1-1	1428/1360/-	897/800/-	531/560/-	144/148/-	92/117/-
SX, SN150-1	1561/1420/-	1030/860/-	531/560/-	144/148/-	100/124/-
SX, SN150-2-2	1781/1610/-	1090/890/-	691/720/-	144/148/-	119/141/-
SX, SN150-2-1	1851/1660/-	1160/940/-	691/720/-	144/148/-	128/156/-
SX, SN150-2	1933/1710/-	1242/990/-	691/720/-	144/148/236	135/166/-
SX, SN150-3-2	2233/1930/2002	1382/1050/1122	851/880/880	144/184/236	149/188/228
SX, SN150-3-1	2421/2030/2042	1570/1150/1162	851/880/880	144/184/236	158/202/246
SX, SN150-3	2421/2030/2042	1570/1150/1162	851/880/880	144/134/236	158/202/246
SX, SN150-4-2	-/2280/2232	-/1240/			

SX, SN 200

Performance curve ISO9906 Annex A 2850rpm

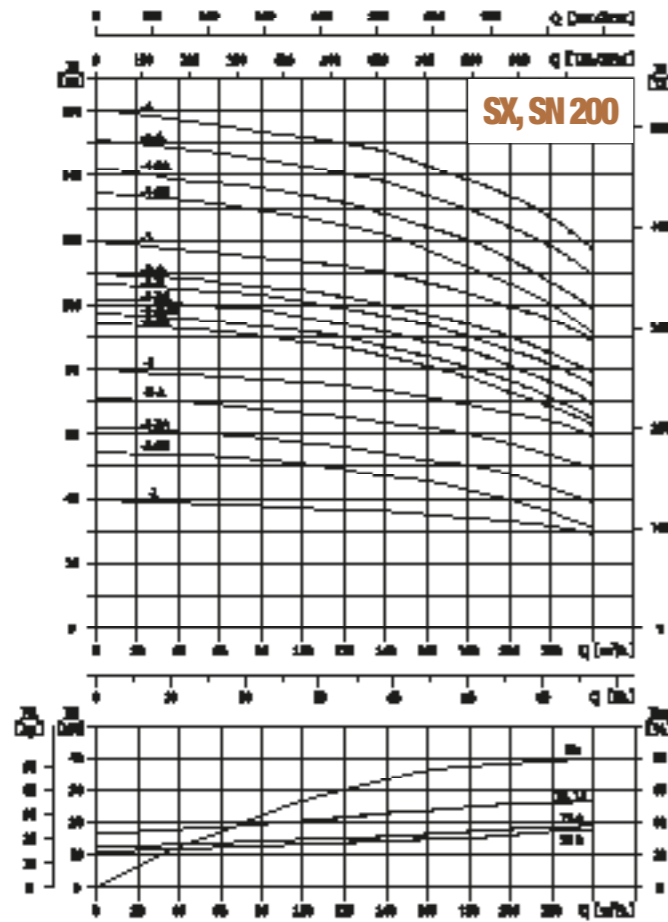

Installation sketch

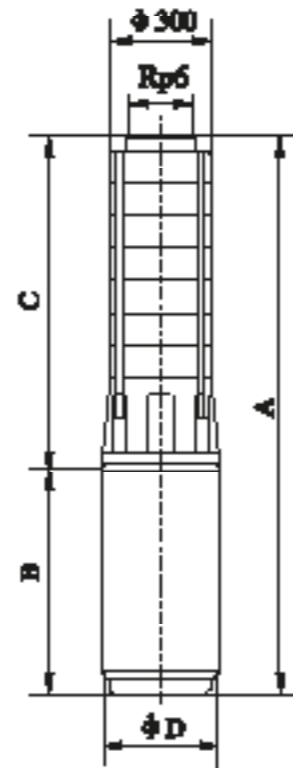

Performance table

Model	Driving motor (kW)		Q (m³/h)	H (m)								
	(kW)	(hp)		100	120	140	160	180	200	220	240	
SX, SN200-1	30	40		37	36.5	36	35	34	33	31.5	29	
SX, SN200-2-2B	37	50		51	49	47	45.5	42.5	39.5	35.5	31	
SX, SN200-2-2A	45	60		57.5	56	54	52	50.5	47.5	43	39	
SX, SN200-Z-A	55	75		66.5	65.5	63.5	62	60	57	53.5	49.5	
SX, SN200-Z	55	75		76	75	73.5	71.5	69	66.5	64	59.5	
SX, SN200-3-2B	75	100		68.5	87	84	81	78	72.5	68.5	63	
SX, SN200-3-A-B	75	100		92	90	87	84	80.5	76.5	71	65	
SX, SN200-3-2A	75	100		96	94	91.5	88.5	86	81	76	69.5	
SX, SN200-3-B	75	100		101	99	96.5	94	90	86	81.5	109.5	
SX, SN200-3-A	75	100		104.5	102.5	100	97	94	90	85	75	
SX, SN200-3	90	120		113.5	112	110	107	103.5	99.5	95.5	79	
SX, SN200-4-2B	90	120		127	124.5	121.5	117	111.5	106.5	100	89	
SX, SN200-4-2A	110	150		134	131.5	127.5	124	120	114	107	91	
SX, SN200-4-A	110	150		143	140.5	138	133.5	129.5	124	118	99	
SX, SN200-4	110	150		152	150	147.5	143	136.5	133.5	127	117	

Size and weight

Model	Size (mm)				Weight (kg)
	A	B	C	ΦD	
SX, SN17-1	708	380	328	96	17
SX, SN17-2	828	440	388	96	21
SX, SN17-3	959	510	449	96	28
SX, SN17-4	1019	510	509	96	29
SX, SN17-S	1190	620	570	96	32
SX, SN17-6	1412	782	630	96/143	35/41
SX, SN17-7	1441	782	691	96/143	36/42
SX, SN17-8	1591	840	751	96/143	41/49
SX, SN17-9	1652	840	812	96/143	42/50
SX, SN17-10	1712	840	872	96/143	43/51
SX, SN17-11	1853	920	933	96/143	49/60
SX, SN17-12	1913	920	993	96/143	50/61
SX, SN17-13	1974	920	1054	96/143	51/62
SX, SN17-14	2027	897	1130	143	75
SX, SN17-15	2088	897	1191	143	76



HY04

4" Rewindable Oil filled Submersible motors

4" Rewindable Oil Filled Submersible Motors

Motors designed to work in 4" or wider wells. The use of very high quality Made in Italy materials and our strict tests together with consolidated know how ensure high mechanical resistance and high performing electric features.

All parts in contact with water are in AISI 304 stainless steel. The power cable with removable connector ensures perfect water-tightness.

Product features

External sleeve and bottom:

Made in AISI 304 stainless steel. More specifically, sleeve is made of AISI 304L (Low carbon) to avoid possible corrosions on the welding.

Upper Bracket:

Cast iron with cataphoresis treatment and protected with an AISI 304 stainless steel cover. Sleeve clamping is ensured by 4 inserts in low power motors and 6 inserts in motors bigger than 3Hp.

Mechanical Seal:

Graphite/ceramic in the standard version; SIC-SIC version available upon request.

Ball Bearings:

Duly oversized to ensure a long lasting motor.

Stator:

With 24 slots, specifically developed to achieve maximum electrical yield. Airtight sealed and immersed in selected mineral white and highly refined oil, suitable to be used in drinking water (F.D.A., Food and Drug Administration, approved)

Removable Power Cable-Connector:

It ensures perfect sealing in the most critical conditions and it aids maintenance operations. More specifically, the connector prevents oil from rising in the conductors up to the joint, thus enabling immersion at greater depths. The power cable complies with all major standards on the use in drinking water (KTW, ACS, WRAS).

Shaft:

Carbon-steel alloys in the rotor area, to foster electrical features. AISI 304 stainless steel projection. DUPLEX, a special type of stainless steel, replaces AISI 304 in motors bigger than 3Hp. This steel combines excellent resistance to corrosion and high mechanical resistance, which is necessary where static torque becomes really important.

100% tested:

All motors are tested at the end of the line. An extremely effective seal check is also carried out on all motors.



Single phase submersible motors 50Hz 230v oil filled

Type	P ₂ [Hp]	P ₂ [kW]	Voltage [V]	Ph	I _n [A]	I _{avv} [A]	rpm	φ cos	η [%]	Capacitor [μF]	Thrust load [N]	Length A [mm]	Weight [kg]	Cable section [mm ²]	Cable Length [m]
HYO4-037S230	0,5	0,37	230	1	3,6	12	2810	0,87	52	20	2000	311,3	6,45	4 x 1,5	1,7
HYO4-055S230	0,75	0,55	230	1	4,7	16,5	2810	0,88	57	25	2000	331,3	7,2	4 x 1,5	1,7
HYO4-075S230	1	0,75	230	1	5,9	18,9	2825	0,9	62	35	2000	356,3	8,45	4 x 1,5	1,7
HYO4-110S230	1,5	1,1	230	1	8,3	26,2	2840	0,91	64	40	2000	386,3	10,2	4 x 1,5	1,7
HYO4-150S230	2	1,5	230	1	10,7	35	2845	0,93	66	60	2000	436,3	11,65	4 x 1,5	1,7
HYO4-220S230	3	2,2	230	1	15,2	47	2820	0,93	67	80	2000	481,3	14,9	4 x 1,5	1,7
HYO4-370S230	5	3,7	230	1	24,5	95	2810	0,95	73	10+315/400	5000	699,5	24,15	4 x 2	2,7

Three phase submersible motors 50Hz 230v oil filled

Type	P ₂ [Hp]	P ₂ [kW]	Voltage [V]	Ph	I _n [A]	I _{avv} [A]	rpm	φ cos	η [%]	Capacitor [μF]	Thrust load [N]	Length A [mm]	Weight [kg]	Cable section [mm ²]	Cable Length [m]
HYO4-037T230	0,5	0,37	230	3	2,2	8,9	2855	0,75	57	-	2000	311,3	6,45	4 x 1,5	1,7
HYO4-055T230	0,75	0,55	230	3	3,4	13,5	2830	0,70	62	-	2000	331,3	7,2	4 x 1,5	1,7
HYO4-075T230	1	0,75	230	3	4,1	15,5	2820	0,74	62	-	2000	356,3	8,45	4 x 1,5	1,7
HYO4-110T230	1,5	1,1	230	3	5,9	25	2825	0,68	68	-	2000	371,3	9,35	4 x 1,5	1,7
HYO4-150T230	2	1,5	230	3	8,2	27,5	2830	0,64	70	-	2000	386,3	10,2	4 x 1,5	1,7
HYO4-220T230	3	2,2	230	3	10,6	39,5	2815	0,70	72	-	2000	436,3	11,65	4 x 1,5	1,7
HYO4-300T230	4	3	230	3	12,8	39,5	2830	0,81	75	-	3000	481,3	14,9	4 x 1,5	1,7
HYO4-400T230	5,5	4	230	3	15,6	86	2840	0,83	76	-	5000	609,5	20,05	4 x 2	2,7
HYO4-550T230	7,5	5,5	230	3	22,7	109	2825	0,78	79	-	5000	699,5	24,65	4 x 2	2,7

Three phase submersible motors 50Hz 400v oil filled

Type	P ₂ [Hp]	P ₂ [kW]	Voltage [V]	Ph	I _n [A]	I _{avv} [A]	rpm	φ cos	η [%]	Capacitor [μF]	Thrust load [N]	Length A [mm]	Weight [kg]	Cable section [mm ²]	Cable Length [m]
HYO4-037T400	0,5	0,37	400	3	1,8	5,8	2850	0,54	58	-	2000	311,3	6,45	4 x 1,5	1,7
HYO4-055T400	0,75	0,55	400	3	2	8	2835	0,65	63	-	2000	331,3	7,2	4 x 1,5	1,7
HYO4-075T400	1	0,75	400	3	2,5	9,4	2825	0,77	63	-	2000	356,3	8,45	4 x 1,5	1,7
HYO4-110T400	1,5	1,1	400	3	3,4	15,5	2825	0,69	68	-	2000	371,3	9,35	4 x 1,5	1,7
HYO4-150T400	2	1,5	400	3	4,8	18	2835	0,63	71	-	2000	386,3	10,2	4 x 1,5	1,7
HYO4-220T400	3	2,2	400	3	6,1	39,5	2810	0,69	72	-	2000	436,3	11,65	4 x 1,5	1,7
HYO4-300T400	4	3	400	3	7,1	39,5	2835	0,69	75	-	3000	481,3	14,9	4 x 1,5	1,7
HYO4-400T400	5,5	4	400	3	9,2	49,5	2845	0,83	76	-	5000	609,5	20,05	4 x 2	2,7
HYO4-550T400	7,5	5,5	400	3	11,7	64	2835	0,86	79	-	5000	699,5	24,65	4 x 2	2,7
HYO4-750T400	10	7,5	400	3	16,4	88	2840	0,81	81	-	5000	799,5	28,95	4 x 2	2,7

Technical Specifications

Motor/Pump Flange	4" Nema Standard
Degree of protection	IP 68
Insulation Class	F
Voltage tolerance	- 10% / + 10%
Pumped liquid temperature	0°C - 35°C 32°F - 95°F
Min. Cooling Flow	0,1 m/s 0,328 ft/s
Max. Starts / Hour	30
Mounting	Vertical And/Or Horizontal
Max. Immersion Depth	200M
Thrust Load	
From 0,5 to 3 Hp	2000N
From 3 to 4 Hp	3000N
From 5,5 to 10 Hp	5000N

Single Phase Version: Psc Type
(Permanent Split Capacitor)

Rewindable Motor Version

Cables, Voltage, Thrust Loads [...]
Special Versions Available.



HYA4

4" Water cooled Submersible motors Canned type

4" Water cooled submersible motors, canned type

Motors designed to work in 4" or wider wells. The use of very high quality Made in Italy materials and our strict tests together with consolidated know how ensure high mechanical resistance and high performing electrical features. All parts in contact with water are in AISI 304 stainless steel which ensures resistance to corrosion even in the most extreme conditions of use.

Shaft:

Carbon-steel alloys in the rotor area, to foster electrical features. AISI 304 stainless steel projection. DUPLEX, a special type of stainless steel, replaces AISI 304 in motors bigger than 3Hp. This steel combines excellent resistance to corrosion and high mechanical resistance, which is necessary where static torque becomes really important.

Product features

SStator:

With 24 slots, specially developed to achieve maximum electrical performance. Airtight sealed and resin encapsulated. A solution which ensures excellent heat exchange and extremely high mechanical resistance with high pressure, something typical of very deep immersions.

Removable Power Cable-Connector:

It ensures perfect sealing in the most critical conditions and it aids maintenance operations. The power cable complies with all major standards on the use in drinking water (KTW, ACS, WRAS).

Filling Liquid:

Mixture of water and propylene glycol to ensure adequate lubrication of the thrust bearing system together with the ability to lower the freezing point when stored in very cold places.

Restore Liquid Valve:

It allows water in to restore internal level.

Thrust Bearing System:

Kingsbury-type with stainless steel thrust bearing runners oscillating on a self-aligning system. A special runner lapping process makes this system extremely reliable and efficient.

100% Tested:

All motors are tested at the end of the line.



Single phase submersible motors 50hz 230v water cooled

Type	P ₂ [Hp]	P ₂ [kW]	Voltage [V]	Ph	I _n [A]	I _{avv} [A]	rpm	φ cos	η [%]	Capacitor [μF]	Thrust load [N]	Length A [mm]	Weight [kg]	Cable section [mm ²]	Cable Length [m]
HYO4-037S230	0,5	0,37	230	1	3,5	12,5	2860	0,87	52	20	2000	237	6,8	4 x 1,5	1,7
HYO4-055S230	0,75	0,55	230	1	4,8	17,2	2855	0,88	57	25	2000	257	7,9	4 x 1,5	1,7
HYO4-075S230	1	0,75	230	1	5,7	19,7	2840	0,9	62	35	2000	272	9,1	4 x 1,5	1,7
HYO4-110S230	1,5	1,1	230	1	8,2	27,2	2845	0,91	64	40	2000	297	11,2	4 x 1,5	1,7
HYO4-150S230	2	1,5	230	1	10,5	36,4	2840	0,93	66	50	3000	332	13,4	4 x 1,5	1,7
HYO4-220S230	3	2,2	230	1	15,2	48,9	2840	0,93	67	70	3000	387	14,2	4 x 1,5	1,7
HYO4-370S230	5	3,7	230	1	25	98,8	2845	0,95	73	00	6500	634	27,8	4 x 2	2,7

Single phase submersible motors 50hz 230v water cooled

Type	P ₂ [Hp]	P ₂ [kW]	Voltage [V]	Ph	I _n [A]	I _{avv} [A]	rpm	φ cos	η [%]	Capacitor [μF]	Thrust load [N]	Length A [mm]	Weight [kg]	Cable section [mm ²]	Cable Length [m]
HYA4-037T230	0,5	0,37	230	3	2,3	9,3	2855	0,57	71	-	2000	212	6,45	4 x 1,5	1,7
HYA4-055T230	0,75	0,55	230	3	2,8	14,0	2855	0,65	76	-	2000	237	7,2	4 x 1,5	1,7
HYA4-075T230	1	0,75	230	3	3,4	16,1	2850	0,72	77	-	2000	257	8,45	4 x 1,5	1,7
HYA4-110T230	1,5	1,1	230	3	5	26,0	2820	0,77	72	-	2000	272	9,35	4 x 1,5	1,7
HYA4-150T230	2	1,5	230	3	6,6	28,6	2835	0,80	71	-	3000	297	10,2	4 x 1,5	1,7
HYA4-220T230	3	2,2	230	3	9,8	41,1	2835	0,80	70	-	3000	332	11,65	4 x 1,5	1,7
HYA4-300T230	4	3	230	3	13	78,5	2855	0,79	73	-	3000	387	14,9	4 x 1,5	1,7
HYA4-400T230	5,5	4	230	3	17,2	89,4	2845	0,76	77	-	6500	574	20,05	4 x 2	2,7
HYA4-550T230	7,5	5,5	230	3	24,5	113,4	2850	0,76	74	-	6500	634	24,65	4 x 2	2,7

Single phase submersible motors 50hz 400v water cooled

Type	P ₂ [Hp]	P ₂ [kW]	Voltage [V]	Ph	I _n [A]	I _{avv} [A]	rpm	φ cos	η [%]	Capacitor [μF]	Thrust load [N]	Length A [mm]	Weight [kg]	Cable section [mm ²]	Cable Length [m]
HYA4-037T400	0,5	0,37	400	3	1,4	6,0	2850	0,54	70	-	2000	212	5,8	4 x 1,5	1,7
HYA4-055T400	0,75	0,55	400	3	1,7	8,3	2855	0,62	75	-	2000	237	6,8	4 x 1,5	1,7
HYA4-075T400	1	0,75	400	3	2,1	9,8	2825	0,76	68	-	2000	257	7,9	4 x 1,5	1,7
HYA4-110T400	1,5	1,1	400	3	3,2	16,1	2825	0,68	73	-	2000	272	9,1	4 x 1,5	1,7
HYA4-150T400	2	1,5	400	3	4,1	18,7	2840	0,75	71	-	3000	297	11,2	4 x 1,5	1,7
HYA4-220T400	3	2,2	400	3	5,9	28,1	2830	0,78	69	-	3000	332	13,4	4 x 1,5	1,7
HYA4-300T400	4	3	400	3	7,9	48,4	2850	0,76	72	-	3000	387	18,9	4 x 1,5	1,7
HYA4-400T400	5,5	4	400	3	10,1	51,5	2850	0,74	77	-	6500	574	23,4	4 x 2	2,7
HYA4-550T400	7,5	5,5	400	3	13,9	66,6	2850	0,77	74	-	6500	634	27,8	4 x 2	2,7
HYA4-750T400	10	7,5	400	3	16,9	91,5	2845	0,76	74	-	6500	734	31,4	4 x 2	2,7

Technical Specifications

Motor/Pump Flange	4" Nema Standard
Degree of protection	IP 68
Insulation Class	F
Voltage tolerance	- 10% / + 10%
Pumped liquid temperature	0°C - 35°C 32°F - 95°F
Min. Cooling Flow	0,1 m/s 0,328 ft/s
Max. Starts / Hour	30
Mounting	Vertical And/Or Horizontal
Max. Immersion Depth	300M
Thrust Load	From 0,5 to 3 Hp From 3 to 4 Hp From 5,5 to 10 Hp

Single Phase Version: Psc Type
(Permanent Split Capacitor)

Rewindable Motor Version

Cables, Voltage, Thrust Loads [...]
Special Versions Available.



HY06

6" Rewindable oil Filled submersible Motors

6" Rewindable Oil Filled Submersible Motors

Motors designed to work in 6" or wider wells. The use of very high quality Made in Italy materials and our strict tests together with consolidated know how ensure high mechanical resistance and high performing electric features.

All parts in contact with water are in AISI 304 stainless steel. The power cable with removable connector ensures perfect water-tightness. Designed to be easily repairable.

Product features

External Sleeve And Bottom:

Made in AISI 304 stainless steel. More specifically, the sleeve is in 304L (Low Carbon) to avoid possible corrosions on the welding.

Upper Support:

Cast iron with cataphoresis treatment. Sleeve clamping is ensured for the whole series by 8 inserts.

Mechanical Seal:

Graphite/ceramic in the standard version; SIC-SIC version available upon request.

Ball Bearings:

Duly oversized to ensure a long lasting motor.

Stator:

Specifically developed to achieve maximum electrical yield. Airtight sealed and immersed in selected mineral white and highly refined oil, suitable to be used in drinking water (F.D.A., Food and Drug Administration, approved).

Removable Power Cable-Connector:

It ensures perfect sealing in the most critical conditions and it aids maintenance operations. More specifically, the connector prevents oil from rising in the conductors up to the joint, thus enabling immersion at greater depths. The power cable complies with all major standards on the use in drinking water (KTW, ACS, WRAS).

Shaft:

Carbon-steel alloys in the rotor area, to foster electrical features. DUPLEX stainless steel projection. This steel combines excellent resistance to corrosion and high mechanical resistance, which is necessary where static torque becomes really important.

100% Tested:

All motors are tested at the end of the line. An extremely effective seal check is also carried out on all motors.



Three phase submersible motors 50Hz 400v oil filled

Type	Voltage [V]	P ₂ [Hp]	P ₂ [kW]	Ph	I _n [A]	I _{avv} [A]	rpm	cos	[%]	Thrust load [N]	Length A [mm]	Weight [kg]	Cable section [mm ²]	Cable Length [m]
HYO6-400T400 DOL HYO6-400T400 DS	400 400/690	5,5	4	3	9,1	47	2840	0,86	74	10000	595	34	4 x 4	3
HYO6-550T400 DOL HYO6-550T400 DS	400 400/690	7,5	5,5	3	12,8	66	2840	0,84	74	10000	625	41	4 x 4	3
HYO6-750T400 DOL HYO6-750T400 DS	400 400/690	10	7,5	3	16,8	81	2850	0,83	78	10000	660	46	4 x 4	3
HYO6-920T400 DOL HYO6-920T400 DS	400 400/690	12,5	9,2	3	21,2	98	2880	0,77	81	10000	700	48	4 x 4	3
HYO6-1100T400 DOL HYO6-1100T400 DS	400 400/690	15	11	3	22,9	123	2850	0,82	85	10000	765	52	4 x 4	3
HYO6-1300T400 DOL HYO6-1300T400 DS	400 400/690	17,5	13	3	27,6	141	2860	0,80	84	10000	820	57	4 x 4	3
HYO6-1500T400 DOL HYO6-1500T400 DS	400 400/690	20	15	3	30,7	158	2840	0,86	82	10000	820	58	4 x 4	3
HYO6-1850T400 DOL HYO6-1850T400 DS	400 400/690	25	18,5	3	38,0	231	2850	0,84	84	20000	883	64	4 x 8	4
HYO6-2200T400 DOL HYO6-2200T400 DS	400 400/690	30	22	3	45,5	258	2850	0,83	84	20000	953	71	4 x 8	4
HYO6-2600T400 DOL HYO6-2600T400 DS	400 400/690	35	26	3	52,0	296	2850	0,85	85	20000	1018	79	4 x 8	4
HYO6-3000T400 DOL HYO6-3000T400 DS	400 400/690	40	30	3	61,5	348	2860	0,83	85	20000	1098	87	4 x 8	4
HYO6-3700T400 DOL HYO6-3700T400 DS	400 400/690	50	37	3	76,0	396	2840	0,84	84	20000	1233	99	4 x 8	4



D. O. L. VERSION



Δ-Δ VERSION

Technical Specifications

Motor/Pump Flange	6" Nema Standard
Degree of protection	IP 68
Insulation Class	F
Voltage tolerance	- 10% / + 10%
Pumped liquid temperature	0°C - 35°C 32°F - 95°F
Min. Cooling Flow	0,1 m/s 0,328 ft/s
Max. Starts / Hour	30
Mounting	Vertical And/Or Horizontal
Max. Immersion Depth	300M
Thrust Load	
From 5,5 HP to 20 HP	10.000N
From 25 HP to 50 HP	20.000N

Rewindable motor

Cables, Voltage, Thrust Loads [...]
Special Versions Available.

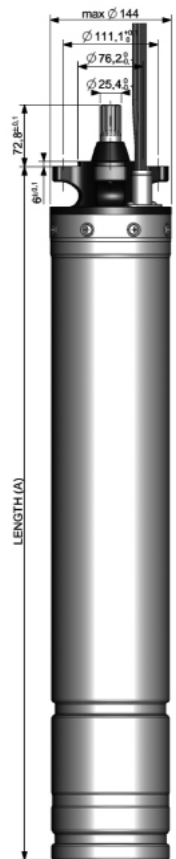

HYA6

6" Rewindable water Cooled submersible Motors

6" Rewindable Water Cooled Submersible Motors

Motors designed to work in 6" or wider wells. The use of very high quality Made in Italy materials and our strict tests together with consolidated know how ensure high mechanical resistance and high performing electric features. Designed to be easily repairable.

Product features

Stator:

Specifically developed to achieve maximum electrical yield. Covered by an AISI 304 stainless steel sleeve. Windings are asynchronous-type and are made of cooper wire with PVC insulation, or copper wire with PE2+PA insulation, which is "inverter resistant" and suggested for high temperatures and voltage surges.

Power cable:

It ensures perfect sealing in the most critical conditions. Cable is EPR-type and complies with all major standards on the use in drinking water (KTW, ACS, WRAS).

Filling Liquid:

Mixture of water and propylene glycol to ensure adequate lubrication of the thrust bearing system together with the ability to lower the freezing point when stored in very cold places.

Upper And Lower Support:

GS400 spheroidal cast iron with cataphoresis treatment, which gives great resistance to water impacts and corrosion.

Mechanical Seal:

SIC-SIC, silicon-silicon carbide.

Shaft:

Completely in AISI 420 stainless steel, without welding. It is ground along the entire axis thus giving the rotor such a concentricity to ensure perfect linearity. A shaft free from vibration is obtained thanks to balancing. Led by wear-resistant graphite bushing bearings.

Thrust Bearing System:

Bidirectional Michell-type, with pads in treated steel and supported by a disk in resin compound fibres and self lubricating additives, totally ecological.

100% Tested:

All motors are tested at the end of the line.



Electrical Data - 50Hz

Type	P [Hp]	P [kW]	I _n [A]		Starting		cos	[%]	rpm	Thrust load [N]	Length [mm]	Weight [kg]	Cable section [mm ²]				Cable Length [m]	T _{max}				
					Direct	Δ / Y							Direct		Δ / Y			H ₂ O	PE2 + I PA			
			230V	400V	I _a / I _n	I _a / I _n							230V	400V	230/400V	400/690V		PVC	PE2 + I PA			
HYA6-400	5,5	4	16	9,5	5,2	1,3	0,83	79,5	2880	18000	640	41	4 x 3	4 x 3	4 x 6	4 x 6	3,5	30°C 86°F	55°C 131°F			
HYA6-550	7,5	5,5	21,5	12,5	4,9	1,6	0,87	78	2850		670	44										
HYA6-750	10	7,5	29,5	17	5,35	1,7	0,86	78,5	2850		700	46										
HYA6-920	12,5	9,2	36	21,5	5,05	1,7	0,86	78	2830		740	50										
HYA6-1100	15	11	42,5	24,5	5	1,6	0,87	79	2840		770	54										
HYA6-1300	17,5	13	51	29	5	1,6	0,86	80	2840		840	61										
HYA6-1500	20	15	60	34	5,05	1,6	0,86	81	2830	840	62	6 x 3	4 x 3	4 x 6	3,5	30°C 86°F	55°C 131°F					
HYA6-1850	25	18,5	69,5	40	4,85	1,6	0,86	82	2845	900	68											
HYA6-2200	30	22	83	48	4,6	1,5	0,86	83	2845	25000	970	75	10 x 3	6 x 3	6 x 6	3,5	25°C 77°F	45°C 113°F				
HYA6-2600	35	26	95	55	4,9	1,6	0,87	82,5	2830		1040	82										
HYA6-3000	40	30	113,5	65,5	5,15	1,7	0,85	83	2840		1100	89										
HYA6-3700	50	37	138,5	80	4,75	1,5	0,85	83	2840		1240	103							-	10 x 3	10 x 6	6 x 6
HYA6-4500	60	45	167	96,5	5,05	1,6	0,85	83	2840		1370	116							-	10 x 3	10 x 6	6 x 6
																						10 x 6

Technical Specifications

Motor/Pump Flange	6" Nema Standard
Degree of protection	IP 68
Insulation Class	PVC: Y PE2 + PA: B
Voltage tolerance	- 10% / + 6%
Pumped liquid temperature	Refer to electrical data sheet
Min. Cooling Flow	0,15 m/s 0,492 ft/s
Max. Starts / Hour	10
Mounting	Vertical And/Or Horizontal
Max. Immersion Depth	350M
Thrust Load	
From 5,5 to 20 HP	18.000N
From 25 to 60 HP	25.000N

Rewindable motor

Special cables/Voltage/Thrust Loads,
Y/Δ Starting, Pt100 Temperature sensor [...]
Available Upon Request.

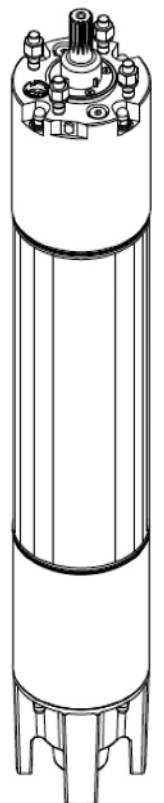

Notes

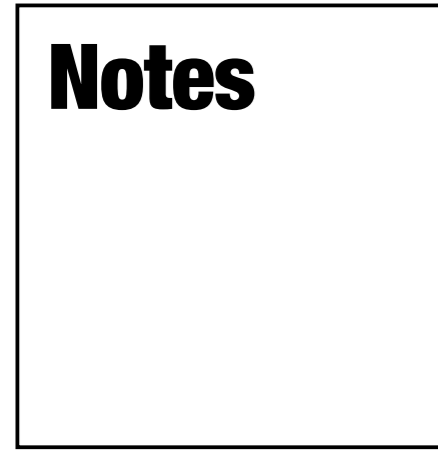

A series of horizontal dotted lines for writing notes, extending across the width of the page.

A series of horizontal dotted lines for writing notes, extending across the width of the page.

hydroo®

Be pumping partners

æcht vertriebsgesellschaft mbH

Postfach 1234
63402 Hanau, Deutschland
Tel. +49 (0)69 348 790 780
Fax +49 (0)69 348 790 787
E-mail hydroo@aecht.net

www.hydroo.com/de

HYDROO Pump Industries SL.

Carrer La Banyeta Nova, 11
Polígon Industrial La Banyeta
17843 Palol de Revardit Catalonia. Spain
Tel. +34 972 394 654
E-mail: info@hydroo.com

201841-CTL-SX&SN-EN
subject to amendments

