

Besides extrusion, another core competence of IANUS is the optimisation of pumps and pump-systems like spiral pumps, screw pumps, gear pumps, oscillating displacement pumps, gerotor pumps or diaphragm pumps. So, we can not only optimise the pumps but also the pump-system in general to achieve the best use of the pumps in combination with the system.

Important factors are the efficient optimisation of the system, the avoidance of costs for potential misconstructions and the maximum increase of quality for the final products.

That brings a lot of benefits to the customer. For example, the customer can avoid time- and cost-consuming trials because of the simulations from IANUS and our experience.

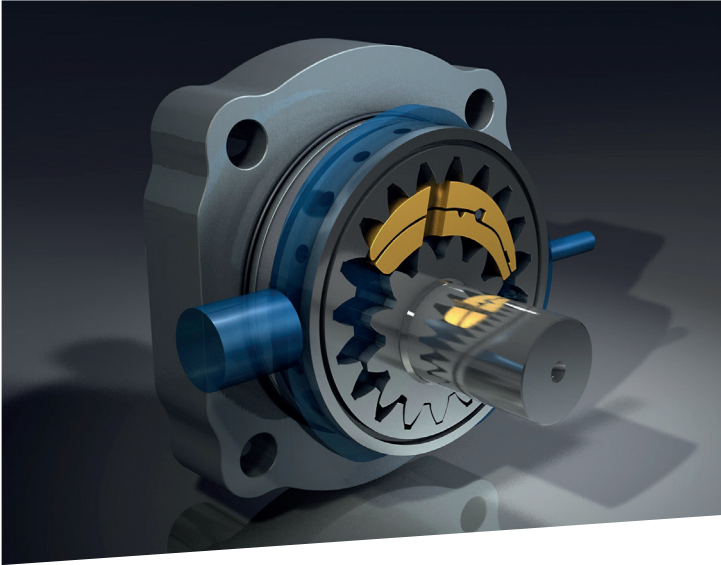

- high shear rates
- cavitations
- pulsations
- turbulences in the pumps
- inefficient pipe conditions after the pump

can be minimised significantly by simulations and the wear behaviour of the pump sharply optimised.

Furthermore, the determining of the optimal operating point of the system is a big problem for system operators often and can be very easy determined by simulations of the performance curve beforehand.

Pump developers will have a lot of advantages due to simulations:

- no investments in powerful and cost intensive computer technology
- enormous time saving
- no expensive costs for operating personnel and the familiarisation of it
- short time of amortisation = quick ROI

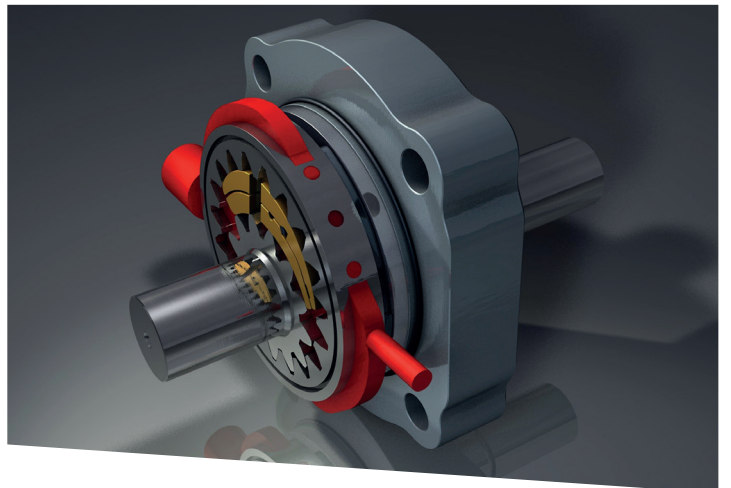

Based on the FeatFlow-concept, which is awarded several times, our exclusive 3D CFD Code Pump3DPro is an economic high-tech analysis tool for any simulation of flow processes.

The many years of experience in flow simulations makes IANUS to your perfect partner for an optimisation of your pumps or your pump-system.

IANUS – observe, comprehend, improve.