

BANDSCHLEIFAGGREGAT - CLASSIC LINE

COLLEVO

TECHNISCHE DATEN

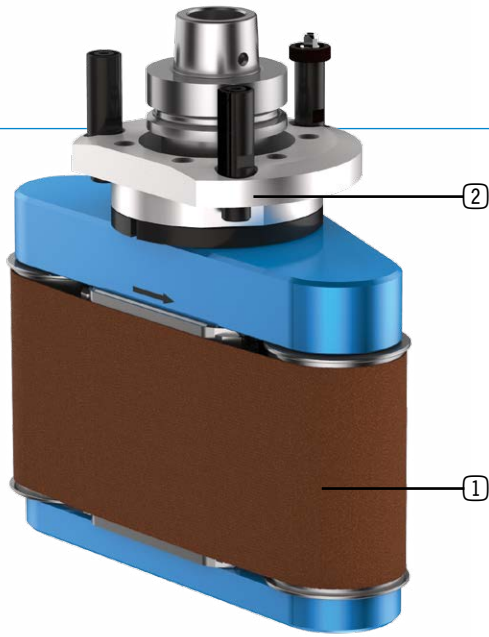

- ▶ **Schmierung** Fett
- ▶ **max. Abtriebsdrehzahl n_2** 2.700 min⁻¹
- ▶ **Übersetzung ($n_1 : n_2$)** 1:0,9
- ▶ **max. Abtriebsdrehmoment M_2** 10 Nm
- ▶ **Gewicht** ca. 9 kg

Standardausführung

① Schleifband



Breite 100 mm,
Länge 560 mm

② Maschinenanbindung



HSK - F63



Video



▶ **Aggregat - live in der Anwendung**

QR Code scannen oder alternativ:

[www.youtube.com/
BENZWerkzeugsysteme](http://www.youtube.com/BENZWerkzeugsysteme)

Spezifikationen

Bearbeitung



Anzahl
Werkzeugaufnahmen



Achswinkel



C - Winkel



Schmierung



COLLEVO

▶ WEITERE OPTIONEN: MODULARER AUFBAU

①



▶ SCHLEIFBAND



Breite 100 mm,
Länge 560 mm

②



▶ MASCHINENANBINDUNG



HSK - F63
BIESSE



SK 30
BIESSE



HSK - F63
Busellato



HSK - F63
Felder



HSK - F63
HOMAG / WEEKE / WEINMANN



HSK - F63
IMA



HSK - F63
Masterwood



HSK - F63
SCM



HSK - F63
SCM



HSK - F63
Weinig



Weitere Informationen S. 40