

BELT SANDING UNIT - CLASSIC LINE

COLLEVO

► TECHNICAL DATA

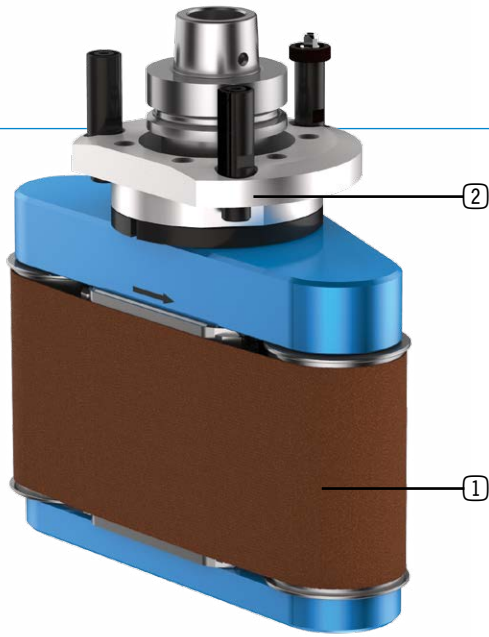

- **Lubrication** Grease
- **Max. drive speed n_2** 2,700 rpm
- **Transmission ratio ($n_1 : n_2$)** 1:0.9
- **Max. drive torque M_2** 10 Nm
- **Weight** about 9 kg

Standard design

① Sanding belt



Width 100 mm,
length 560 mm

② Machine connection



HSK - F63



Video



► Unit - live in the application

Scan QR code or go to:

[www.youtube.com/
BENZWerkzeugsysteme](http://www.youtube.com/BENZWerkzeugsysteme)

► Specifications

Machining



Number of
output spindles



Axis angle



C-angle



Lubrication



COLLEVO

▶ ADDITIONAL OPTIONS: MODULAR DESIGN

①



▶ SANDING BELT



Width 100 mm,
length 560 mm

②



▶ MACHINE CONNECTION



HSK - F63
BIESSE



SK 30
BIESSE



HSK - F63
Busellato



HSK - F63
Felder



HSK - F63
HOMAG / WEEKE / WEINMANN



HSK - F63
IMA



HSK - F63
Masterwood



HSK - F63
SCM



HSK - F63
SCM



HSK - F63
Weinig



For further information see p. 40