

FLOATING TRIMMING UNIT - CLASSIC LINE

FLOATING

▶ TECHNICAL DATA

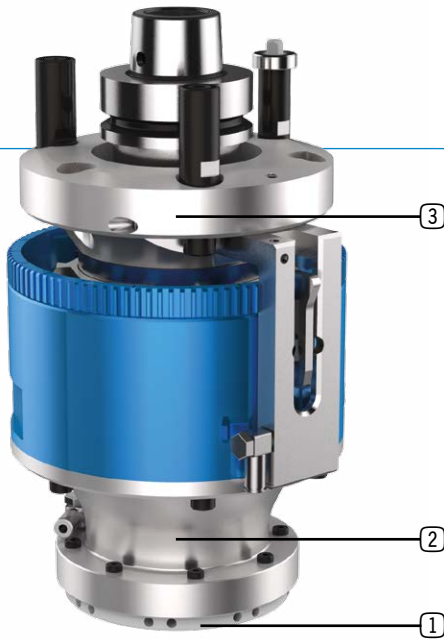

- ▶ **Lubrication** Grease
- ▶ **Max. drive speed n_2** 18,000 rpm
- ▶ **Transmission ratio ($n_1 : n_2$)** 1:1
- ▶ **Max. drive torque M_2** 10 Nm
- ▶ **Weight** about 6 kg

Standard design

1 Internal diameter of floating ring

70

2 Output spindle

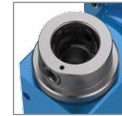

BENZ
Solidfix® S3

3 Machine connection



HSK - F63



Video



▶ Unit - live in the application

Scan QR code or go to:

[www.youtube.com/
BENZWerkzeugsysteme](http://www.youtube.com/BENZWerkzeugsysteme)

▶ Specifications

Machining



Number of output spindles

1

Axis angle



C-angle

-

Lubrication



FLOATING



► ADDITIONAL OPTIONS: MODULAR DESIGN

①



► INTERNAL DIAMETER OF FLOATING RING

70

94

105

122

i Additional internal diameters of floating ring on request

②



► OUTPUT SPINDLE



BENZ
Solidfix® S3

i For further information see p. 36

③



► MACHINE CONNECTION



HSK - F63
BIESSE



SK 30
BIESSE



HSK - F63
Busellato



HSK - F63
Felder



HSK - F63
HOMAG / WEEKE / WEINMANN



HSK - F63
IMA



HSK - F63
Masterwood



HSK - F63
SCM



HSK - F63
SCM



HSK - F63
Weinig

i For further information see p. 40