

High-Capacity Hammer Mill

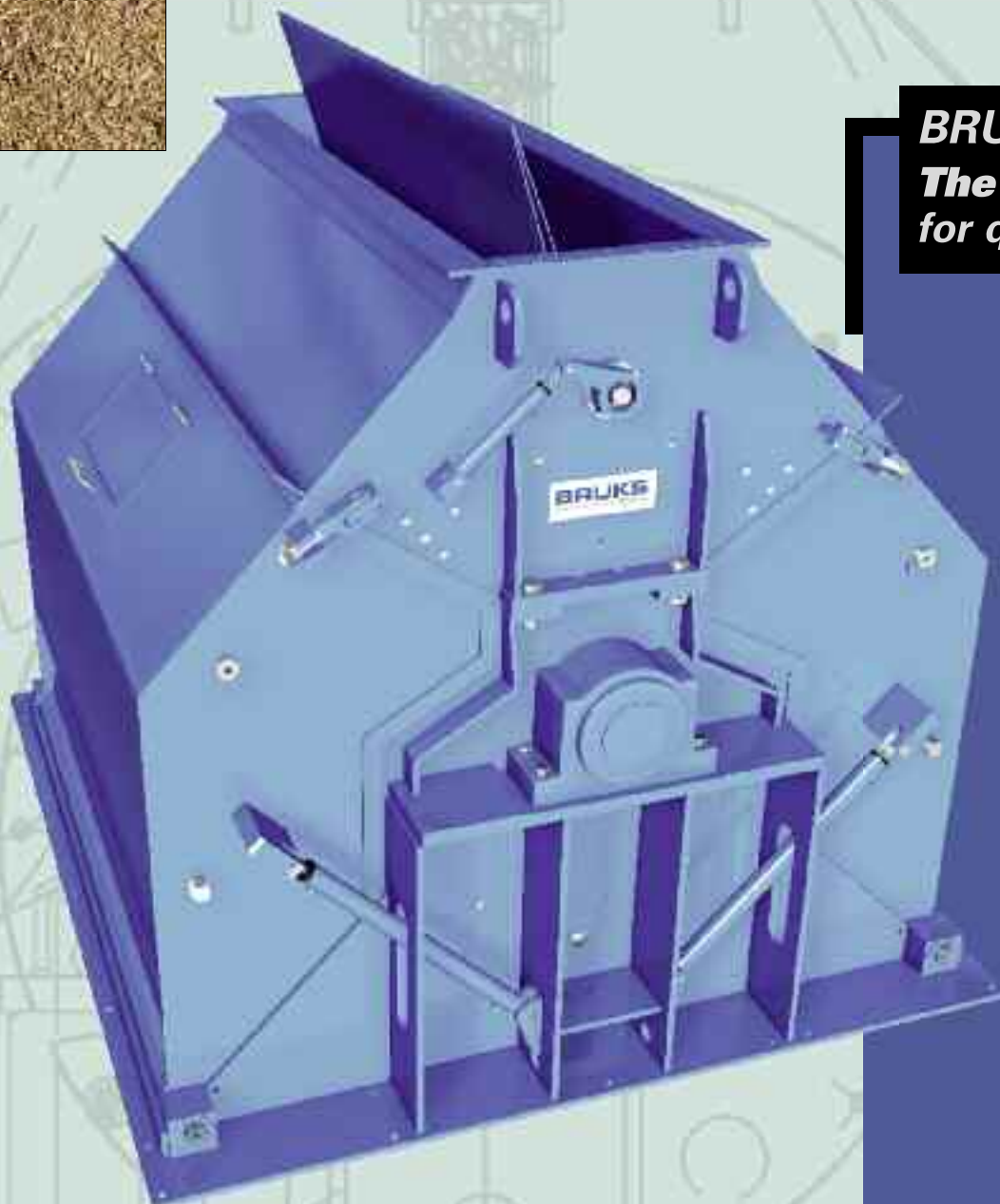

BRUKS -
The name
for quality

BRUKS®

BRUKS - one of the world's leading manufacturers of machines and equipment for the pulp, board and recycling industries as well as the handling of sawmill by-products.

High throughput capacity !



Heavy particle separation removes e.g. stones, non-ferrous metals, etc.

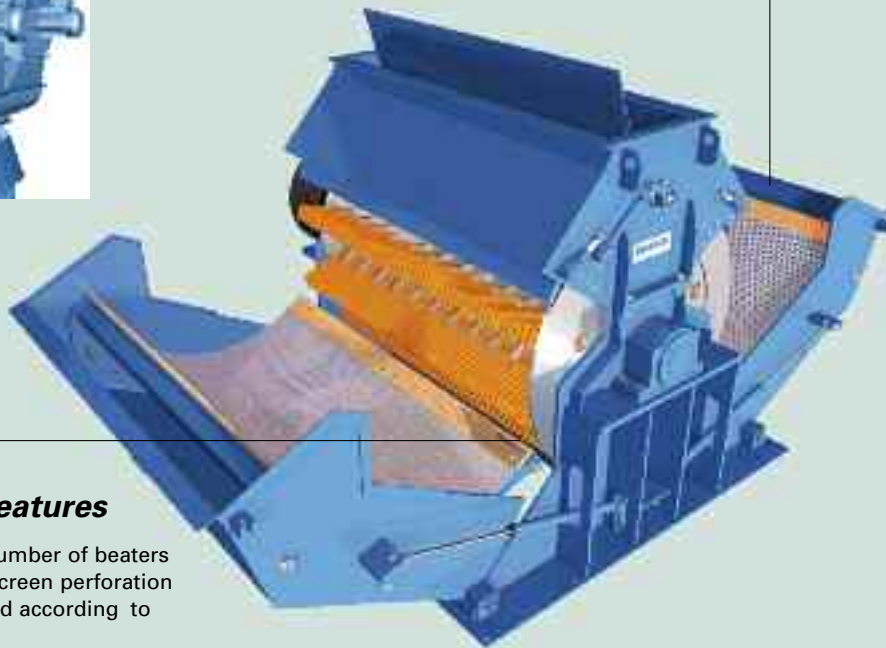

Quick access to all machine parts

Quick replacement of wear parts because of simple and secure clamping of screens and milling segments.

Both of the lateral housing parts incl. screens and milling segments can be hydraulically folded away. This ensures quick and easy access to all machine parts.

Machine features

The type and number of beaters as well as the screen perforation are dimensioned according to requirements.

The machine is designed for counter-clockwise and clockwise rotation. Thus turning of beaters, screens and milling segments is not necessary and maintenance is reduced.

Low tool costs because beaters are of highly wear-resistant material and suitable to be used from four sides.

Rotor

with bearings and V-belt pulley

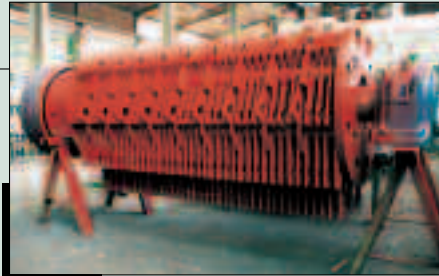

Application

Production of high-quality fibers for: Board industry, pellet production, briquetting, wood composites, boiler fuel.

Product advantage

High throughput

High-quality fibers from different input material

Appropriate for wet and dry milling

Sturdy design

Low tool costs



Technical Data High-Capacity Hammer Mill

Type BK-HH	Rotor Ø (mm)	Infeed opening (mm)	Main drive power (kW)	Capacity (to/h)*	Weight (kg)**
300 x 800	700	300 x 800	75 - 110	2 - 4	1.400
300 x 1200	700	300 x 1200	110 - 160	3 - 6	2.400
400 x 1500	1000	400 x 1500	160 - 250	5 - 10	6.300
500 x 1800	1300	500 x 1800	250 - 400	8 - 18	9.500
600 x 2000	1600	600 x 2000	400 - 630	15 - 25	14.000

* Depending on type and size of material, humidity and screen perforation
 ** Only Hammer Mill without drive, CLEANER, feeding system, etc.

BRUKS AB
 Phone: +46 (0) 278-642500
 info@bruks.com

BRUKS KLÖCKNER GmbH
 Phone: +49 (0) 26 61-280
 info.de@bruks.com

BRUKS Rockwood Inc.
 Phone: +01-770-849-0100
 info.us@bruks.com

www.bruks.com