



Quality - service and experience
since 1911

MORSØ

Notch Cutting Machines



To compare **MORSØ-NF** and **NFX** with a moulding machine the following points must be considered:

1. a cleaner and more constantly accurate cut will be produced with **MORSØ-NF/NFX**
2. the **MORSØ-NF/NFX** produces no dust and therefore requires no extraction.
3. the **MORSØ-NF/NFX** requires less than 15 minutes to change the cutting blades, to the set-up, and to the positioning of the stops.
4. as the blades wear, the 45° angle remains unchanged, ensuring consistently accurate joints.
5. The **MORSØ-NF/NFX** cuts plastic, all kinds of wood including MDF.

MORSØ-NF/NFX are delivered with safety guard, waste chute, 6 sliding longitudinal stops, fences on both the right and left side of the machine, 1 nose knives (size per request), 1 pair of side knives.

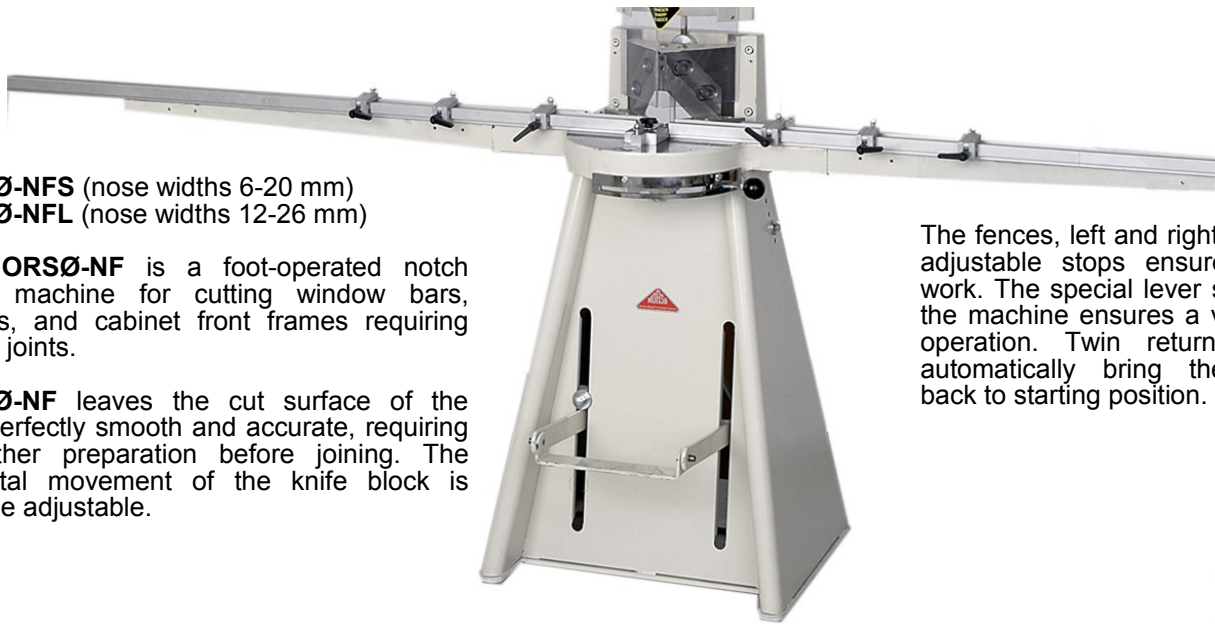

MORSØ-NFS (nose widths 6-20 mm)
MORSØ-NFL (nose widths 12-26 mm)

The **MORSØ-NF** is a foot-operated notch cutting machine for cutting window bars, mullions, and cabinet front frames requiring haunch joints.

MORSØ-NF leaves the cut surface of the wood perfectly smooth and accurate, requiring no further preparation before joining. The horizontal movement of the knife block is stepwise adjustable.

The fences, left and right, with the adjustable stops ensure correct work. The special lever system of the machine ensures a very easy operation. Twin return springs automatically bring the knives back to starting position.

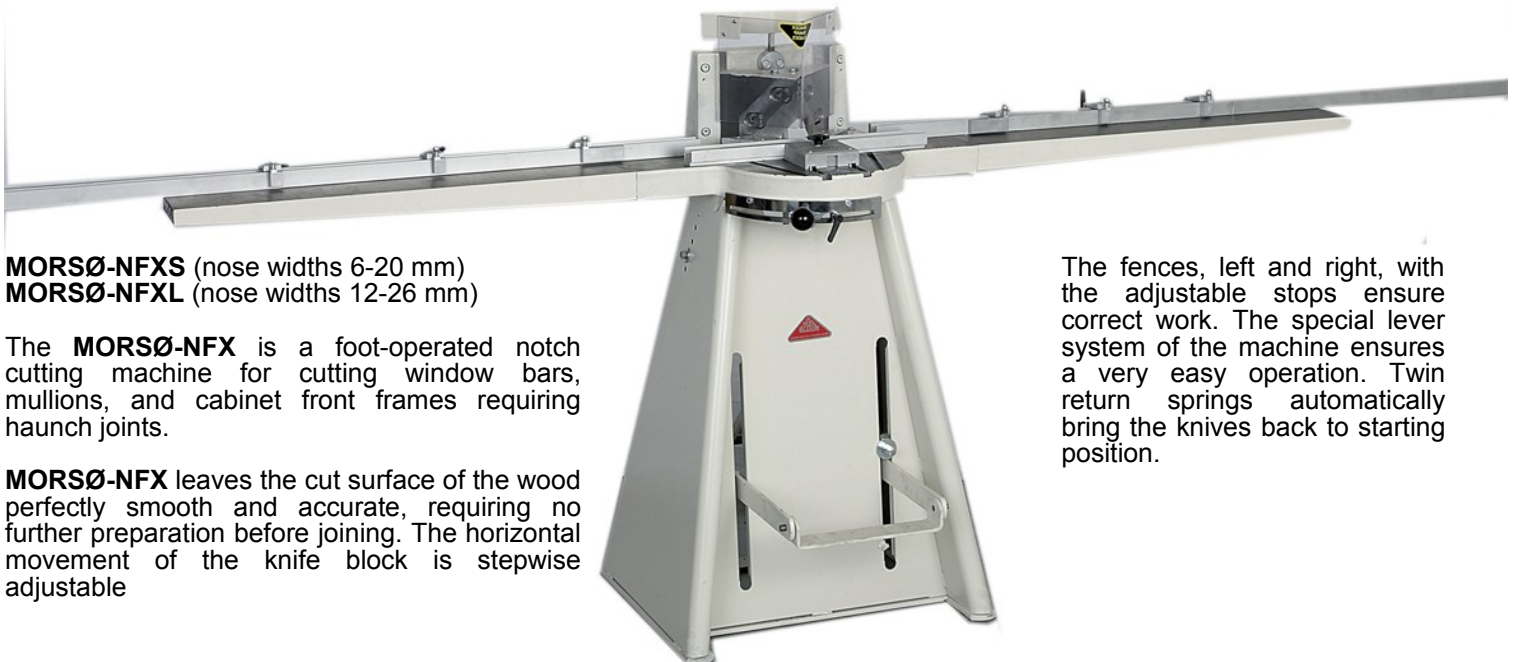

MORSØ-NFXS (nose widths 6-20 mm)
MORSØ-NFXL (nose widths 12-26 mm)

The **MORSØ-NFX** is a foot-operated notch cutting machine for cutting window bars, mullions, and cabinet front frames requiring haunch joints.

MORSØ-NFX leaves the cut surface of the wood perfectly smooth and accurate, requiring no further preparation before joining. The horizontal movement of the knife block is stepwise adjustable.

The fences, left and right, with the adjustable stops ensure correct work. The special lever system of the machine ensures a very easy operation. Twin return springs automatically bring the knives back to starting position.



Haraldsvej 21 - DK-8960 Randers - Denmark
Tel.: +45 8643 5155 - Fax: +45 8643 5100
e-mail: danlist@danlist.dk
www.danlist.dk - www.danlistvideos.com



Quality - service and experience
since 1911

MORSØ

Notch Cutting Machines



The advantage with the NEH and the NXLEH models is its ease of use. The hydraulic cutting action is activated by the operation of dual-hand control, ensuring total safety. The **MORSØ-NEH/NXLEH** are available with either single or three-phase motor. Voltage at request.

To compare **MORSØ-NEH/NXLEH** with a moulding machine the following points must be considered:

1. a cleaner and more constantly accurate cut will be produced with **MORSØ-NEH/NXLEH**
2. the **MORSØ-NEH/NXLEH** is almost silent by comparison.
3. the **MORSØ-NEH/NXLEH** produces no dust and therefore requires no extraction.
4. the **MORSØ-NEH/NXLEH** requires less than 15 minutes to change the cutting blades, to the set-up, and to the positioning of the stops.
5. as the blades wear, the 45° angle remains unchanged, ensuring consistently accurate joints.



MORSØ-NSEH (nose widths 6-20 mm)
MORSØ-NLEH (nose widths 12-26 mm)

MORSØ-NEH an electric/hydraulic guillotine for cutting window bars, mullions, and cabinet front frames requiring haunch joints.

MORSØ-NEH is a machine designed for medium-high volume production – the noise level is below 70 db. The **MORSØ-NEH** will cut plastic, all kinds of wood including MDF. The **MORSØ-NEH** operates in principle the same as MORSO-NF.

The **MORSØ-NEH** is supplied with the same standard equipment as the **MORSØ-NF** plus it has:

- Automatic cutting cycles for both large and small work pieces – which means that the machine always does the trim cut which is very important.
- Adjustable length of stroke (2 positions) – when using the lowest cutting position the cutting cycle of two cuts only takes between 1 and 1.5 seconds.

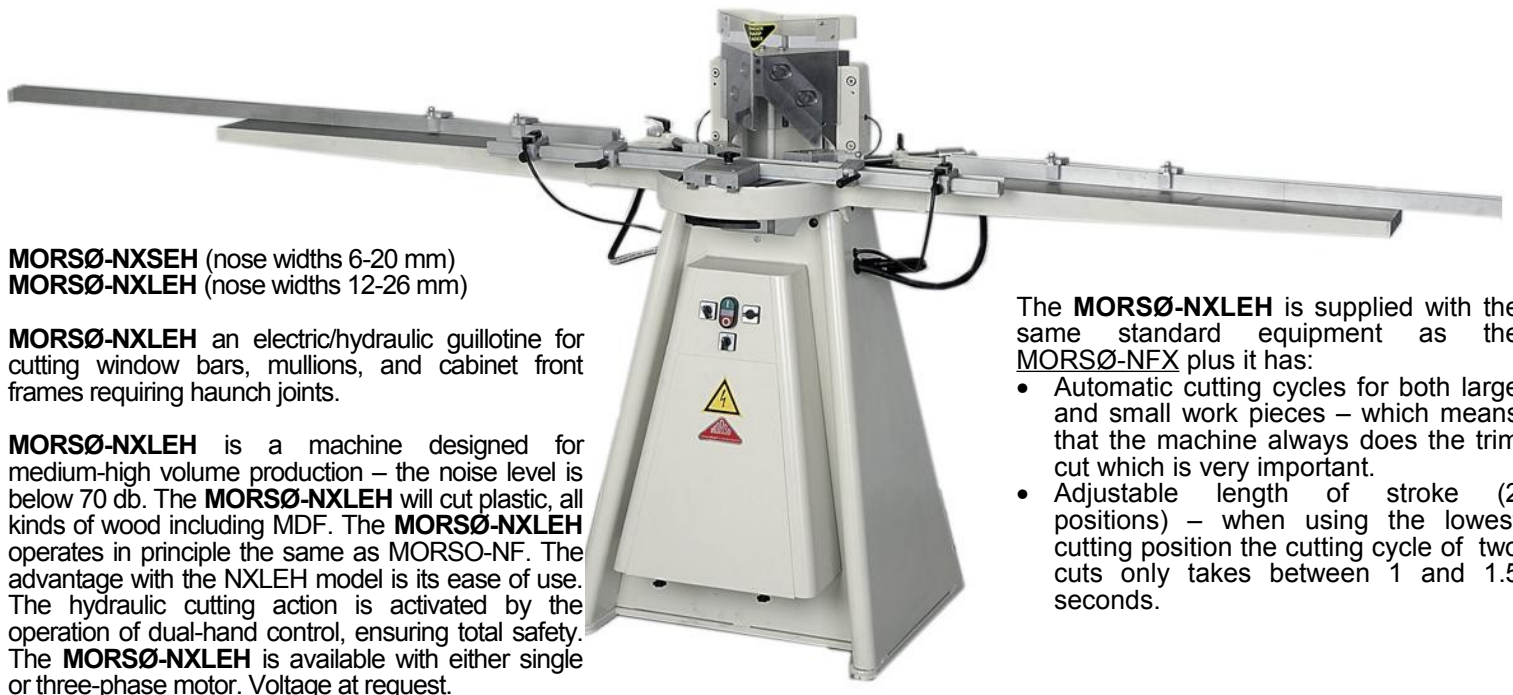

MORSØ-NXSEH (nose widths 6-20 mm)
MORSØ-NXLEH (nose widths 12-26 mm)

MORSØ-NXLEH an electric/hydraulic guillotine for cutting window bars, mullions, and cabinet front frames requiring haunch joints.

MORSØ-NXLEH is a machine designed for medium-high volume production – the noise level is below 70 db. The **MORSØ-NXLEH** will cut plastic, all kinds of wood including MDF. The **MORSØ-NXLEH** operates in principle the same as MORSO-NF. The advantage with the NXLEH model is its ease of use. The hydraulic cutting action is activated by the operation of dual-hand control, ensuring total safety. The **MORSØ-NXLEH** is available with either single or three-phase motor. Voltage at request.

The **MORSØ-NXLEH** is supplied with the same standard equipment as the **MORSØ-NFX** plus it has:

- Automatic cutting cycles for both large and small work pieces – which means that the machine always does the trim cut which is very important.
- Adjustable length of stroke (2 positions) – when using the lowest cutting position the cutting cycle of two cuts only takes between 1 and 1.5 seconds.



Quality - service and experience
since 1911

MORSØ

Routing Machines



Routing Machine KS-MINI

The perfect machine for producing the half-lap joint as found in Georgian window bars. It is used for both "plant-on cassettes" and rebated bars.

MORSØ-KS MINI routing machine is semi-automatic (pneumatic/electric)

MORSØ-KS MINI routing machine is constructed for routing of grooves from 6 - 26 mm wide and up to 20 mm deep. Quick adjustment from one size of nose width to another.

It is ideally used in conjunction with the MORSØ-N range of notch cutting machines.



Routing Machine KSD

The perfect machine for producing the half-lap joint as found in Georgian window bars. It is used for both "plant-on cassettes" and rebated bars.

MORSØ-KSD routing machine is with manual feed and clamping. The motor is single phase 220 V.

MORSØ-KSD routing machine is constructed for routing of grooves from 6 - 20 mm wide and up to 20 mm deep. Quick adjustment from one size of nose width to another.

It is ideally used in conjunction with the MORSØ-N range of notch cutting machines



Routing Machine KS

The perfect machine for producing the half-lap joint as found in Georgian window bars. It is used for both "plant-on cassettes" and rebated bars.

MORSØ-KS routing machine is semi-automatic (pneumatic/electric)

MORSØ-KS routing machine is constructed for routing of grooves from 6 - 26 mm wide. Quick adjustment from one size of nose width to another.

It is ideally used in conjunction with the MORSØ-N range of notch cutting machines.

