

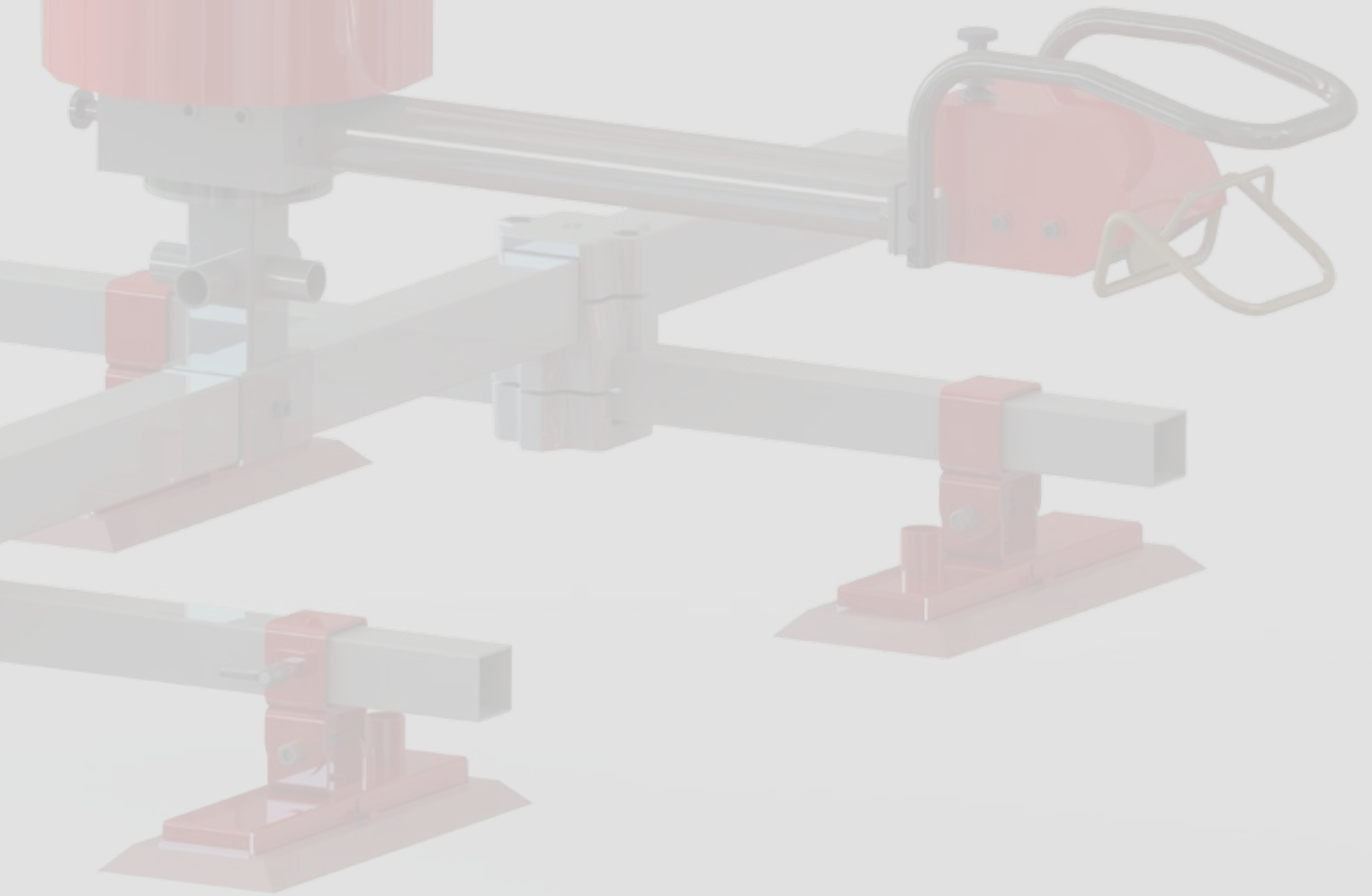

# euroTECH

VACUUM TECHNOLOGIES



## eT-Lift and accessories

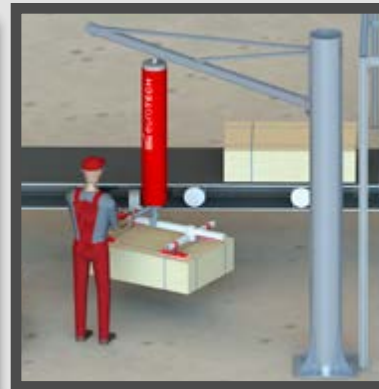

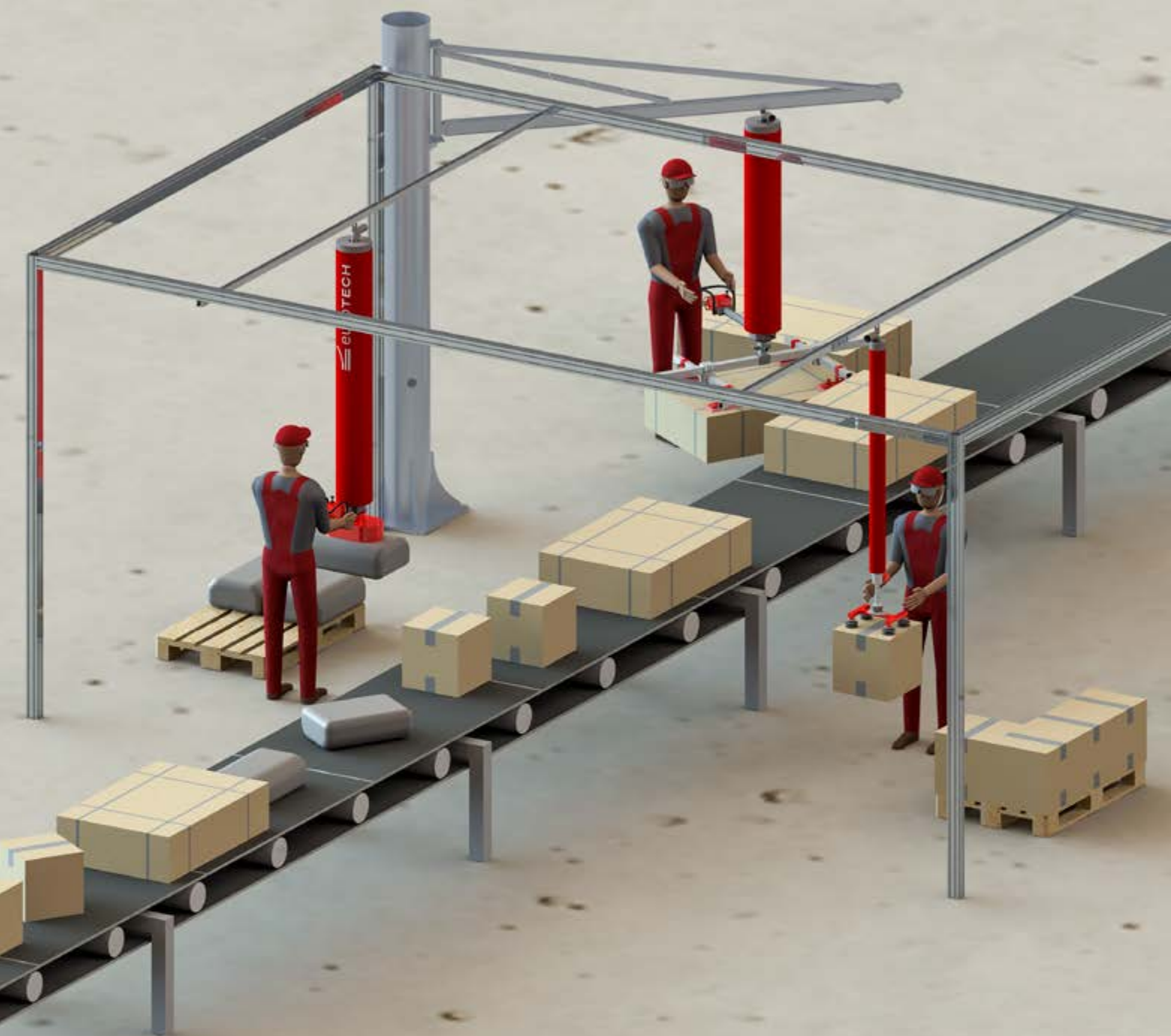

# For flexible use:

## The eT-Lift tube lifter series

In times of strong transport flows and ever quicker production processes, handling tools that meet these requirements are necessary. Tube lifters help master these challenges. They work efficiently and, owing to their ergonomic operation, they help avoid absentee times due to illness.

They lift cardboard boxes, bags, barrels, plates and many other loads handled in production, logistics, shipping or order picking. They can be used on pillar

jib cranes or lightweight suspended crane systems. The modular structure and manifold combination options provide for an all-round tailor-made solution for every customer.

We provide 3 different options:

- the **eT-Lift-mini**
- the **eT-Lift-eco** and
- the **eT-Lift-flexi** (= **eT-Lift-eco** with longer operating handle).



**eT-Lift-mini**  
for small, manageable loads

Page 3



**eT-Lift-eco**  
for plates, boxes, bags, barrels  
and other loads up to 250 kg

Page 5

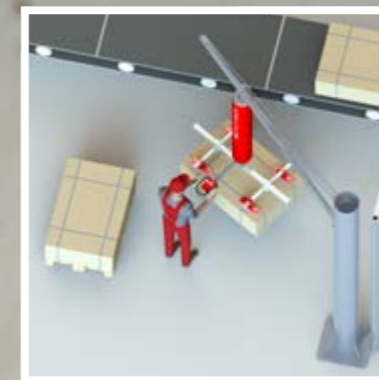

**Crane technology**  
pillar or wall-mounted jib cranes and  
lightweight suspended crane systems

Page 11

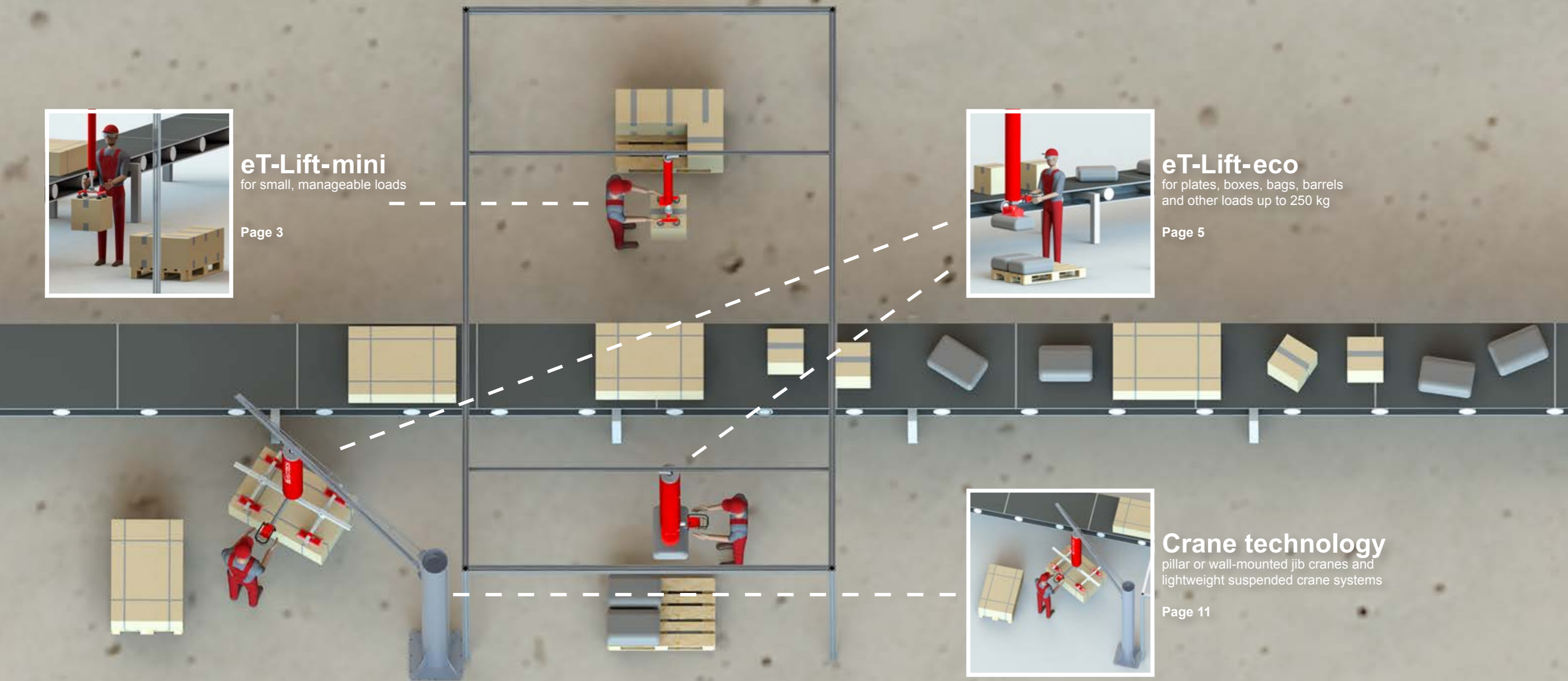



## Advantages

- **1. Ergonomics** —
  - ▶ Measures that provide for physical stress relief and thus alleviate workload are ergonomically very sensible, even necessary investments in the medical field.
- **2. Planning** —
  - ▶ Customer-oriented consulting
  - ▶ Competent planning and project development as appropriate to needs
  - ▶ Everything from one source, from system planning to commissioning
  - ▶ Standard solutions for many application cases
  - ▶ Retrofitting in existing operating processes
  - ▶ Customised, user-specific solutions
- **3. Energy savings** —
  - ▶ Low vacuum losses because of the high quality of workmanship
  - ▶ Energy-efficient vacuum generator
- **4. Safety** —
  - ▶ Ergonomic one-hand control
  - ▶ Load handling equipment with safety factor of 2.5
- **5. Durability** —
  - ▶ Precision in development and manufacturing
  - ▶ Resilient materials
  - ▶ Surface finishing
  - ▶ High quality of workmanship
  - ▶ Tried and proven technology
- **6. Low maintenance** —
  - ▶ Modular, clear device assembly
  - ▶ Good accessibility of components for cleaning and maintenance
  - ▶ Low number of components and few wear parts
  - ▶ Support closely oriented on customer needs
  - ▶ Quick spare parts service



General information

Small, compact tube lifter with one-hand operation in different models with a carrying capacity of up to max. 60 kg. A pump or ejector generates the vacuum. Different tooling and attachment parts make this tube lifter a tool adept for universal use.

The pick-and-place device for frequently recurring work processes – compact and fast.

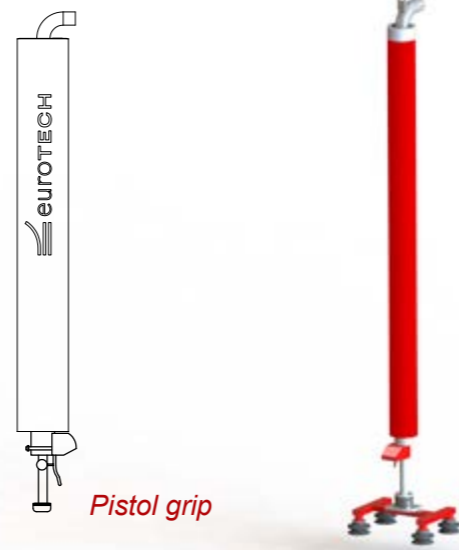

Technical data / Order data

Type	carrying capacity max. (kg)	Tare weight (kg)	Lifting tube (mm Ø)	Art.-No.
eT-Lift-mini 20	20	6	80	M011500
eT-Lift-mini 30	30	8	100	M011501
eT-Lift-mini 45	45	10	120	M011502
eT-Lift-mini 65	65	12	140	M011503

Technical changes reserved.

Tooling and accessories

Type	Description	Art.-No.
eT-Lift, lifting beam, for mini, 1x 40×40×4 – 500, 2x 40×40×4 – 300, 4x 110 CO	1x main beam, aluminum, 40×40×4– 500 mm 2x cross beam, aluminum, 40×40×4– 300 mm 4x bellow suction cups 110 CO (1.5 folds, NBR grey) 1x quick-change mechanism  Suitable for lifting loads such as chipboards, cardboard boxes, etc. with maximum dimensions of up to 600×400 mm.  The lifting beam is completely welded. The tool has a maximum carrying capacity of 65 kg.	B009861
eT-Lift, round suction cup for mini, 1x 150 CO	1x bellow suction cup 150 CO (1.5 folds, NBR grey) 1x quick-change mechanism  Suitable for lifting loads such as chipboards, cardboard boxes, etc. with maximum dimensions of up to 500×500 mm.  The tool has a maximum carrying capacity of 30 kg.	B009862
eT-Lift, vacuum pump type VT 4.50	Vacuum generator for tube lifters of type eT-Lift-mini, voltage 3×400 V, 50/60 Hz 1,25 kW	M011491
eT-Lift, ejector	Pressurised air vacuum generator for tube lifter of type eT-Lift-mini, suction capacity 720 NI/min, air consumption 210 NI/min	B010117

Technical changes reserved. | Further tooling available.

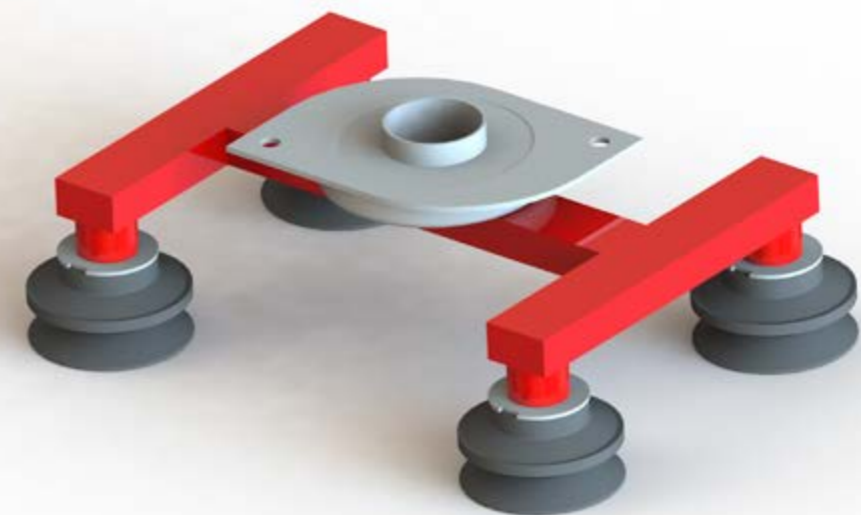

General information

The eT-Lift-eco is a compact and safely operating tube lifter with diverse possibilities for use. The graded carrying capacities range from min. 30 kg to max. 250 kg. The vacuum is generated by a blower or a vacuum pump depending on the area of use. There is a wide range of standard load handling equipment to choose from, while also custom-oriented solutions can be delivered.



Technical data / Order data

Type	Carrying capacity max. (kg)	Tare weight (kg)	Lifting tube (mm Ø)	Art.-No.
eT-Lift-eco 30	30	11	100	M011501
eT-Lift-eco 45	45	12	120	M011497
eT-Lift-eco 60	60	13	140	M011295
eT-Lift-eco 80	80	13	160	M011296
eT-Lift-eco 100	100	14	180	M011297
eT-Lift-eco 125	125	15	200	M011298
eT-Lift-eco 185	185	17	230	M011499
eT-Lift-eco 220	220	24	250	M011498
eT-Lift-eco 250	250	26	2x200	M011299

Technical changes reserved. | Further versions available.

Type	Dimensions of control handle (mm)		Standard tube length 2,5m		Special tube length 3m		Special tube length 4m	
	A	B	Stroke (mm)	Installation height (mm)	Stroke (mm)	Installation height (mm)	Stroke (mm)	Installation height (mm)
eT-Lift-eco 30-60	308	156	1700	2900	2100	3400	2700	4200
eT-Lift-eco 80-250	348	156	1700	2900	2100	3400	2700	4200

Technical changes reserved. | Further versions available.

Technical drawing

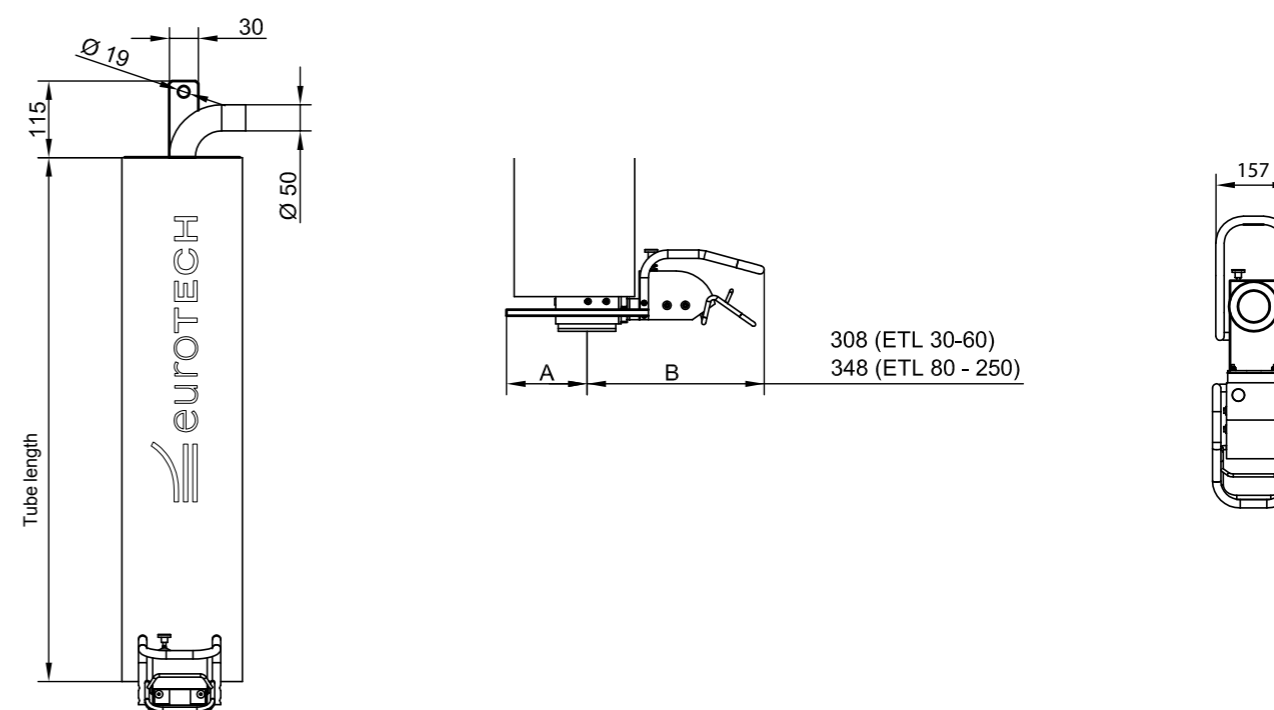

General information

This eT-Lift is used for large lifting heights. The base unit of the eT-Lift-eco is equipped with a rigid or flexible operating handle that is modified in length and design. It permits picking up loads from shelves at greater heights or from tall stacks.

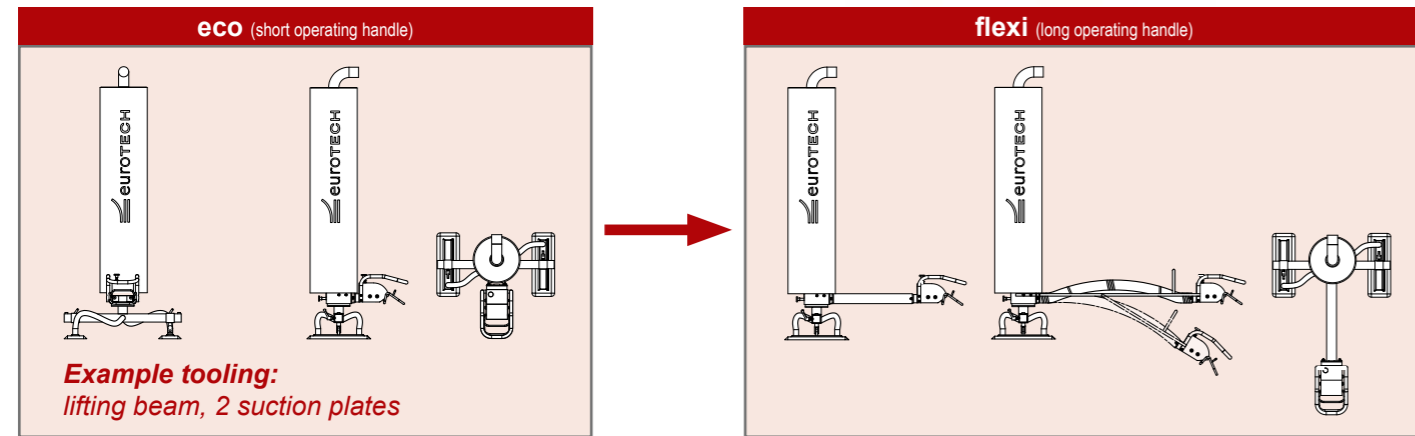
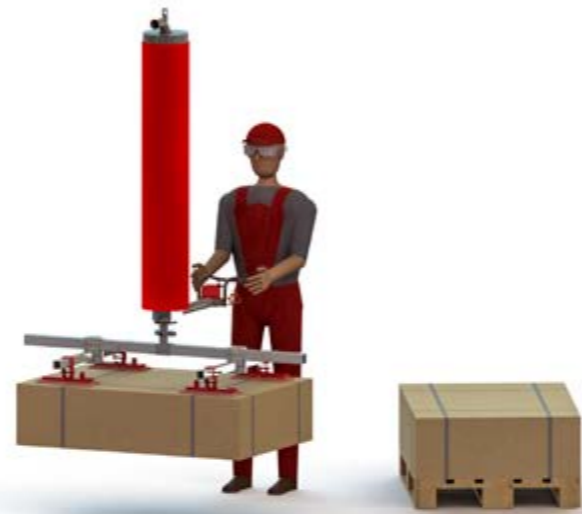

Technical data / Order data

Extended operating handle	Dimensions of control handle (mm)			Art.-No.
	A	B	C	
bendable	300	500	-	M011305
bendable	500	300	-	M011461
rigid	-	-	300	M011304
rigid	-	-	500	M011531
rigid	-	-	1000	M011532

Technical changes reserved. | Further versions available.

Technical drawing

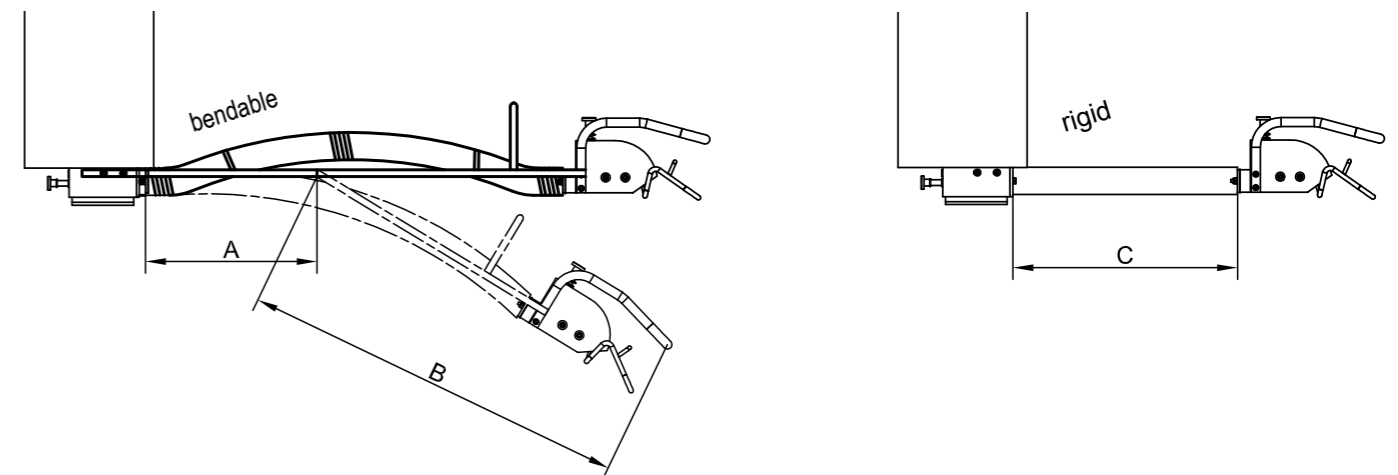

Tooling

Type	Description	Art.-No.
eT-Lift, lifting beam, 1x 50×50×4 – 2000, 4x 40×40×4 – 800, 8x 120×300	1x main beam, steel , 50×50×4 – 2000 mm      8x flat suction cups 120×300 mm 4x cross beams, aluminum, 40×40×4 – 800 mm      1x quick-change mechanism  Suitable for lifting flat loads such as chipboards, plasterboards, etc. with maximum dimensions of up to 1500 mm×3000 mm.  The cross beams and the individual suction cups can be moved. The tool has a maximum carrying capacity of 250 kg.	B009504
eT-Lift, lifting beam, 1x 40×40×4 – 500 2x 120×300	1x main beam, aluminum tube 40×40×4 – 500 mm      2x flat suction cups 120×300 mm  Suitable for lifting cardboard boxes or smaller wood panels. The tool has a maximum carrying capacity of 125 kg.	B009511
eT-Lift, lifting beam, 1x 50×50×4 – 1800, 2x 40×40×4 – 800 4x 120×300	1x main beam, steel , 50×50×4 – 1800 mm      4x flat suction cups 120×300 mm 2x cross beams, aluminum, 40×40×4 – 800 mm      1x quick-change mechanism  Suitable for lifting flat loads such as chipboards, plasterboards, etc. with maximum dimensions of up to 2100 mm×2800 mm.  The cross beams and the individual suction cups can be moved. The tool has a maximum carrying capacity of 250 kg.	B009520
eT-Lift, lifting beam, 1x 40×40×4 – 1200, 2x 120×300	1x main beam, aluminum, 40×40×4 – 1200 mm      1x quick-change mechanism 2x flat suction cups 120×300 mm  Suitable for lifting flat loads such as chipboards, plasterboards, etc. with maximum dimensions of up to 1500 mm×3000 mm.  The cross beams and the individual suction cups can be moved. The tool has a maximum carrying capacity of 125 kg.	B009516
eT-Lift, bag suction pad, oval design , 200 × 300	Oval suction pad with plugged sponge rubber seal, suitable for the transport of bags including interior support and quick-change mechanism.	M011542
eT-Lift, bag suction pad, oval design , 200×380	Oval suction pad with plugged sponge rubber seal, suitable for the transport of bags including interior support and quick-change mechanism.	M011307
eT-Lift, bag suction pad, oval design , 250×500	Oval suction pad with plugged sponge rubber seal, suitable for the transport of bags including interior support and quick-change mechanism.	M011309
eT-Lift, swivel drive 90° , max. 250 kg	Manual swivel drive 90° for tube lifters up to 250 kg. Design: galvanised steel	M011308
eT-Lift, load hook with vacuum compensation valve	The load hook is ideal for lifting buckets, canisters or similar, including quick-change mechanism.	M011827
eT-Lift, side channel blower	Vacuum generator for tube lifter of type eT-Lift-eco / -flexi, voltage 3×400 V, 50/60 Hz 3 kW	B009474
eT-Lift, quick-release valve, short (eco)	Quick-release valve for tube lifter type eT-Lift-eco. Enables very quick and easy release of the load from the suction cups. (cannot be retrofitted!)	M011776
eT-Lift, quick-release valve, long (flexi)	Quick-release valve for tube lifter type eT-Lift-flexi. Enables very quick and easy release of the load from the suction cups. (cannot be retrofitted!)	M011779
eT-Lift, vacuum hose type BVH 50	The vacuum hose of the BVH-F series is made of PVC with reinforcement PVC spiral, and it is suitable for vacuums up to -515 mbar. The hose has a smooth inside and a PVC spiral on the outside. The inner diameter is 50 mm. The temporary temperature resistance is at ±0 to +70° C. Weight: 540 g/m	M007272

Technical changes reserved. | Further tooling available.

Product pictures

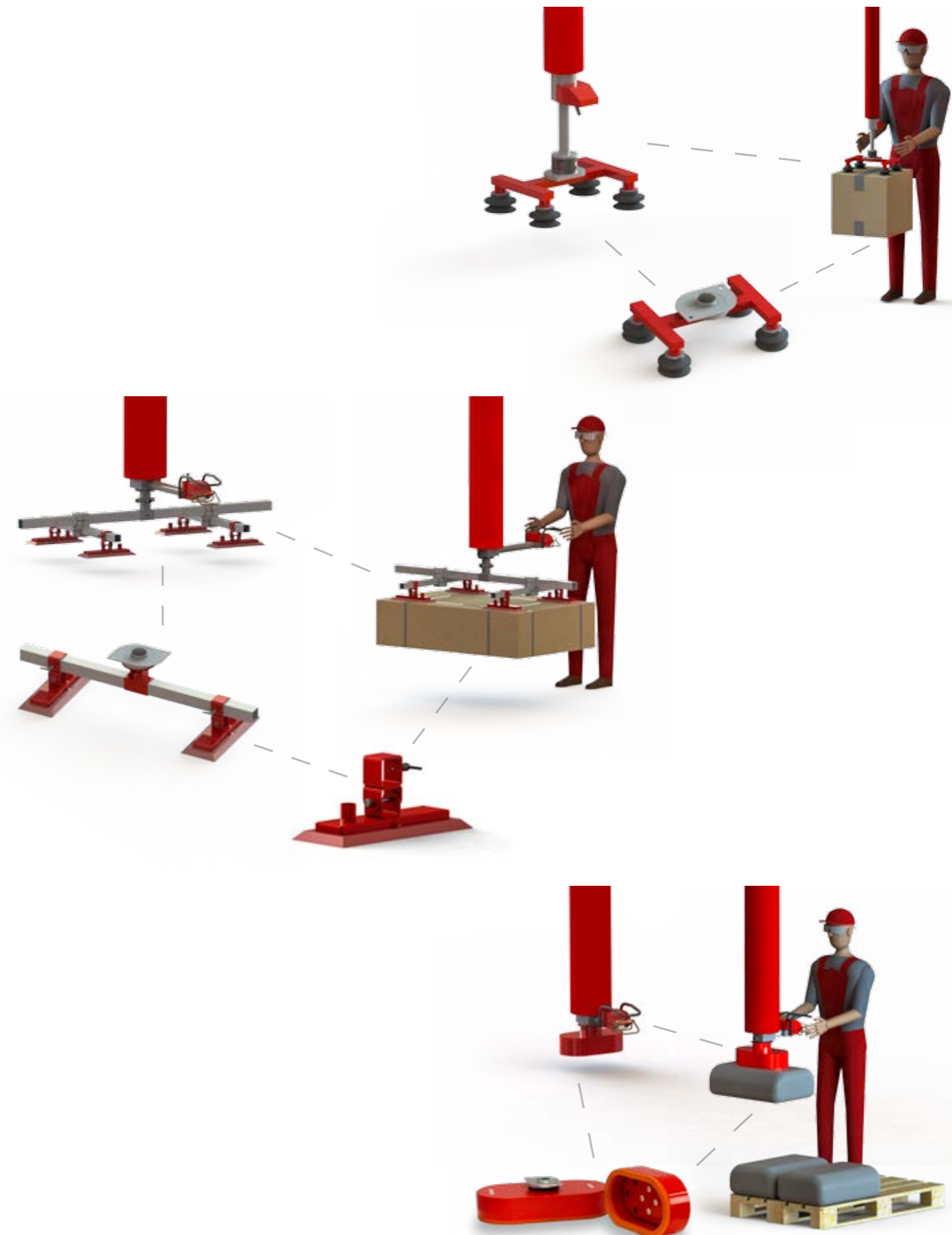



## — General information —

At **EUROTECH**, you receive the right crane solution for your **eT-Lift** tube lifter. Pillar jib cranes with a slewing range that is specifically adjusted to your needs or lightweight suspended crane systems with crane rails for a horizontal change of position round out and simplify work with the **eT-Lift**.

# SIMPLY...

...ask about this as well, when you enquire next about the **eT-Lift**...



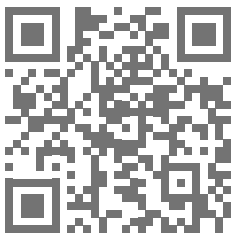

## **EUROTECH** Vertriebs GmbH

Dammstr. 1 Telephone: +49 7433 90468-0  
72351 Geislingen Fax: +49 7433 90468-13  
GERMANY E-Mail: [info@euro-tech-vacuum.de](mailto:info@euro-tech-vacuum.de)  
Internet: [www.euro-tech-vacuum.com](http://www.euro-tech-vacuum.com)

Art.-Nr.: BRO.01.2016.V1.en