

# Fravol

woodworking machines

**BEE**  
**SMI 45**



fravol.it



## Vantaggi Advantage

- Vasca colla con Teflon®  
Glue pot with Teflon®
- Taglio del bordo in rotolo PVC 2÷3 mm  
Guillotine for PVC 2÷3 mm
- Rullo motorizzato  
Pressure roller driven
- Refilatore con indicatore di posizione  
Heavy duty bevel trim unit with a single digital reader
- Raschiacolla  
Glue Scraping

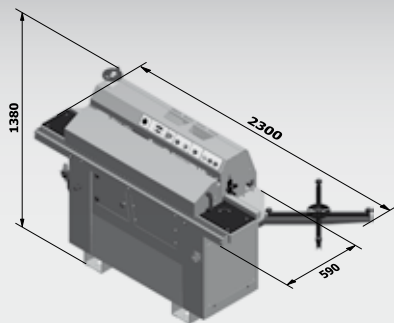

Spessore pannello - Panel thickness  
Espaisseur panneau - Werkstückdicke  
Espesor panel

**13 ÷ 45 mm**

Voltaggio - Voltage  
Voltage - Spannung  
Voltaje

**220/380 V  
50/60 Hz - 3 Ph + N**

Larghezza pannello - Panel width  
Largeur Panneau - Werkstücklänge  
Largo panel

**min. 65 mm**

Lunghezza pannello - Panel length  
Longeur panel - Werkstücklänge  
Largo panel

**min. 140 mm**

Altezza bordo - Edge width  
Largeur chant - Kantenbreite  
Anchura canto

**13 ÷ 48 mm**

Potenza installata - Installed power  
Puissance installée - Leistung installierte  
Potencia instalada

**1,94 Kw**

Spessore bordo - Edge thickness  
Espaisseur chant - Kantendicke  
Espesor canto

**0,4 ÷ 3 mm**

Pressione d'aria - Air pressure  
Pression de l'aire - Druck  
Presión

**6 bar**

Avanzamento - Feed  
Avancement - Vorschub  
Avance

**5 m/min**

Peso - Weight  
Poids - Gewicht - Peso

**260 Kg**



### IT Macchina semiautomatica

per la rifilatura d'angoli su pannelli bordati in melaminico, impiallacciatura, PVC o ABS a spessore, con profili piani o soft-formati.

### EN Semi-automatic machine

for trimming corners on panels edged in melamine, veneer, PVC or ABS with flat or soft-formed profiles.

### FR Machine semi-automatique

pour le rognage à épaisseur d'angles sur des panneaux bordés en mélamine, plaquage, PVC ou ABS, avec profils plats ou soft-formés.

### DE Halbautomatische Maschine

für das Nachschneiden von Ecken an Platten mit Kanten aus Melamin, Furnierholz, entsprechend starkem PVC oder ABS, mit flachen oder softgeformten Profilen.

### ES Máquina semiautomática

para perfilar los ángulos de tableros chapeados con recubrimiento en chapa, PVC o ABS de distintos espesores, con perfilados planos o soft-formatados.

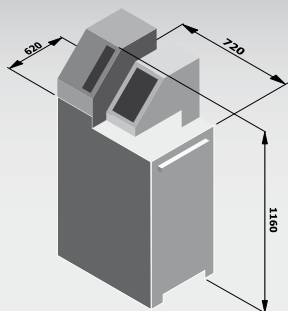

Spessore pannello - Panel thickness  
Espaisseur panneau - Werkstückdicke  
Espesor panel

**10 ÷ 45 mm**

Voltaggio - Voltage  
Voltage - Spannung  
Voltaje

**230 V**  
**50/60 Hz - 1 Ph + N**

Larghezza pannello - Panel width  
Largeur Panneau - Werkstücklänge  
Largo panel

**min. 130 mm**

Lunghezza pannello - Panel length  
Longeur panel - Werkstücklänge  
Largo panel

**min. 300 mm**

Altezza bordo - Edge width  
Largeur chant - Kantebreite  
Anchura canto

**13 ÷ 48 mm**

Potenza installata - Installed power  
Puissance installée - Leistung installierte  
Potencia instalada

**0,50 Kw**

Spessore bordo - Edge thickness  
Espaisseur chant - Kantendicke  
Espesor canto

**0,4 ÷ 3 mm**

Pressione d'aria - Air pressure  
Pression de l'aire - Druck  
Presión

**6 bar**

Avanzamento - Feed  
Avancement - Vorschub  
Avance

**1 m/min**

Peso - Weight  
Poids - Gewicht - Peso

**100 Kg**

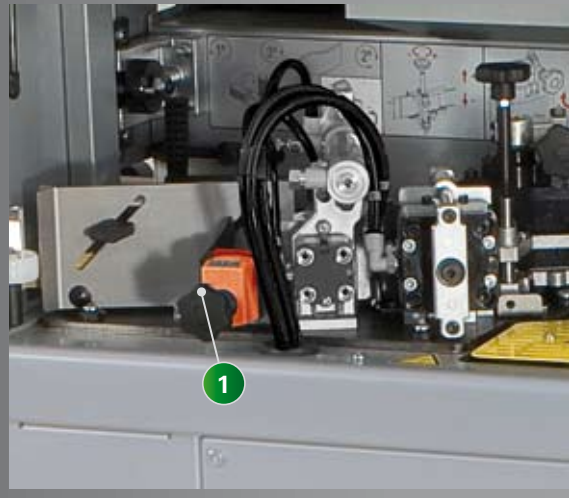

1  
 IT Indicatore di posizione  
 EN Position indicator  
 FR Indicateurs de position  
 DE Positionsanzeige  
 ES Indicadores de posición

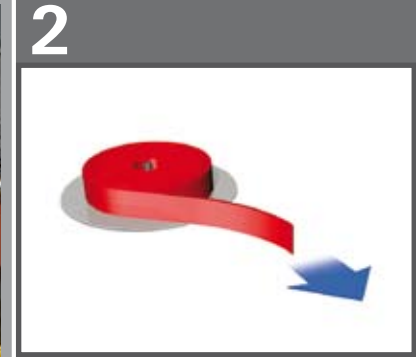

2  
 IT Caricatore automatico bordi  
 EN Edge-Feeding  
 FR Charger le chant  
 DE Kante zuführen  
 ES Alimentación del canto

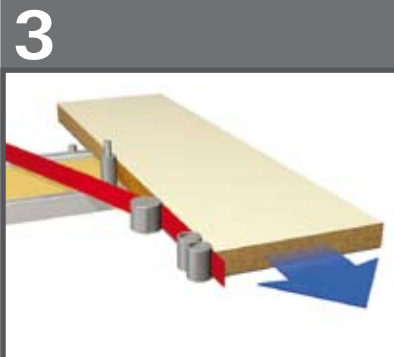

3  
 IT Incollaggio  
 EN Pressure Zone  
 FR Encollage  
 DE Anleimen  
 ES Encolado

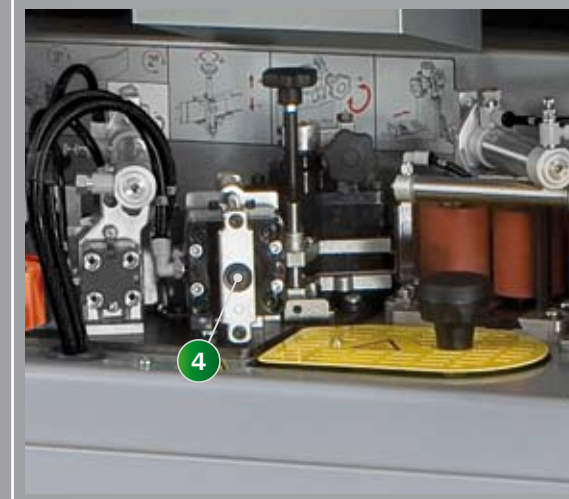

4  
 IT Intestatore  
 EN End-Trimming  
 FR Abouters  
 DE Kappen  
 ES Retestador



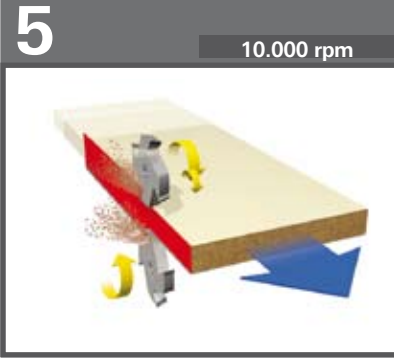
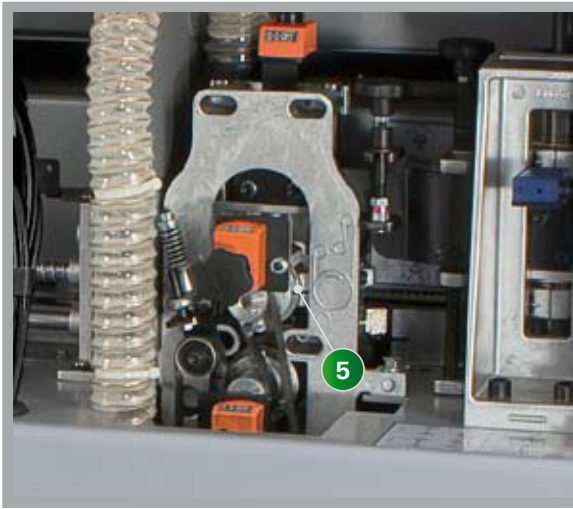

- IT Rifilatore sovrapposto
- EN Top-Bottom Roughing Unit (Flush)
- FR Dégrossés
- DE Vorfräsen (Planfräsen)
- ES Desbastador

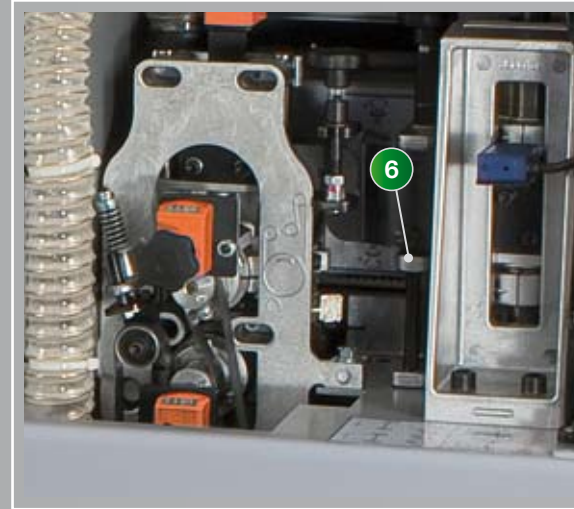

- IT Raschia colla
- EN Scraping Glue
- FR Racleur Colle
- DE Nachputzen Lime
- ES Rascador de Cola

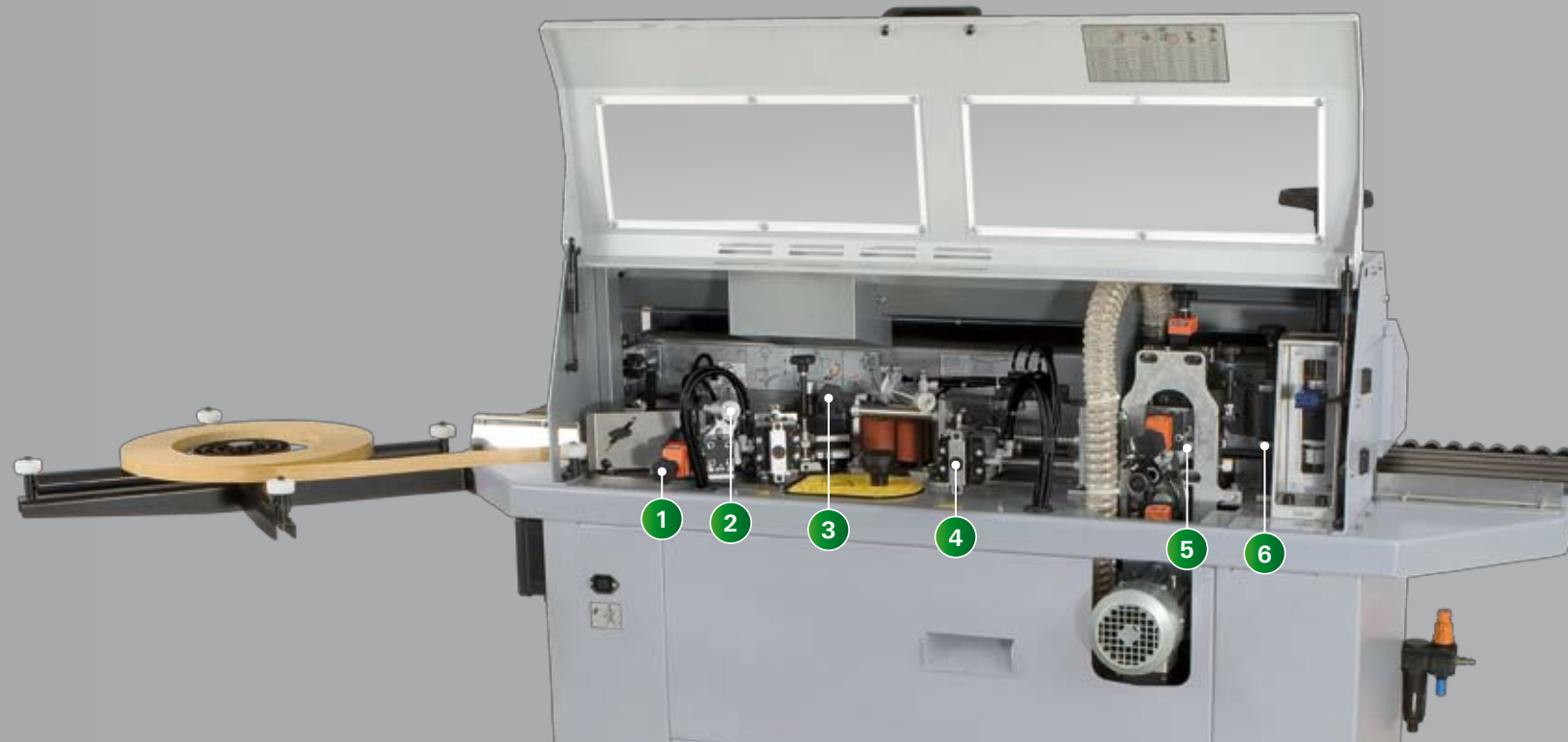

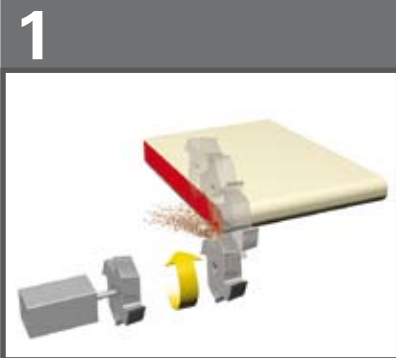

- 1
- IT Pressore pezzi
  - EN Pressure panels
  - FR Pièces de pression
  - DE Drucktragende
  - ES Partes de presión

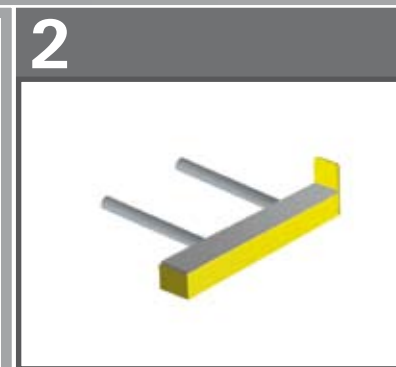

- 2
- IT Supporto estensibile per pezzi di grandi dimensioni
  - EN Extensible guide for big pieces
  - FR Support extensible pour les pièces volumineuses
  - DE Erweiterbare Unterstützung für große Werkstücke
  - ES Soporte extensible para piezas grandes

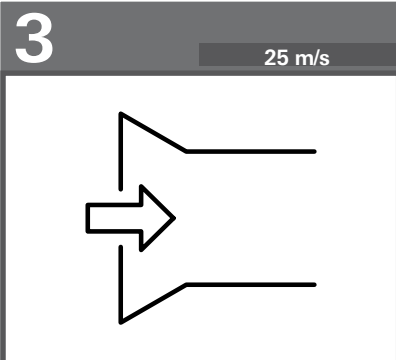

- 3
- IT Aspirazione centralizzata
  - EN Central dust extraction
  - FR Extraction de poussière central
  - DE Zentrumsabsaugung
  - ES Extracción de polvo central



note

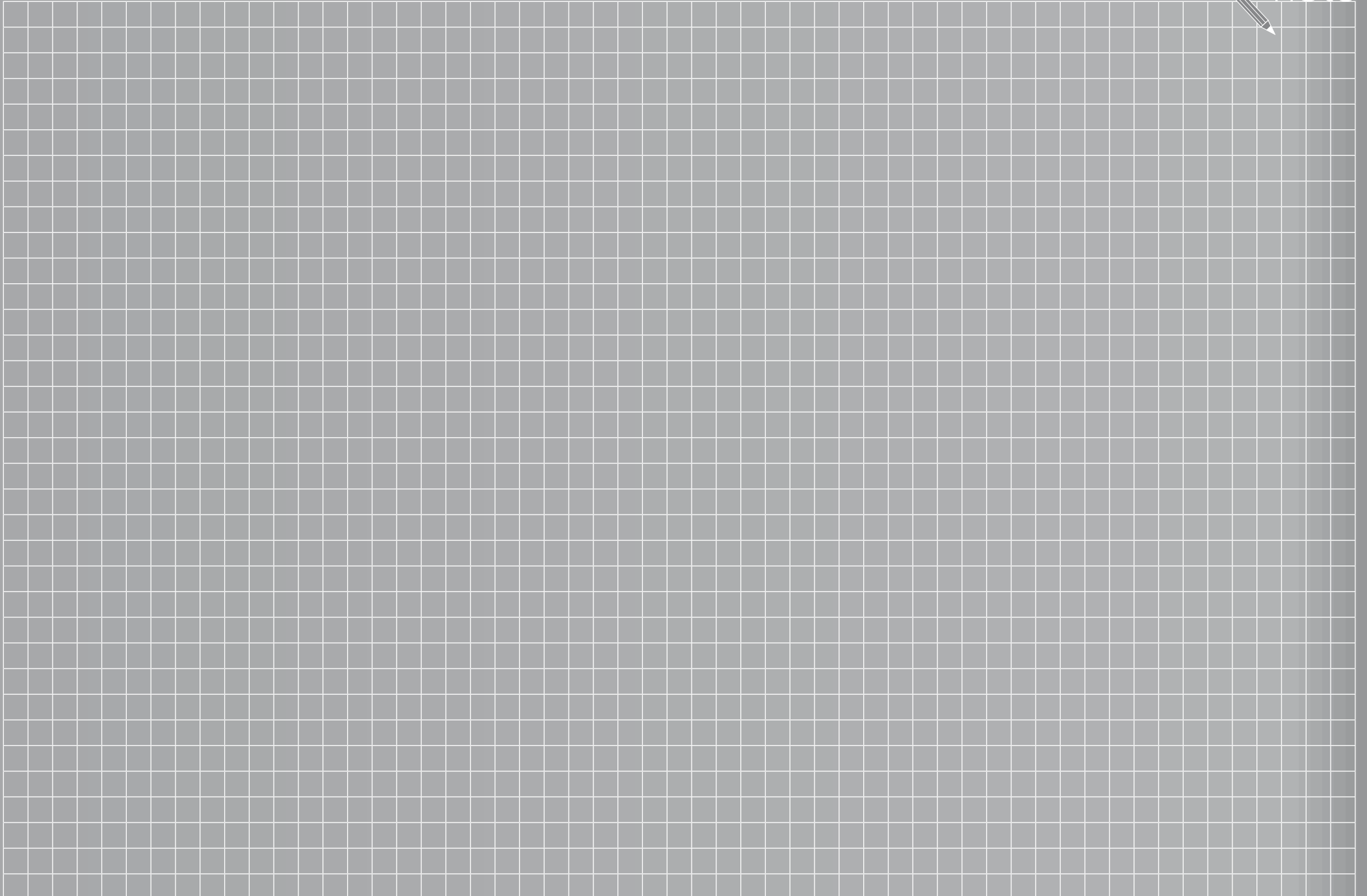

0 1 2 3 4 5 6 7 8 9 10 11 12 13 14 15 16 17 18 19 20 21 22 23 24 25 27 28



# Fravol

macchine per la lavorazione del legno  
manufacture of woodworking machines

uff. e dep.: via A. Niedda, 6 - 35010  
Peraga di Vigonza - (PD) - Italy  
tel. +39 - 049 725085 - 725888  
fax +39 - 049 8931635  
[www.fravol.it](http://www.fravol.it) [fravol@fravol.it](mailto:fravol@fravol.it)