

The universal one... **HUBTEX.**

- Capacities from 1.5 to 10.0 tonnes
- Lift heights up to 7500 mm



Diesel/Gas Fourway
Sideloader

... universal and robust

The compact HUBTEX fourway sideloader with diesel or gas drive is preferably used in external storage areas of the building material, timber and steel industry. The trucks are available as gas or diesel driven versions and set standards for safety and manoeuvrability due to their innovative steering system.



» Capacities from 1.5 to 10.0 tonnes

» Proportional valve technology
Infinitely variable and smooth operation of all lifting mast functions

» Fork carriage tilt (instead of mast tilt)
for high derated capacities and safe handling at high lift heights

» Solid and robust lifting masts with high capacities also for large load centres

» Sensitive single levers for operation of all mast functions



» 3 in 1
Frontloader, sideloader and fourway sideloader

» Hydrostatic all-wheel drive ensures optimal traction on gradients and in winter time

» Diesel/gas drive with the latest engine technology

» Indoor and outdoor application for combined or pure outdoor use

» Fourway technology allows lengthwise, crosswise and circle drive

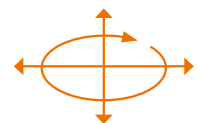



Optimize your warehouse capacity!

Due to the use of HUBTEX sideloaders, narrow aisles can be passed through without any problems and the distance between the rack rows reduced to a minimum. In this way, space is created for additional rack rows and new warehouse capacity.

- up to 100% more storage space
- fast, safe and efficient
- less damage to merchandise /less breakage

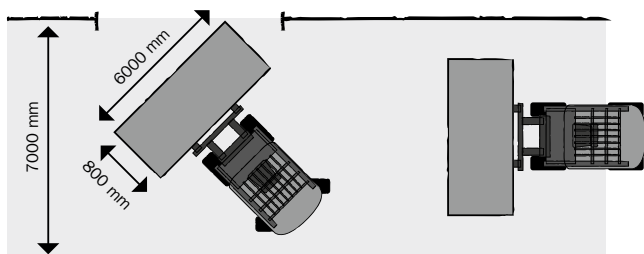
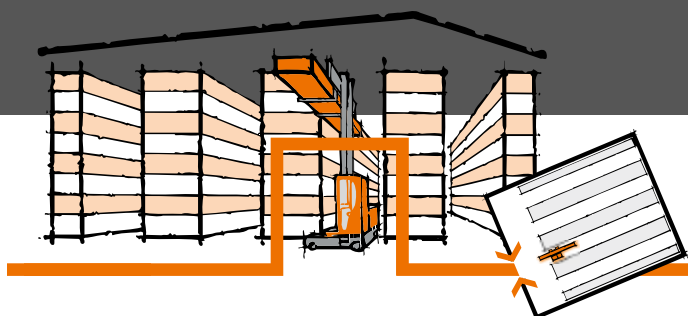
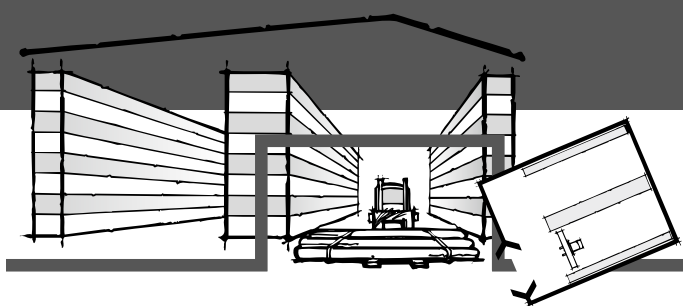

without HUBTEX

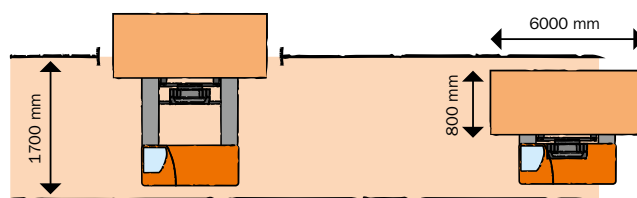

with HUBTEX



HUBTEX.

The HUBTEX series in detail:

HUBTEX fourway sideloaders combine frontloader, sideloader and fourway sideloader. They are suitable for all-purpose applications for the transport of long loads in narrow aisles or as conventional frontloader for pallet and block stacking.

The series at a glance:

- 3049 series
- 3050 series
- 3051 series
- 3052 series

“Let everybody do what he can do best”

(Cicero)





Series	3049
Capacity (t)	1.5 to 3.0
Load bed width (mm)	1000 / 1200
Lift height (mm)	up to 6500
Frame length L (mm)	2000
Load bed opening RA (mm)	1230
Tyres	Elastic
Motive power	Diesel / Gas
Cabins	Standard

Series	3050
Capacity (t)	3.0 to 5.0
Load bed width (mm)	1200 / 1400
Lift height (mm)	up to 7500
Frame length L (mm)	2190
Load bed opening RA (mm)	1340
Tyres	Elastic
Motive power	Diesel / Gas
Cabins	Standard / Comfort

Series features

The very robust and compact fourway sideloaders have been developed by HUBTEX for indoor and outdoor use. Due to their hydrostatic all-wheel drive with separately activable differential lock, they are ideally suited for poor ground or floor conditions and semi-solid ground (even for slippery surfaces like ice and snow).

The fourway steering allows optimal handling of long and bulky loads and efficient use of storage space. Their superior steering system ensures shortest changeover time from lengthwise to crosswise drive. The powerful diesel and gas engines easily meet the current environmental standards and are optimized with regard to ease of maintenance and service.

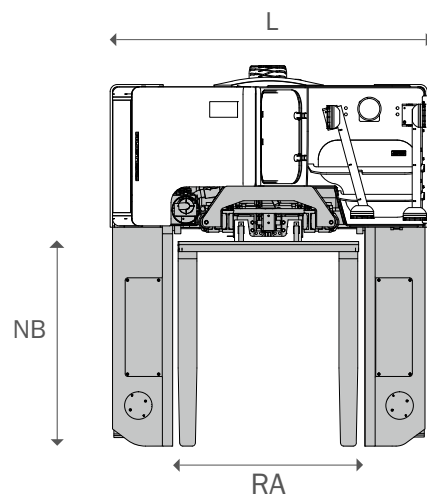

Series	3051
Capacity (t)	5.0 to 8.0
Load bed width (mm)	1200 / 1400
Lift height (mm)	up to 7500
Frame length L (mm)	2800
Load bed opening RA (mm)	1600
Tyres	Elastic
Motive power	Diesel / Gas
Cabins	Standard / Comfort

Series	3052
Capacity (t)	9.0 to 10.0
Load bed width (mm)	1200 / 1400
Lift height (mm)	up to 7500
Frame length L (mm)	3000
Load bed opening RA (mm)	1800
Tyres	Elastic
Motive power	Diesel / Gas
Cabins	Standard / Comfort





HUBTEX.

Equipment features of the series in detail

All HUBTEX trucks are designed to exactly match the users application and requirements.

HUBTEX offers a wide range of options to ensure the equipment operates as safely and efficiently as possible.



Equipment features in detail

The right equipment for every application

» Drive unit

Diesel and gas (LPG) engines made by well-known manufacturers are optionally available for all universal fourway siders. They comply easily with the current worldwide environmental standards. The good accessibility of the engines and drive components due to the installation of robust maintenance covers improves the ease of service and helps to reduce costs. Due to efficient cooling of the engines,

the maximum possible service life is achieved while the oil consumption is kept low.

» Proportional valve technology

The proportional valve technology used by HUBTEX allows the sensitive actuation of all lift mast functions without jerks.



Diesel engine



Gas tank



Replaceable gas bottles

» Soot particle filter

HUBTEX diesel vehicles can be equipped with soot particle filters for the emission reduction. Diesel particle filters with integrated fuel or electric burners as well as diesel particle filters with replaceable cartridge are optionally available.



» Gas tank and replaceable gas bottles

Refillable tank and gas bottles are safely installed within the vehicle frame. For 3050 series & up there is space for a spare gas bottle to be carried. Refillable gas tanks can have a fuel level indicator fitted.



» Tyres and internal hydraulic hoses

The soft elastic tyres are particularly suitable for poor floor and ground conditions and increase the driving comfort at the same time. Since the hydraulic hoses for the travel motors are located in the load bed, the components are protected against damage.



» Fourway all-wheel technology

In **lengthwise drive**, the HUBTEX DQ series can quickly transport long material through narrow doors and aisles. In **crosswise drive**, the HUBTEX DQ series can be used as conventional frontloader. **Circle drive** enables a fast turning of the truck.

This agility will be a big advantage and can help you by saving up to 50% of valuable floor space.

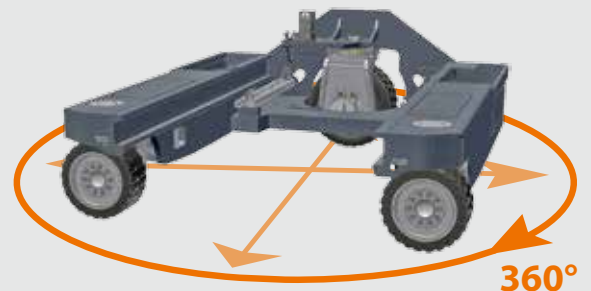

High-Performance-Steering (HPS)

- » up to 60% faster changeover from longitudinal to crosswise operation compared to conventional steering systems
- » up to 30% smaller turning radius by means of the load wheels

(available for the 3049, 3051 and 3052 series)

» Lighting

“See and be seen” is the motto of this feature. HUBTEX offers several lighting options within the chassis frame for optimal safety on your company premises.

» Lift masts and fork carriages

Stable and strong lift masts with internally reeved hydraulics (No hose reels) are manufactured "in-house" and have a high reserve of load capacity. HUBTEX manufactures fork carriages for the safe and efficient handling of all loads. The hydraulic fork adjusting device and a side shifter are optionally available for all HUBTEX sideloaders.



» Two-stage free-view lift mast (Simplex)

Your advantage: The cost-effective mast version provides an optimal degree of all-round visibility. Thus, the load pick-up operation is improved.



» Standard fork carriage type I

For the handling of pallets and rigid long loads or stillages with fork pockets.

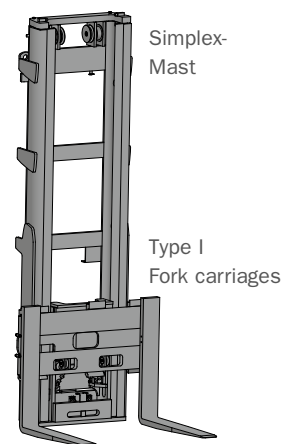

» The fork carriages can be combined with all lift masts.

» Attached fork carriage with two additional forks

For trucks with a short type I carriage a quickly detachable long carriage is available allowing the truck to temporarily lift very long loads. Four forks can at the same time be utilized.





➤ **Two-stage lift mast with full free lift (Duplex)**

Your advantage: The closed height of the mast is also the maximum transport height in the free lift range. This is, above all, advantageous to the handling of loads in the case of passages and limited hall heights.

➤ **Three-stage lift mast with full free lift (Triplex)**

Your advantage: lowest overall height, in the retracted condition, for great lift heights.

➤ **Spreaded fork carriage type II**

For the handling of all sorts of pallets and long loads. The HUBTEX fork carriage type II has an extremely low vertical height which ensures the best possible utilization of the available ceiling height (up to a maximum of 3000 kg).

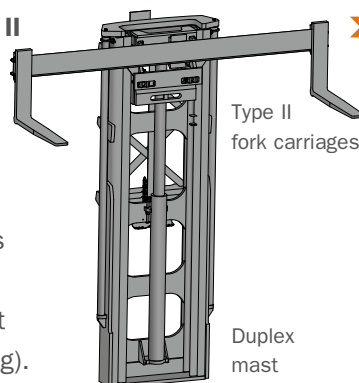

➤ **Spreaded fork carriage type III**

For the handling of all sorts of pallets and long loads. The HUBTEX fork carriage type III is characterized by its stable and robust design, and has been tried and tested in industrial use over decades.

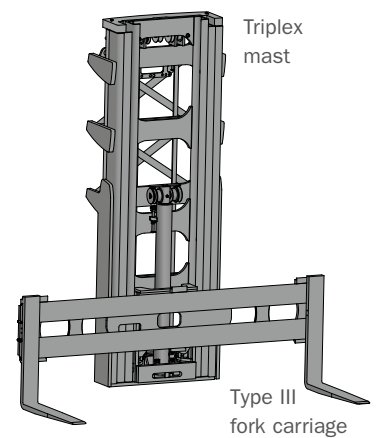



» Forks

HUBTEX offers forks for every application. As an essential vehicle component, they have to meet particularly high requirements. Due to the use of high-quality products, least possible wear and high load capacities are ensured.

» Height-adjustable forks (level compensation)

To compensate for uneven floor or ground, lifting forks are available for all load capacities, also in combination with telescopic forks.



Normal (base) position



Extended telescopic forks

» Telescopic forks

For the loading and unloading of lorries from one side or for the double-deep storage of goods in rack systems, the HUBTEX sideloaders can be equipped with telescopic forks (manual or hydraulic) which are available in all lengths and load capacities.

» Knife type forks (Full taper)

Knife type forks are available at extra cost for picking up loads in extremely narrow spaces. (without illustration).

» Cabin

» Ergonomics

The spacious and ergonomically designed driver cabin offers plenty of elbow room and optimal all-round visibility. The vibration damped cabin as well as the full suspension, multiply adjustable comfort seat provide for smooth working without getting tired and preserve the driver's health.



» Cabin versions

The standard cabin is also available as comfort version to give the driver more elbow room and legroom. It provides an increased degree of driving comfort.

Standard cabin Q890,
length 1080 mm x width 890 mm

» HUBTEX information terminal

The modern information terminal allows the reading out of direction of motion, tank capacity, running hours, maintenance intervals, pre-heating time, filter check and many more.



Comfort cabin Q1000,
length 1080 mm x width 1000 mm
with 150 mm cabin overhang

further options ...

➤ Surface protection

For the protection of sensitive materials, the load beds can be provided with surface coating if desired. This coating is available as solid panel or as individual semi-circular elements.



➤ Further accessories

- guide rollers,
- aisle recognition,
- lockable door,
- cabin heating,
- additional working headlamps,
- beacon,
- audible warning signal,
- additional screen wipers,
- ...and many more.



Rental vehicles

Rental or financing

HUBTEX holds an equipment fleet of 50 vehicles ready for short or long-term rental. This is one of the largest sideloader fleets offered for rental on the market. Thus, we can offer you a suitable solution for your application, as well.

Apart from that, we are pleased to offer you the appropriate financing model for your new HUBTEX sideloader. Our range of options from hire purchase to full rental which includes maintenance and repair is available to suit our customers needs.

Your HUBTEX moves on and on

Who should understand your HUBTEX better than we do? Apart from excellent service, HUBTEX Service offers you long-term investment security which is indeed “the manufacturer’s know-how”.



➤ More HUBTEX

Excellently trained technicians whose knowledge and know-how always reflects the latest state of the art.

➤ More service

- Exactly calculable maintenance costs due to factory guidelines with regard to service times.
- No unnecessary time required for fault finding due to latest diagnostic tools.

- Highest quality due to the exclusive use of original spare parts.
- Fastest possible solution of problems by comprehensive factory support.
- Technicians have the welder's qualification certificate which allows them to perform safety-relevant work tasks on their own.

➤ More value

- Due to the exclusive use of original spare parts, your truck remains an original HUBTEX.
- Our service experts offer you maximum transparency regarding the development of your maintenance costs.
- Customized maintenance concepts provide you with a clearly calculable cost structure.
- On request, we analyze your present maintenance costs and show you where potential for savings exists.

➤ More safety

You can be sure that all safety-related equipment of your truck is checked by competent, specialized technicians according to the latest guidelines at least once per year.

HUBTEX at your disposal in more than 60 countries all over the world.



HUBTEX Maschinenbau GmbH & Co. KG

Industriepark West

Werner-von-Siemens-Str. 8

36041 Fulda, Germany

Telephone: +49-661-8382-0

Fax: +49-661-8382-120

info@hubtex.com

www.hubtex.com



**Further HUBTEX products
at a glance:**

- Electric Multidirectional Sideloaders
- Electric Fourway High-Lift Trucks
- Sideloaders
- Order Picking Systems
- Glass Transport Systems
- Heavy-Duty Compact Frontlifts
- Fork-Lift Reach Trucks
- Special-Purpose Vehicles
- Heavy-Duty Transport Vehicles
- Second-Hand and Rental Equipment