



# WELDED STEEL CHAINS

ISO DP6972 ANSI B29-16

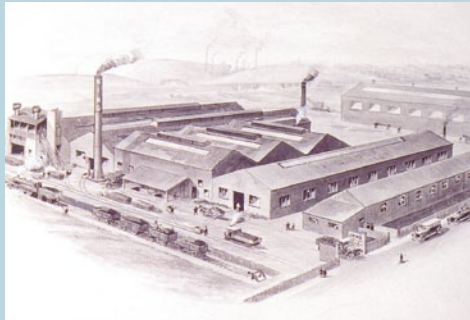


 *Linking you to EXCELLENCE since 1926*

**JOHN KING**



# JOHN KING & COMPANY



Climax Works 1930's



Chain Assembly 1960's



New Climax Works 2000's

## Company History and Qualifications

The John King Company was established in Leeds, England in 1926. Early success was achieved in the manufacture of mechanical handling equipment for the rapid mechanisation of the coal industry. In these early days conveyor chain was generally of cast link construction. The Company therefore has unrivalled experience in the production of highest quality cast link chains in ductile irons and steel under the "Climax Quality Brand". JOHN KING are undoubtedly the world leaders in this range of conveying chains.

Although cast link chains remain an important part of the JOHN KING programme, the company has progressively expanded the product range to encompass chains of other constructions and manufacturing techniques including Welded steel chains, engineered steel chains, forged fork link chains and Engineering plastic chains. Today JOHN KING offer the widest range of conveyor chains of any manufacturer which makes them unique in being able to offer an infinite number of chain types in a variety of materials and constructions for a multiplicity of industry mechanical handling applications.

In recent years it has been JOHN KING's strategy to develop the Company into a global business. This has seen the establishment, in addition to the United Kingdom, of a chain production plant in the US. John King USA Inc from their plant in East Peoria (IL) are well equipped with the manufacturing equipment for component production and assembly processes for high quality chain production serving North and South America. To provide best service in export markets the companies has warehousing and distribution worldwide and maintain ambition plans to expand the network further in the future.

All products are manufactured within the dictates of the Company's quality management according to ISO 9000 establishing consistent and high quality products and ensuring performance reliability and extended service life.

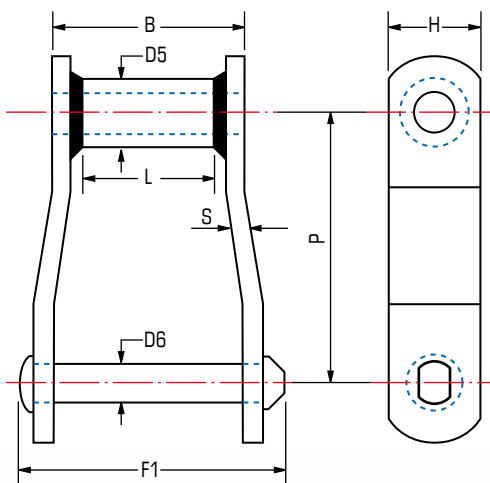
## CONTENTS

Offset Sidebar Welded Steel Chains **03** | Extra Heavy-Duty Welded Steel Chains **04** | King M Series Equivalent Welded Steel Chains **05** | K1 attachments and A1 attachments (If one side) **06** | K2 attachments and A2 attachments (If one side) **06** | A22 attachments **07** | Special Slotted A22 for Waferizer Chains **07** | S1 attachments **08** | F4 attachments **08** | H1 attachments **09** | H2 attachments **09** | R2 attachments **10** | RR2 attachments **10** | RF2 attachments **11** | RF12 attachments **11** | Log Cradle For Single Strand Chains **12** | Special Slasher attachments **12** | Welded Steel Universal Top **13** | Welded Steel Chains with U.H.M.W. Cap **13** | Steel Roll Top Chain with Nylon Rollers **13** | Welded Steel Drag Chains **14** | Reverse Barrel Wide Series Drag Chains **15** | Heavy Duty Cobra Drag Chains **16** | Wing attachments **17** | Attachments C-1/2, C-1, C-3, C-4 **18** | Crusader Heavy Duty Steel Drag Chains (WH X) **19**



## Offset Sidebar Welded Steel Chains

JOHN KING Welded steel chains have become North America's preferred choice in many materials handling applications. The simple and robust construction offers a superior method of conveying most materials. The narrow series employs an offset side plate, a bush circumferentially welded to the side plate with a pin subject to heavy interference fit of either a riveted or cottared construction. The standard KING chain has heat treated parts, uprated versions with induction hardened pin, bush and side plate offer optimum performance in high duty applications. The success of this series in the paper and pulp industry notably on log decks with high impact and abrasion is testament to this high performance product.



### Offset Sidebar Welded Steel Chains

Chain Number	P	Breaking Load	Average Weight	Over-All Pin & Cotter	Between Sidebars	Sidebars		Rivets	Bushings	Length of Bearing
						Thickness	Height	Diameter	Outside Diameter	
						S	H	D6	D5	
WH78	2.609	33,000	4.30	3.00	1.00	0.25	1.25	0.50	0.84	2.00
WH82	3.075	36,000	4.70	3.38	1.13	0.25	1.25	0.56	1.00	2.25
WH124	4.000	57,000	7.80	4.25	1.50	0.38	1.50	0.75	1.25	2.75
WH111	4.760	60,000	8.60	4.81	1.75	0.38	1.75	0.75	1.25	3.38
WH110	6.000	50,500	7.00	4.00	1.88	0.38	1.50	0.75	1.25	3.00
WH106	6.000	60,000	6.20	4.25	1.50	0.38	1.50	0.75	1.25	2.75
WH132	6.050	122,000	14.10	6.38	2.75	0.50	2.00	1.00	1.75	4.41
WH150	6.050	122,000	16.30	6.50	2.75	0.50	2.50	1.00	1.75	4.41
WH155	6.050	175,000	19.00	6.41	2.75	0.56	2.50	1.13	1.75	4.44
WH157	6.050	175,000	20.00	6.75	2.75	0.63	2.50	1.13	1.75	4.63
WH159	6.125	210,000	26.00	6.75	2.75	0.63	3.00	1.25	2.00	4.63
WH200	6.125	190,000	22.10	6.75	2.75	0.63	2.50	1.25	2.00	4.63

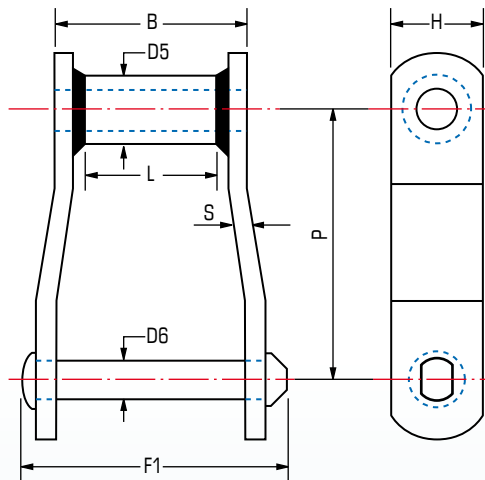
Add IBR or fully heat treated parts plus induction hardened barrels and rivets.





## Extra Heavy-Duty Welded Steel Chains

JOHN KING Extra heavy duty welded steel chains employ heavier link plates for increased wearing surfaces. The sizes and specifications ensure higher ultimate strength, superior impact resistance and extended service life. The addition of induction hardened sidebar surfaces, although available throughout the narrow series range, is typical in the XHD where sliding wear is often the major issue.



### Extra Heavy-Duty Welded Steel Chains

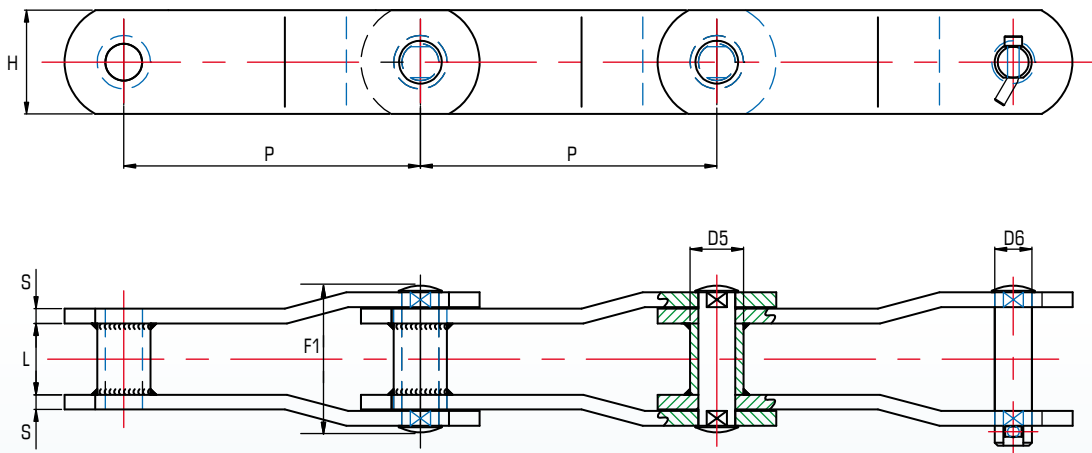
Chain Number	P	Breaking Load	Average Weight	Over-All Pin & Cotter	Between Sidebars	Sidebars		Rivets	Bushings	Length of Bearing
						Thickness	Height	Diameter	Outside Diameter	
						F1	L	S	H	
inches										
WH78XHD	2.636	36,000	6.30	3.38	1.00	0.38	1.25	0.56	1.00	2.00
WH82XHD	3.075	57,000	8.50	3.75	1.13	0.38	1.50	0.75	1.25	2.38
WH124XHD	4.063	122,000	14.60	4.88	1.50	0.50	2.00	1.00	1.63	3.00
WH106XHD	6.050	122,000	11.80	4.88	1.50	0.50	2.00	1.00	1.75	3.00
WH132XHD	6.050	122,000	15.30	6.75	2.75	0.63	2.00	1.00	1.75	4.66

Add IBR or fully heat treated parts plus induction hardened barrels and rivets.



## King M Series Equivalent Welded Steel Chains

John King order a unique range of welded steel chains dimensionally equivalent to M Series bush chains according to DIN8167. The chain offers all the benefits of the "offset" sidebar welded construction and can be accommodated in existing conveyors and operate on same sprockets. This allows the user a unique opportunity to improve reliability and service life without major alteration.

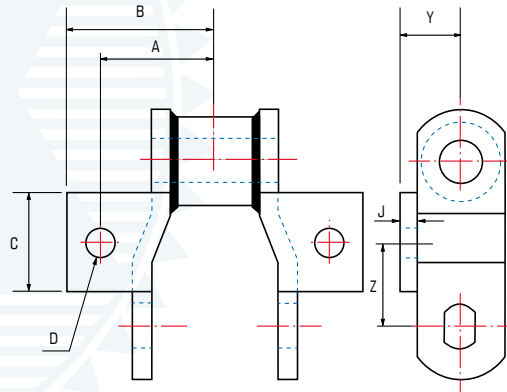


### King M Series Equivalent Welded Steel Chains

Chain Number	Pitch	F1	L	S	H	D6	D5	Breaking Load	Weight	
	P									
mm										
									kN	kg/m
WHM224/160	160	93	42	8	60	21	42	224	22.87	
WHM224/200	200	93	42	8	60	21	42	224	19.84	
WHM315/20	200	99	48	10	70	25	48	315	31.00	
WHM315/250	250	99	48	10	70	25	48	315	27.00	
WHM450/250	250	107	56	12	80	30	56	450	41.05	
WHM450/315	315	107	56	12	80	30	56	450	35.67	

\* IBR represents uprated timber specification with fully heat-treated components together with induction hardened barrel (bush) and pin.

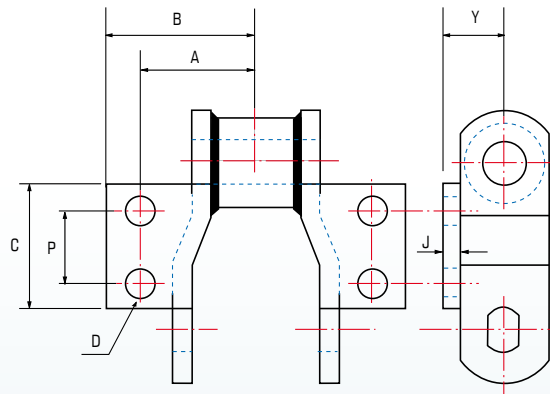
## K1 attachments and A1 attachments (If one side)



### K1 attachments & A1 attachments (If one side)

Chain Number	A	B	C	J	D	Z	Y	Average Weight
	inches							lbs/ft
WH78	2.00	2.50	1.25	0.25	0.38	1.25	0.88	5.50
WH78XHD	2.00	2.50	1.25	0.25	0.38	1.25	0.88	7.50
WH82	2.38	3.00	1.75	0.25	0.38	1.50	0.88	7.20
WH82XHD	2.38	3.00	1.75	0.38	0.38	1.50	1.13	11.00
WH124	2.63	3.25	1.75	0.38	0.38	2.00	1.13	11.70
WH124XHD	2.63	3.38	1.75	0.50	0.50	2.00	1.50	18.50
WH111	3.13	3.75	1.75	0.38	0.38	2.13	1.25	22.40
WH132	3.75	4.63	2.00	0.50	0.50	3.00	1.50	18.90
WH132XHD	3.75	4.63	2.00	0.50	0.50	3.00	1.50	19.80

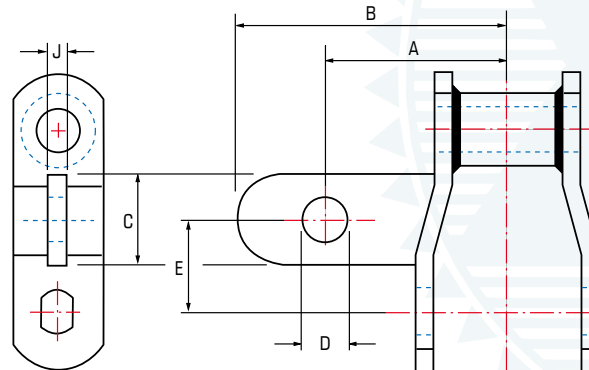
## K2 attachments and A2 attachments (If one side)



### K2 attachments & A2 attachments (If one side)

Chain Number	A	B	C	J	D	P	Y	Average Weight
	inches							ft/lbs
WH78	2.00	2.50	2.13	0.25	0.38	1.13	0.88	6.30
WH78XHD	2.00	2.50	2.13	0.25	0.38	1.13	0.88	8.30
WH82	2.13	2.75	2.25	0.25	0.38	1.25	0.88	7.60
WH82XHD	2.38	3.00	2.25	0.38	0.38	1.25	1.13	11.40
WH124	2.63	3.25	3.00	0.38	0.38	1.94	1.13	11.70
WH124XHD	2.63	3.38	4.00	0.50	0.50	1.94	1.50	18.50
WH111	3.13	3.88	4.00	0.38	0.38	2.31	1.25	12.40
WH132	3.75	4.50	4.25	0.50	0.50	2.75	1.50	19.80
WH132XHD	3.75	4.63	4.25	0.50	0.50	2.75	1.50	21.00

## A22 attachments

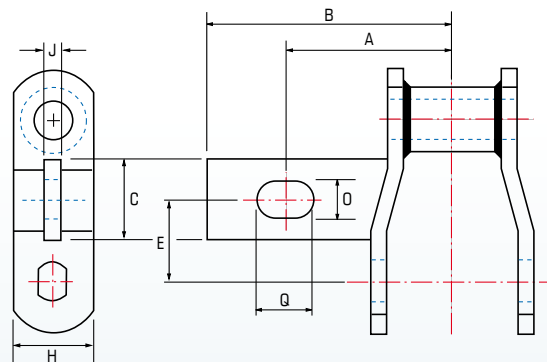


### A22 attachments

Chain Number	A	B	C	J	E	F	S	H	D	Average Weight
	inches									
WH78	2.00	2.63	1.25	0.25	1.25	-	-	-	0.44	4.90
WH124	3.00	3.88	1.75	0.38	2.00	-	-	-	0.56	8.75
WH111	3.50	4.38	1.75	0.38	2.38	-	-	-	0.56	10.62
WH106	2.75	3.63	1.75	0.38	3.00	-	-	-	0.56	8.23
WH132	4.25	5.25	1.75	0.50	3.00	-	-	-	0.81	15.25
WH132XHD	4.25	5.25	2.00	0.63	3.00	-	-	-	0.81	16.45

Specify left or right hand ordering

## Special Slotted A22 for Waferizer Chains



### Special Slotted A22 for Waferizer Chains

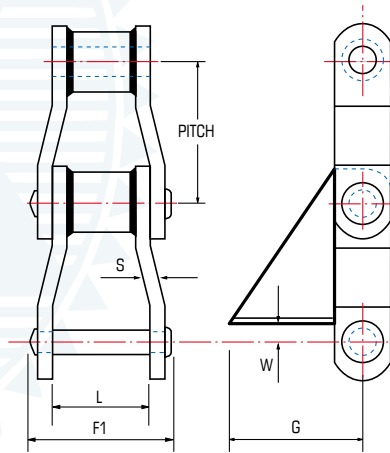
Chain Number	A	B	C	J	D	E	H	O	Q	Average Weight
	inches									
WH124	4.00	5.94	2.00	0.50	-	1.75	1.50	0.81	1.50	8.75
WH124XHD	4.13	6.06	2.00	0.50	-	1.75	2.00	0.81	1.50	15.55
WH106	4.00	5.94	2.00	0.50	-	3.00	1.50	0.81	1.50	8.20
WH106XHD	4.13	6.06	3.00	0.50	-	3.00	2.00	0.81	1.50	13.80
WH132	4.50	6.25	2.00	0.50	-	3.00	2.00	0.81	1.50	15.22
WH132XHD	4.63	6.38	2.50	0.50	-	3.00	2.00	0.81	1.25	16.42

All items to the left are also available fully heat treated, and/or IBR Induction Hardened Pins

# Welded Steel Chains | Mill Chains attachments

ISO DP6972 ANSI B29-16

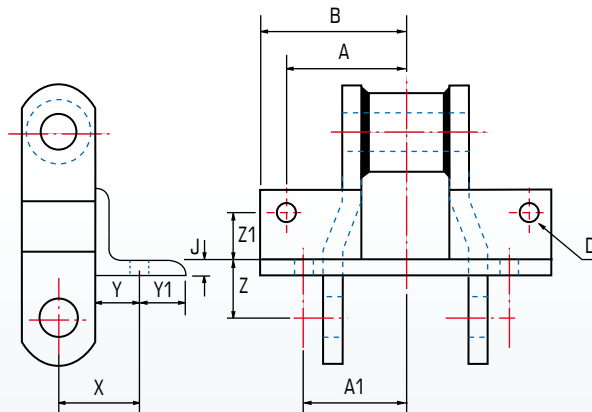
## S1 attachments



### S1 attachments

Chain Number	F1	L	S	G	W	Average Weight lbs/ft
	inches					
WH124	4.25	3.63	0.38	3.75	1.00	17.40
WH111	4.81	4.19	0.38	4.00	1.00	18.30
WH106	4.25	3.63	0.38	3.75	1.00	16.10
WH124XHD	4.88	4.13	0.50	3.75	1.28	26.00
WH132	6.25	5.28	0.50	5.00	1.28	18.00
WH150	6.25	5.28	0.50	5.50	1.28	20.00

## F4 attachments

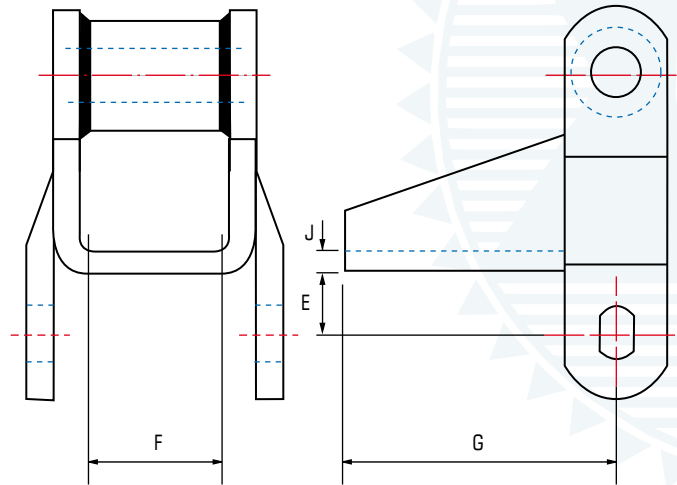


### F4 attachments

Chain Number	A	B	A1	D	J	X	Y	Y1	Z	Z1	Average Weight lbs/ft
	inches										
WH78	2.25	2.75	1.88	0.38	0.25	1.75	1.13	0.63	1.00	0.94	8.28
WH78XHD	2.25	2.75	1.88	0.38	0.25	1.75	1.13	0.63	1.00	0.94	9.88
WH82	2.50	2.94	2.06	0.38	0.25	1.81	1.19	0.81	1.25	1.13	8.88
WH82XHD	2.50	3.00	2.06	0.38	0.38	2.06	1.19	1.06	1.25	1.13	12.48
WH124	2.63	3.13	2.06	0.38	0.38	2.06	1.31	1.06	1.16	1.06	11.58



## H1 attachments

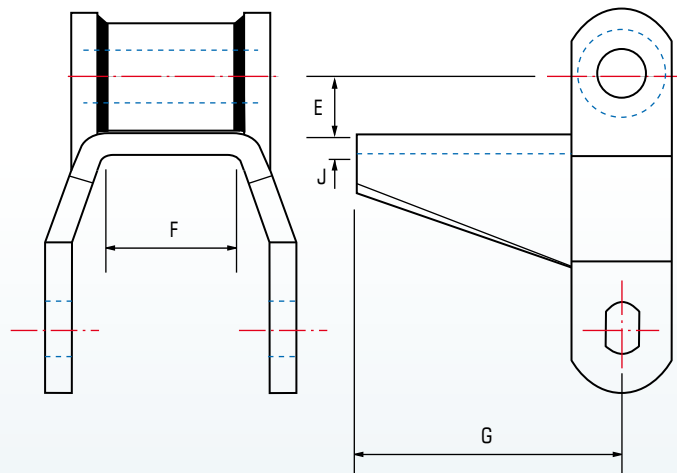


### H1 attachments

Chain Number	E	F	G	J	Average Weight
					lbs/ft
inches					
WH78	0.50	1.50	3.63	1.88	6.60
WH78XHD	0.50	1.50	3.63	1.88	9.50
WH82	0.63	1.75	3.63	1.88	8.90
WH82XHD	0.63	1.75	3.88	1.88	12.10

H1 also fits 81X

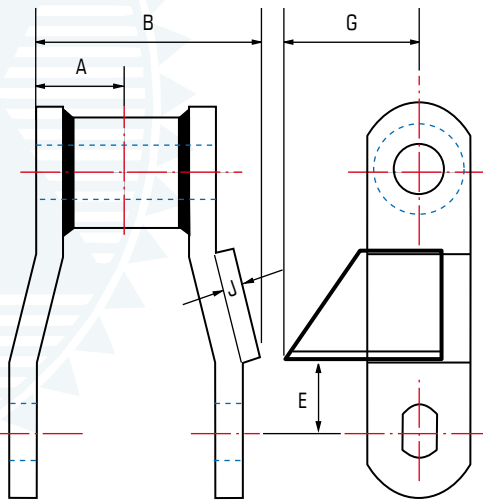
## H2 attachments



### H1 attachments

Chain Number	E	F	G	J	Average Weight
					lbs/ft
inches					
WH78	0.50	1.50	3.63	0.19	6.60
WH78XHD	0.50	1.50	3.63	0.19	9.50
WH82	0.63	1.75	3.63	0.19	8.90
WH82XHD	0.63	1.75	3.88	0.19	12.10

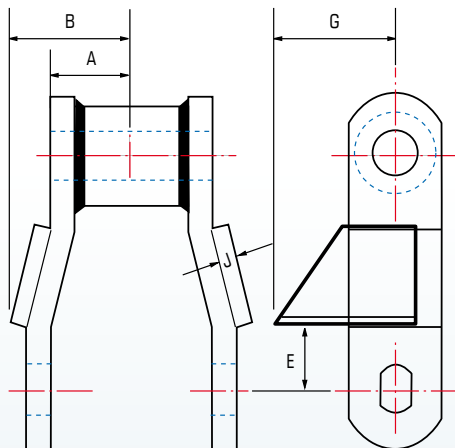
## R2 attachments



### R2 attachments

Chain Number	A	B	J	E	G	Weight lbs/ft
	inches					
WH78	1.50	2.00	0.25	1.00	1.56	4.40
WH78XHD	1.75	2.25	0.38	1.00	1.56	7.50
WH82	1.63	2.25	0.25	0.81	1.75	6.00
WH124	1.91	4.07	0.38	1.25	1.88	9.00

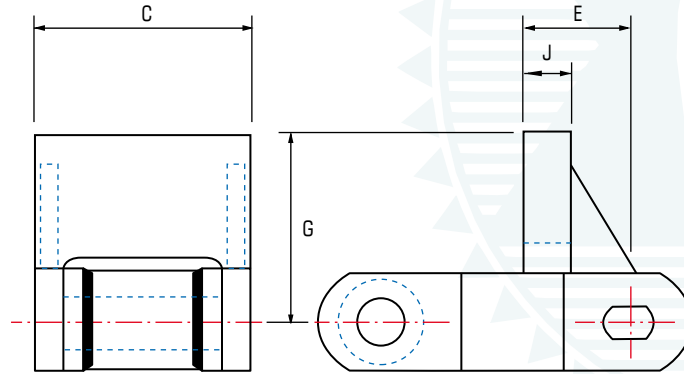
## RR2 attachments



### RR2 attachments

Chain Number	A	B	J	E	G	Weight lbs/ft
	inches					
WH78	1.50	2.00	0.25	1.00	1.56	4.8
WH78XHD	1.75	2.25	0.38	1.00	1.56	8.0
WH82	1.63	2.25	0.25	0.81	1.75	6.5
WH82XHD	1.94	2.38	0.38	0.81	2.06	8.5
WH124	2.13	2.75	0.38	1.50	1.88	9.3
WH132	3.08	4.41	0.50	1.50	2.50	16.0

## RF2 attachments

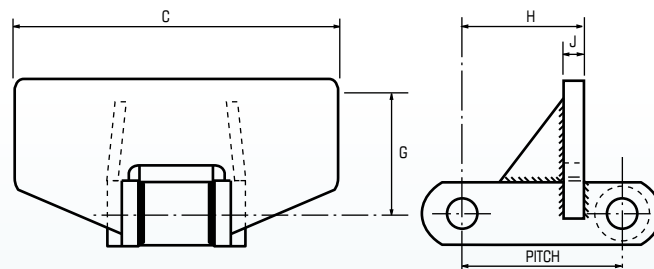


### RF2 attachments

Chain Number	G	E	J	C	Weight lbs/ft
	inches				
WH78	2.69	1.50	0.25	3.00	7.70
WH78XHD	2.69	1.50	0.38	3.00	10.70
WH82XHD	2.75	2.14	0.38	3.25	12.30
WH124	3.25	2.00	0.50	4.25	15.80
WH111	3.25	2.13	0.50	7.75	14.50
WH132	3.50	3.00	0.75	9.00	28.50

Also available for wide end forward operation

## RF12 attachments



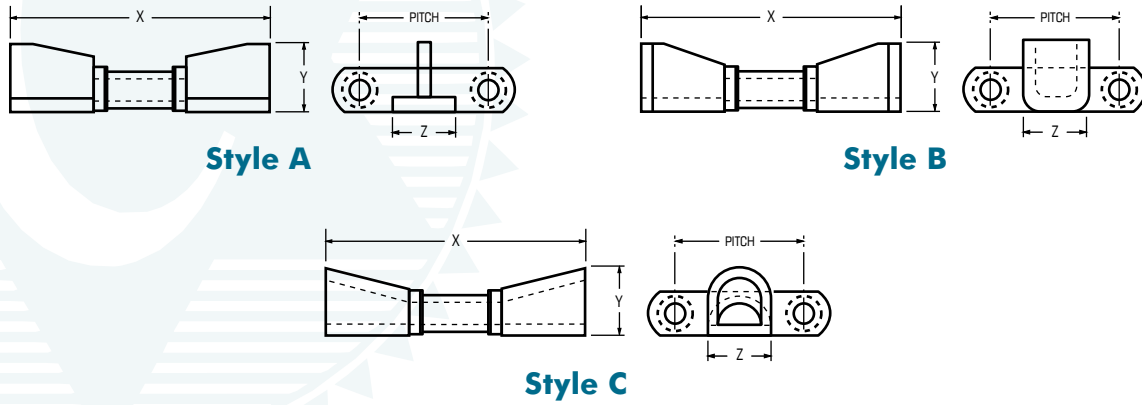
### RF12 attachments

Chain Number	G	H	J	C	Weight lbs/ft
	inches				
WH78	2.69	1.50	0.25	3.00	7.70
WH78XHD	2.69	1.50	0.38	3.00	10.70
WH82XHD	2.75	2.14	0.38	3.25	12.30
WH124	3.25	2.00	0.50	4.25	15.80
WH111	3.25	2.13	0.50	7.75	14.50
WH132	3.50	3.00	0.75	9.00	28.50

# Welded Steel Chains | Mill Chains attachments

ISO DP6972 ANSI B29-16

## Log Cradle For Single Strand Chains

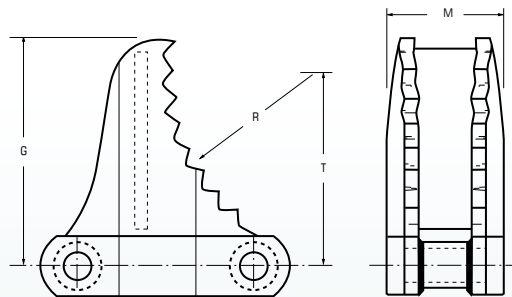


### Log Cradle For Single Strand Chains

Chain Number	Pitch	Style A			Style B			Style C			Special Style C		
		X	Y	Z	X	Y	Z	X	Y	Z	X	Y	Z
inches													
WH124	4.000	8.00	2.50	2.50	8.00	2.50	2.25	8.00	2.25	3.50	11.00	2.94	3.00
WH111	4.760	8.50	2.25	1.75	8.50	3.00	2.25	8.50	2.25	3.50	11.00	2.94	3.00
WH124XHD	4.050	8.50	3.00	2.50	8.50	3.00	2.50	8.50	3.00	3.00	11.00	3.75	3.00
WH106	6.000	8.00	2.25	3.00	8.00	2.25	2.25	8.00	2.25	3.50	11.63	2.94	3.50
WH132	6.050	11.00	3.00	3.00	11.00	3.00	3.25	11.00	3.00	3.50	13.00	3.50	3.50
WH132XHD	6.050	11.25	3.00	3.00	11.25	3.00	3.00	11.63	3.00	3.50	13.63	3.25	3.50

Note: Style "A" cradles could pose conveying problems – discuss with factory.

## Special Slasher attachments\*

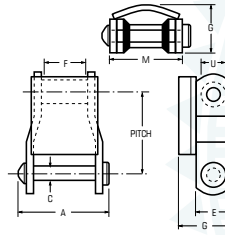


### Special Slasher attachments

Chain Number	G	R	T	M
	inches			
WH124	7.31	12.00	7.00	4.00
WH124XHD	7.31	12.00	7.00	4.25
WH106	8.25	6.00	6.75	3.88
WHC110	8.25	6.00	6.75	3.88
WH106XHD	9.00	6.38	7.00	4.08
WH132	7.31	6.00	7.00	5.50
WHC132	7.31	6.00	7.00	5.50

\*Available integral to sidebar or welded on

## Welded Steel Universal Top

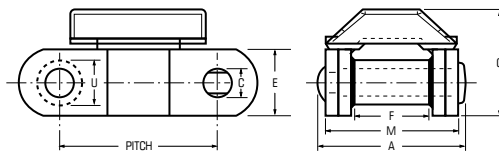


### Welded Steel Universal Top

Chain Number	Chain Pitch inches	Links pcs./ft	Average Weight lbs/ft	A	C	E	F	G*	M	U
				inches						
WH78 U	2.609	4.6	6.0	3.00	0.50	1.25	1.00	1.81	2.63	0.88
WH78 XHDU	2.636	4.6	10.4	3.45	0.56	1.25	1.00	1.90	2.81	1.00
WH82 U	3.075	3.9	8.0	3.50	0.56	1.25	1.13	2.00	3.00	1.00
WH82 XHDU	3.075	3.9	13.5	4.00	0.75	1.50	1.13	2.38	3.31	1.25
WH130/8U	4.000	3.0	4.8	3.00	0.50	1.25	1.00	1.81	2.63	0.88
WH124 U	4.000	3.0	13.0	4.25	0.75	1.50	1.50	2.50	3.63	1.25
WH124 XHDU	4.063	3.0	19.8	4.63	1.00	2.00	1.50	3.25	4.06	1.63

\* Nominal Dimension

## Welded Steel Chains with U.H.M.W. Cap

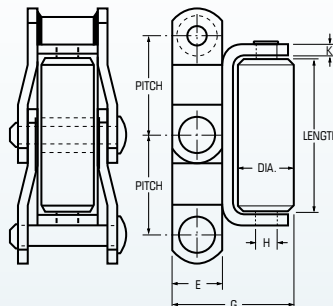


### Welded Steel Chains with U.H.M.W. Cap

Chain Number	Chain Pitch inches	Links pcs./ft	Average Weight lbs/ft	A	C	E	F	G*	M	U
				inches						
WH78 UP	2.609	4.6	5.4	3.00	0.50	1.25	1.00	1.94	2.63	0.88
81X UP	2.609	4.6	3.4	2.50	0.44	1.13	0.88	1.88	1.63	0.88

\* Nominal Dimension

## Steel Roll Top Chains with Nylon Rollers



### Steel Roll Top Chains with Nylon Rollers

Chain Number	Chain Pitch inches	Links pcs./ft	Average Weight lbs/ft	Roller Length	Roller Dia.	Side Bar Width	Overall Height	Cradle Material	Roller Rivet Dia.	
						E	G	K	H	
							inches			
WR-78RTN	2.609	4.60	7.85	4.00	1.25	1.25	3.13	0.25	0.50	

Standard rolltop chain supplied with solid nylon roller. WRC 78 (combination chain) styles also available.



# Welded Steel Chains | Drag Chains

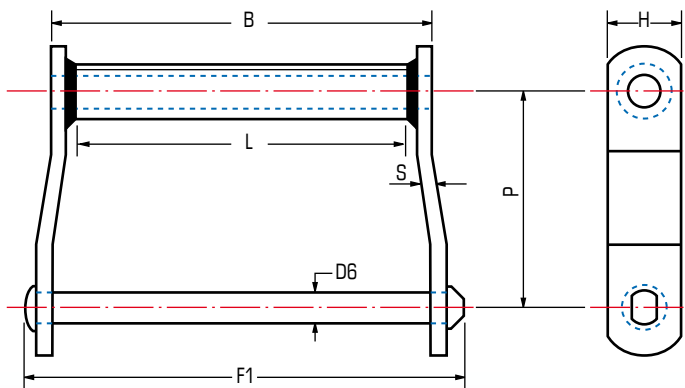
ISO DP6972 ANSI B29-18



## Welded Steel Drag Chains

JOHN KING wide series WDH chain are intended to be used in applications where joint and barrel diameter wear are an issue.

Features include original formed barrel design for complete bearing pin to barrel contact. As with narrow series, many material and heat treatment configurations are available. Special attention is paid to pitch control to ensure that, in multiple strand applications, such as chipper infeeds or live bottom bins there is accurate matching between the strands.



### JK Welded Steel Drag Chains

Chain Number	P	Breaking Load	Average Weight	Over-All Width	Between Sidebars	Sidebars		Rivet. Diameter	Length Of Bearing
						Thickness	Height		
						S	H		
	inches	lbs	lbs/ft	F1	L	inches		D6	B
WDH102	5.00	55,000	11.80	9.25	6.38	0.38	1.50	0.75	7.75
WDH104	6.00	55,000	8.50	6.75	4.13	0.38	1.50	0.75	5.38
WDH110	6.00	55,000	12.00	11.75	9.00	0.38	1.50	0.75	10.25
WDH112	8.00	55,000	10.00	11.75	9.00	0.38	1.50	0.75	10.25
WDH116	8.00	59,000	18.50	15.50	13.00	0.38	1.75	0.75	14.13
WDH118	8.00	79,000	21.00	16.63	13.25	0.50	2.00	0.88	14.88
WDH120	6.00	79,000	20.00	12.00	8.75	0.50	2.00	0.88	10.25
WDH480	8.00	79,000	18.00	14.50	11.20	0.50	2.00	0.88	12.75
WDH580	8.00	108,000	19.40	14.63	11.20	0.50	2.00	1.00	12.10
WDH680	8.00	108,000	21.00	15.33	11.20	0.63	2.00	1.00	13.00



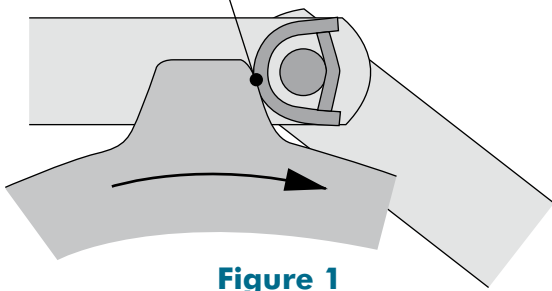
## Reverse Barrel Wide Series Drag Chains

The standard wide series welded steel drag chain is designed to travel narrow end forward. In considering the offset sidebar style this direction of travel will create additional friction between the gearing face of the barrel and the tooth flank of the driving sprocket (fig.1). This condition is accentuated on short centered conveyors where the frequency of barrel and sprocket interaction is increased.

A simple solution was seen in the introduction of the RB series where the barrel is reversed to allow the chain to run open end forward. In this event instead of the articulation occurring between barrel and tooth flank it occurs inside the internal area where the pin will rotate within the barrel (fig. 2). This is preferable since the components are specifically suited to contact between two hardened bearing surfaces along the full width of the chain.

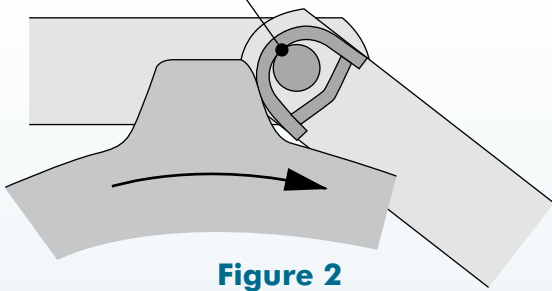
We therefore recommend RB series when centres are short and loads heavy where the typical failure mode is breaking chain barrels or welds.

Articulation is Between Chain Barrel and Sprocket Tooth

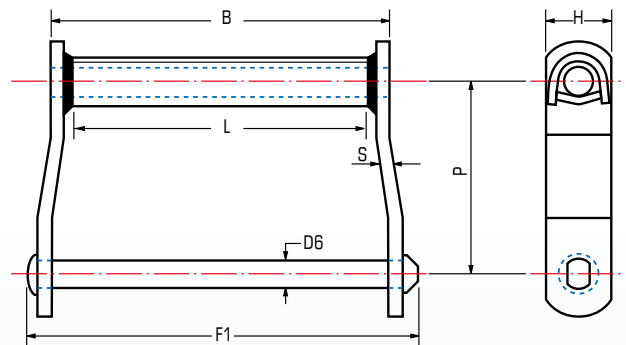


**Figure 1**

Articulation is Between Pin and Barrel



**Figure 2**

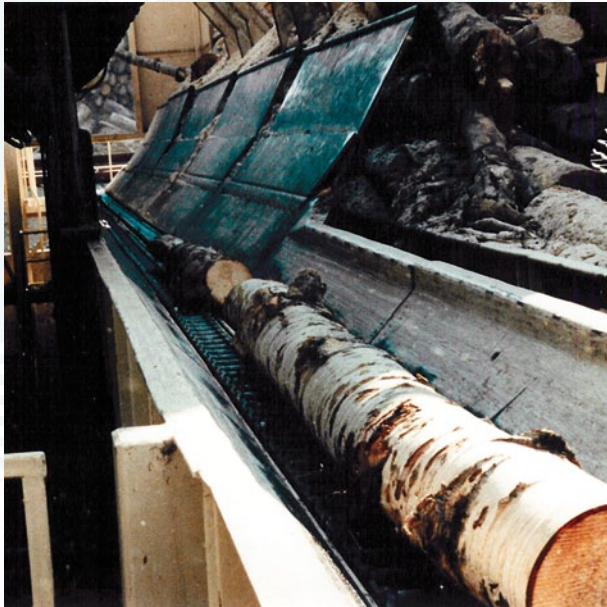


### JK Welded Steel Drag Chains

Chain Number	P	Breaking Load	Average Weight	Over-All Width	Between Sidebars	Sidebars		Rivet. Diameter	Length Of Bearing
						Thickness	Height		
	inches	lbs	lbs/ft	F1	L	S	H	D6	B
inches									
WDH110	6.13	55,000	12.00	11.75	9.00	0.38	1.50	0.75	10.25
WDH116	8.12	59,000	18.50	15.50	13.00	0.38	1.75	0.75	14.13
WDH480	8.16	79,000	18.00	14.50	11.20	0.50	2.00	0.88	12.75

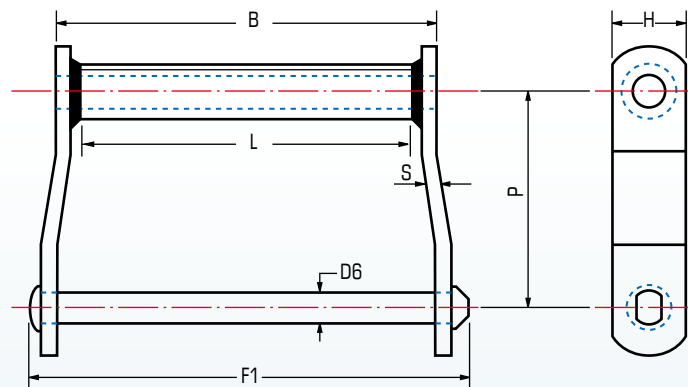
# Welded Steel Chains | Drag Chains

ISO DP6972 ANSI B29-18



## Heavy Duty Cobra Drag Chains

John King Extra Heavy Duty Drag Link is available in the Cobra range. The King Cobra follows the standard series but includes increased plate thickness and pin diameter. This chain may be selected where the chain is subject to higher loads or adverse operating conditions of high impact.



### JK Welded Steel Drag Extra Heavy Duty (XHD) Chains

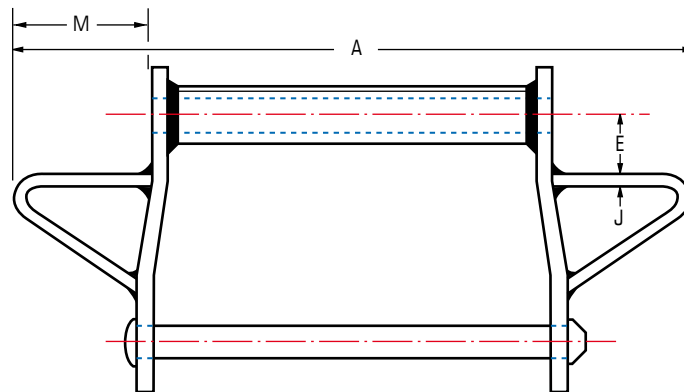
Chain Number	P	Breaking Load	Average Weight	Over-All Width	Between Sidebars	Sidebars		Rivet Diameter	Length Of Bearing
						Thickness	Height		
	inches	lbs	lbs/ft	F1	L	S	H	D6	B
	inches								
WDH120XHD	6.00	140,000	22.5	12.75	8.75	0.63	2.00	1.00	10.50
WDH118XHD	8.00	140,000	22.5	17.38	11.00	0.63	2.00	1.00	15.13
WDH122XHD	8.00	140,000	19.5	12.75	8.75	0.63	2.00	1.00	10.50
WDH480XHD	8.00	140,000	21.0	15.25	11.00	0.63	2.00	1.00	13.00





## Wing attachments

The trough width can be increased by the addition of wing attachments. This can be a cost effective way of improving material throughput particularly in transporting low density material. The recommended maximum flight widths are detailed. Anything outside this range should be referred to JOHN KING Engineering.

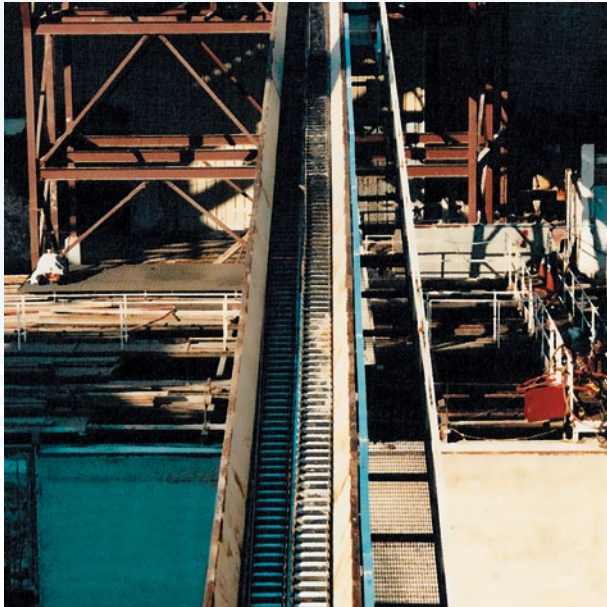


### JK Drag Chains With Wing attachments

Chain Number	A	E	J	M
	inches			
WDH102	14.50	1.50	0.38	3.25
WDH104	12.00	2.25	0.38	3.38
WDH110	17.00	2.25	0.38	3.38
WDH112	17.00	2.25	0.38	3.38
WDH116	22.00	2.50	0.38	3.94
WDH118	22.00	2.50	0.50	3.56
WDH120	17.00	2.50	0.50	3.38
WDH480	22.00	2.50	0.50	4.63
WDH120XHD	17.25	2.50	0.50	3.25
WDH118XHD	22.25	2.50	0.50	3.44
WDH480XHD	22.25	2.50	0.50	4.50

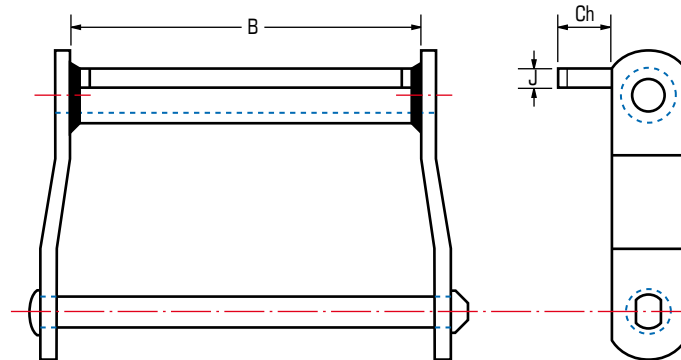
# Welded Steel Chains | Drag Chains attachments

ISO DP6972 ANSI B29-18



## Attachments C-1/2, C-1, C-3, C-4

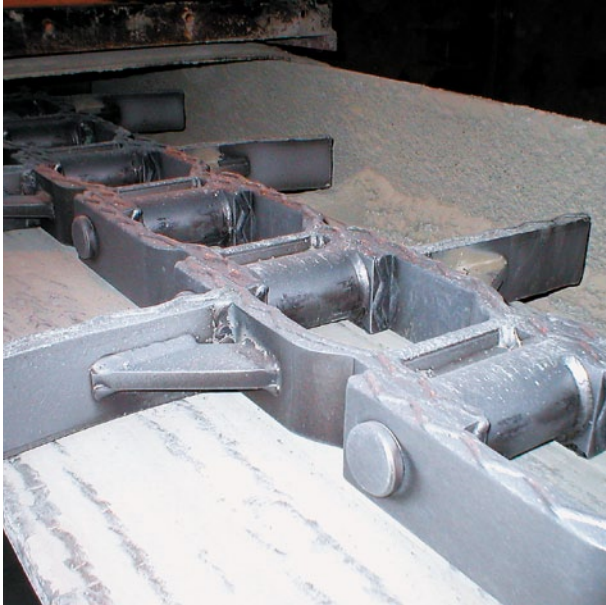
C style attachments. C style attachments are an “upstand” addition to the standard WDH series. C-1/2 attachments are fixed to the front of the barrel and do not extend above the sidebar height. C-1, C3 and C4 are fixed to the top of the barrel. The purpose in all cases is to improve material penetration; reduce fall back of material on inclines and generally improve throughput.



### JK Welded Steel Drag Chains with attachments

Chain Number	C-1/2			C-1			C-3			C-4		
	B	J	Ch	B	J	Ch	B	J	Ch	B	J	Ch
inches												
WDH102	6.75	0.38	1.50	6.75	0.38	1.50	6.75	0.38	1.75	6.75	0.38	3.00
WDH104	4.50	0.38	1.50	4.50	0.38	1.50	4.50	0.38	1.75	6.75	0.38	3.00
WDH110	9.25	0.38	1.50	9.25	0.38	1.50	9.25	0.38	1.75	6.75	0.38	3.00
WDH116	13.00	0.38	1.75	13.00	0.38	1.75	13.00	0.38	1.75	6.75	0.38	4.00
WDH118	13.50	0.50	2.00	13.50	0.50	1.75	13.50	0.38	2.00	6.75	0.50	4.00
WDH120	9.00	0.50	2.00	9.00	0.50	1.75	9.00	0.38	2.00	6.75	0.50	4.00
WDH122	9.00	0.50	2.00	9.00	0.50	1.75	9.00	0.38	2.00	6.75	0.50	4.00
WDH480	11.50	0.50	2.00	11.50	0.50	1.75	11.50	0.38	2.00	6.75	0.50	4.00

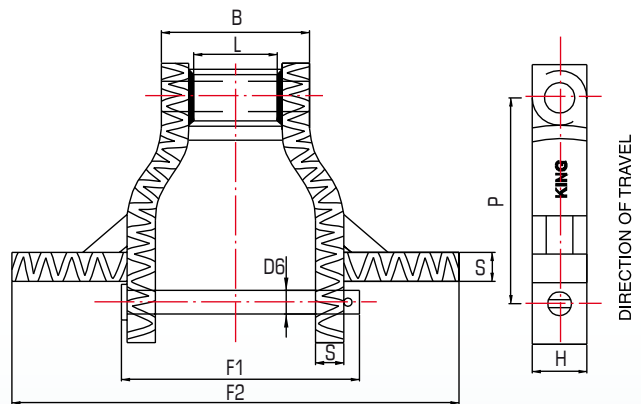




## Crusader Heavy Duty Steel Drag Chains (WHX)

This welded steel option can be considered in place of cast S series drags and is ideal where conditions of high abrasion and heat prevail.

- Fabricated construction with material options in flat and round section for each component allows the construction of CRUSADER to have greater consistency and integrity.
- The crusader series employs optimum materials and heat treatment conditions to ensure good resistance to shock loading and extended service life. Square edged wing and link plate section creates increased conveying efficiency and transport of a deeper bed of material.
- Hard face welding on all sliding and wear surfaces is standard. A typical weld surface of 60 HRC and with heavy weld bead gives CRUSADER excellent sliding wear resistance in cold and hot clinker applications.



### Crusader Heavy Duty Welded Steel Drag Chains

Chain Number	Pitch	Breaking Load	Average Weight	Over-All Pin & Cotter	Width Over-All	Between Sidebars	Sidebars		Rivets Diameter	Length of Bearing			
	P			F1	F2*		L	Thickness			Height	D6	B
	inches			lbs	lbs/ft		inches	inches			inches	inches	inches
WHX5157	6.05	175,000	25.31	6.94	8 to 14	2.75	0.63	2.50	1.13	4.63			
WHX6067	9.00	225,000	30.43	8.19	10 to 26	3.63	0.75	2.50	1.25	5.50			
WHX5121	9.00	275,000	40.47	9.75	10 to 30	3.63	1.13	2.50	1.25	6.31			
WHX6121	9.00	275,000	40.47	9.75	10 to 30	3.63	1.13	2.50	1.25	6.31			

\* In increments of 2".

Note: Breaking loads based on standard specification. For elevated temperatures this specification may change and with it the breaking load. Please consult John King technical.



# JOHN KING



**John King Chains Limited**  
New Climax Works,  
Lancaster Business Park,  
Sherburn-in-Elmet LS25 6NS UK  
Tel: (44) 1977 681 910  
Fax: (44) 1977 681 899  
Email: [general@johnkingchains.co.uk](mailto:general@johnkingchains.co.uk)

**John King USA Inc.**  
200 Catherine Street, Unit 7, Box 8,  
East Peoria, USE IL 61611  
Tel: (1) 309 698 9250  
Fax: (1) 309 698 9529  
Email: [cr@johnking-chain.com](mailto:cr@johnking-chain.com)

**John King Chains (SA) (PTY) Ltd.**  
No. 17 N12 Airport Industrial Park,  
Dr. Vosloo Road, Barletts, Boksburg,  
Johannesburg  
Tel: (27) 11 894 3570  
Fax: (27) 11 894 3501  
Email: [sales@jkc.co.za](mailto:sales@jkc.co.za)

**Cadenas John King Ltda.**  
Panamericana 5 Sur Km. 34  
Parcela 13 – Lote C  
Buin – Santiago, Chile  
Fonos: (56) 2517 7313  
Email: [manuel@johnkingchains.com](mailto:manuel@johnkingchains.com)

**John King Chains  
(Central Europe)**  
ul. Grunwaldzka 182  
85-401 Bydgoszcz, Poland  
Tel/Fax: (48) 52 349 08 97  
Mobile (48) 600 871 077  
Email: [aw@johnkingchains.com](mailto:aw@johnkingchains.com)



REG NO: FM77342

[www.johnkingchains.com](http://www.johnkingchains.com)