



PTH 1000/1000 M



pezzolato

Drum chippers **PTH** Series

*Whatever wood,
the best chips*

GREENLINE

**PTH 1000/1000
PTH 1200/1000**





PTH 1200/1000 M

PTH 1000/1000
PTH 1200/1000

Heavy-duty machines within Pezzolato drum chippers to chip big diameter logs, their drum diameter measures 1000 mm.

The feeding mouth and the drum width distinguish the two models.

Able to produce 130 up to 180 m³ chips per hour, they guarantee high throughput.

Powered by tractor Power Take Off or provided with autonomous diesel engine or electric motor.

Thanks to the closed drum and the two blades, as large as the whole drum axis, they produce high quality

chips, whatever wood is cut, considerably reducing fuel consumption. The sharp cut through the blades and the drum's inertia reduce the machine's efforts and stress, thus confirming the well-known solidity of Pezzolato drum chippers.

The wear parts of all machines are simple to replace in short maintenance times and cheap.

The electronic controller suggests any ordinary and extraordinary maintenance operations to be performed according to the manufacturer's maintenance plan.



Big feeding hopper



Compact for transportation



PTH 1200/1000 M

PEZZOLATO, A 360° COMPANY

REALIZATION

A continuous R&D program supports Pezzolato machines' development and manufacturing. Such activities are totally performed in house; own specialized personnel follows any single step up to the delivery of any machines.

COMPONENTS

All hydraulic, electric and electronic components mounted on Pezzolato chippers are supplied exclusively by prime-quality European manufacturers.

ASSISTANCE

Technical assistance is provided quickly and performed by own personnel. Specialized Pezzolato technicians are always available to intervene directly or to support local authorized dealers and service facilities.

SPARE PARTS

Thanks to its large stock, Pezzolato is able to send and deliver any spare parts at customers' premises all over the world, within 24/48 hours.

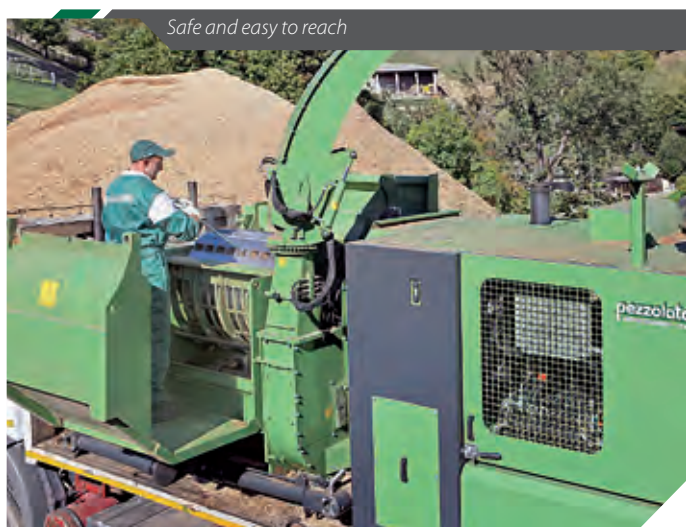

Safe and easy to reach



Electronic controller

EXTRAS AND CONFIGURATIONS

Pezzolato SpA cares for its customers needs and listens carefully to the machines' end-users, further being a flexible and versatile company. Pezzolato machines can be customized through a series of extras, i.e.:

- ▼ **Special drum** to produce **extra size chips**: it improves production capacity 15% and reduces fuel consumption 16%
- ▼ **Recovering collecting screws**, under the feeding roller, to keep the working area clean
- ▼ **Sieving grids** with different sizes, easy to replace
- ▼ **Collapsible counter-blade** secured with shear bolts
- ▼ Hydraulically folding **hopper extension**, to easily introduce certain types of wood
- ▼ **Hydraulically bending hopper**, to chip very long wood
- ▼ **Radio remote control** to manage the chipper's main activities at a distance
- ▼ **Tracks** to drive the machine in impassable paths
- ▼ **Reversible fans for radiator cleaning**, to clean the motor radiator and save fuel
- ▼ **Rotating discharge belt**, to obtain better quality chips
- ▼ **C-shaped Woodsplitter** with or without chain saw
- ▼ **Integrated container**, hydraulic pivoting, to collect chips wherever no means of transportation can access
- ▼ **Hydraulic traction**, to easily move the machine in impervious paths
- ▼ **Hook-lift system**
- ▼ **Telescopic legs** enable transportation of the chipping unit on several vehicles
- ▼ **Low- or high-speed towing trailer**, with air or hydraulic brakes
- ▼ PTO and Diesel Engine powered chippers are available to **mount on Forestry Trailers and self powered Forwarders**
- ▼ **Drive-line hopper**, to feed the machine with voluminous material
- ▼ **Rotating thrust block (fifth wheel)**, to feed the machine right or left hand
- ▼ **3 point hitch attachment**, to compact the machine and work in narrow places
- ▼ **Forestry cranes**, with or without cabin, in customized configuration
- ▼ **Sliding frame**, to expand the reach of the crane and speed up wood introduction
- ▼ **LCD color Display** and inspection camera



Sieving grid and collecting screws



Woodsplitter and chain saw



Forestry crane and sliding frame



Bending hopper



Discharge belt



Extra size chips



Telescopic legs



Hook-lift system



80 km/h towing trailer

"PEZZOLATO CHIPS" ARE CERTIFIED



Chips size and features as produced by Pezzolato drum chippers has been analysed and verified by CNR IVALSA (National Research Council of Italy. Trees and Timber Institute).



PEZZOLATO CUTTING TECHNOLOGY GUARANTEES HIGH QUALITY CHIPS

Pezzolato cutting technology consists in a closed drum provided with blades as large as the whole drum axis, a counter blade and an interchangeable sieving grid.

Such system, that has traditionally been mounted on industrial stationary chippers, guarantees the production of high quality chips; wood is in fact forced against the blades and is thus transformed into homogeneous chips, which pass through the sieving grid immediately after cutting. The closed drum also helps keeping the chips cutting length fixed and constant.

TWO BLADES, MAKE PEZZOLATO

Pezzolato drums can be provided with two different blades:

Standard: i.e. the traditional blade that has always been mounted on Pezzolato drum chippers. It allows setting different cutting lengths and is easy to replace, it can be sharpened up to 20 times, it is applicable to a special drum for producing extra size chips.

Quick&Smart: provided with a revolutionary fixing system, it is fixed directly to the drum, is easy to handle and quick to replace, it costs 30% less than a traditional blade (to buy and to maintain), it can be sharpened up to 3 times.

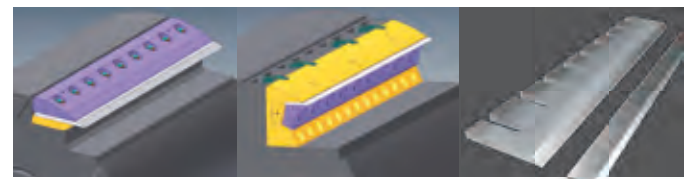
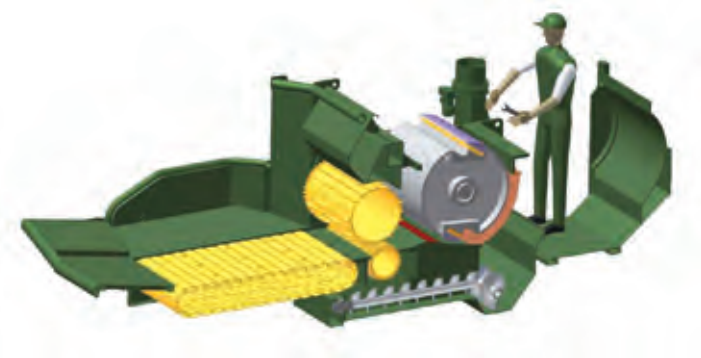

STANDARD BLADE

QUICK&SMART BLADE

PEZZOLATO COLLAPSIBLE COUNTER-BLADE SECURED WITH SHEAR BOLTS

The chipper can be supplied with a collapsible counter-blade mounted on a running slide and secured with adjusted shear bolts. Whenever a hard body is accidentally entered into the chipper, the bolts are sheared and the counter-blade falls down, so that the foreign body exits before causing damages.

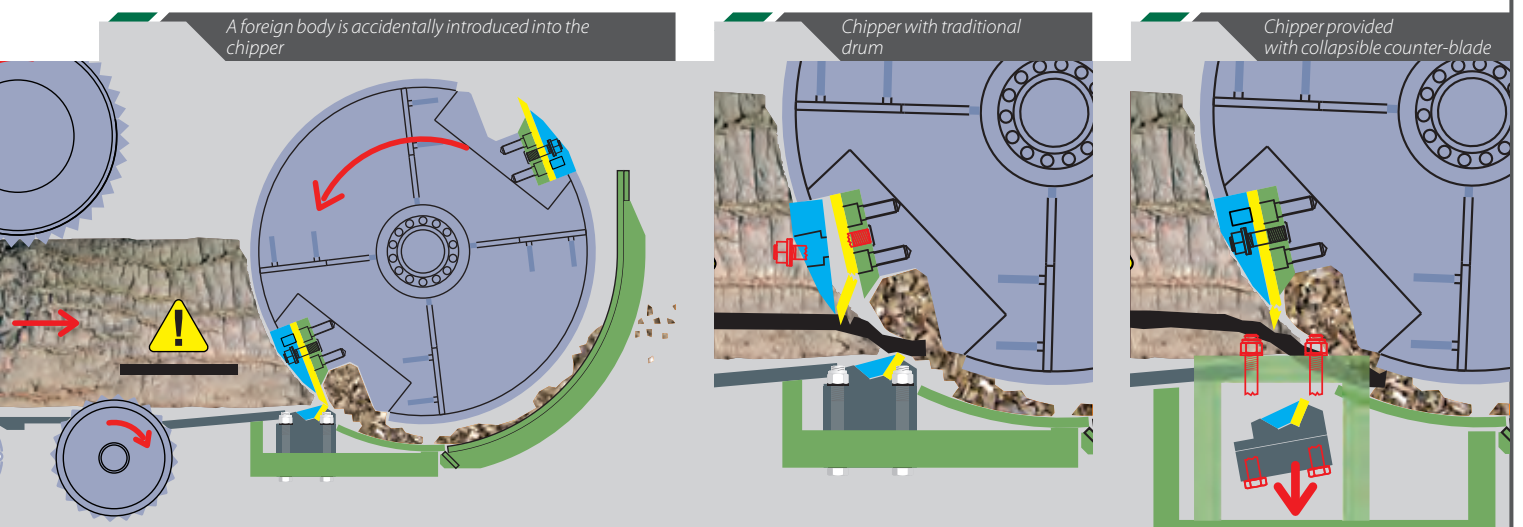

TECHNICAL FEATURES		PTH 1000/1000	PTH 1200/1000
Minimum tractor power	Hp/kW	200/147	200/147
Maximum tractor power	Hp/kW	400/294	400/294
Diesel motor power	Hp/kW	510/375 - 800/588	510/375 - 800/588
Electric engine power	kW	315	315
Maximum chipping diameter (soft wood)	mm	700	700
Maximum chipping diameter (hard wood)	mm	550	550
Blades	n°	2	2
Hourly throughput	m³/h	130-150	150-180
Drum diameter	mm	1000	1000
Drum width	mm	1000	1200
Feeding chain width	mm	1000	1200
Feeding chain length	mm	1440	1440
Hopper width*	mm	1780	2190
Lower rollers	n°	2	2
Weight motor machine (std model)*	kg	16500	18000
Weight PTO machine (std model)*	kg	14500	16000

*Such data may vary according to the machine settings

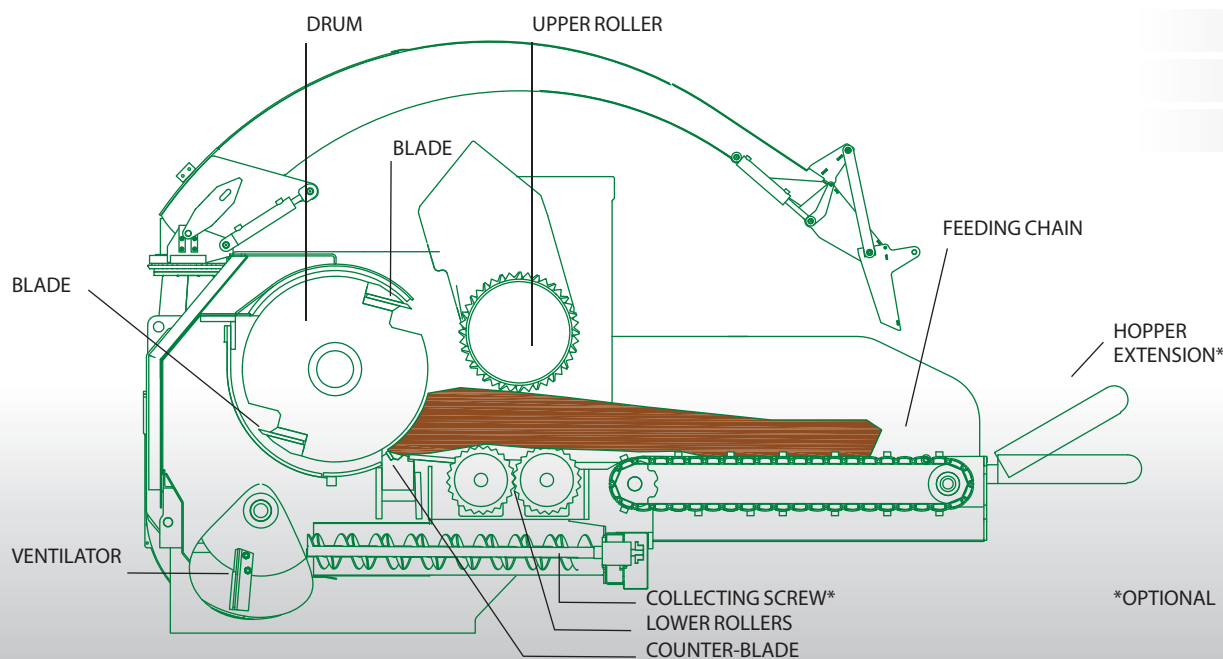

Dealer



Pezzolato Officine Costruzioni Meccaniche SpA
 Via Provinciale Revello, 89 | 12030 Envie (CN) ITALIA
 Tel. +39 0175 278077 | Fax +39 0175 278421 | info@pezzolato.it

www.pezzolato.it