



Firewood Disc Processors with Integrated Wood Splitter

*Professional machines
to process firewood*

REDLINE

TLC 1000 • 1100 • 1200 • 1300 • 1500
TL 1000



TLC 1000

TLC Series

Series TLC machines, i.e. compact firewood processors, have been produced over the last 18 years and changed the firewood preparation all over the world with attention to safe processing.

Their main features are the following:

- They are operated by one operator only
- They can work manually or totally in automatic
- They can be driven by electric motor / tractor PTO

From the control panel the operator can choose, manually or in automatic, the cutting length, the splitting grid positioning, the rests shape; he also can start the log loader. By automatic cut, the

splitting grid moves automatically according to the wood diameter to be split.

Furthermore, in any TLC machine the splitting grid can be excluded to process wood bundles that do not need to be split.

The particular shape of the machine makes it easy for the operator to see and control any stage of the working cycle with no efforts.

All TLC machines are equipped with an hydraulic "load sensing" control system, which improves its efficiency, reduces energy consumption and makes the machine life cycle longer, by improving its working processes.



Only-cut configuration: to process bundles that do not need to be split



Cut-and-split configuration: to process one single log at a time



PEZZOLATO, A 360° COMPANY

REALIZATION

A continuous R&D program supports Pezzolato machines' development and manufacturing. Such activities are totally performed in house; own specialized personnel follows any single step up to the delivery of any machines.

COMPONENTS

All hydraulic, electric and electronic components mounted on Pezzolato machines are supplied exclusively by prime-quality European manufacturers.

ASSISTANCE

Technical assistance is provided quickly and performed by own personnel. Specialized Pezzolato technicians are always available to intervene directly or to support local authorized dealers and service facilities.

SPARE PARTS

Thanks to its large stock, Pezzolato is able to send and deliver any spare parts at customers' premises all over the world, within 24/48 hours.

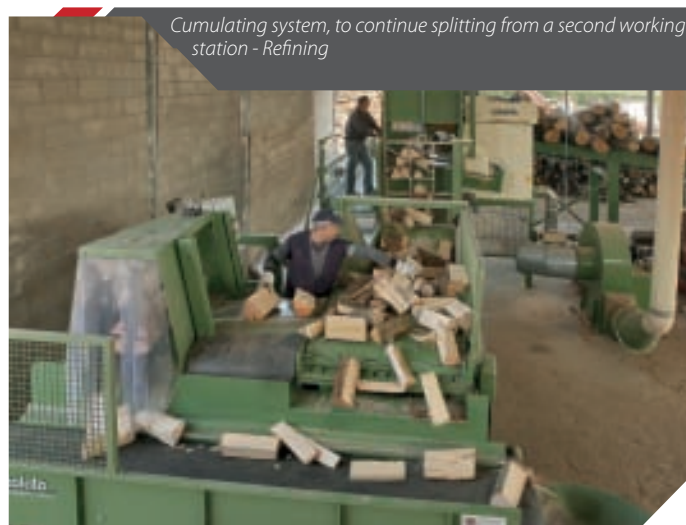

EXTRAS AND CONFIGURATIONS

Pezzolato SpA cares for its customers' needs and listens carefully to the machines' end-users, further being a flexible and versatile company. Pezzolato machines can be customized through a series of extras, i.e.:

- ▼ **Loading dumpers**, to process big size logs. Shock absorbers.
- ▼ **Lifting wood pusher**, to load a new piece of wood in the feeding throat while still cutting, speed-up the working cycle and improve the machine production capacity
- ▼ **Hydraulic log turner**, to manage unregular shaped logs.
- ▼ **Chain wood clamp**, to block wood while cutting, also different diameter logs.
- ▼ **Multifolds grid**, further to the 2+4+6 folds grid.
- ▼ **Control panel / computer**. Tested electronic control systems guarantee fast working cycles, optimize the machine production capacity and efforts.
- ▼ **Cleaning rollers** on conveyors, to separate barks, sawdust and wood blocks.
- ▼ **Integrated conveyor** to load processed wood, hydraulically adjustable, attached to the machine.
- ▼ **Raised plant**, for easy maintenance and cleaning.
- ▼ **6 up to 15 m discharge conveyors**, height hydraulically adjustable, manually or hydraulically orientable.
- ▼ **Pallet wood packer**, to pack cut and split wood for pallet transportation and stock.
- ▼ **Log loader**. The best loader is provided according to the wood to be processed.
- ▼ **C-shaped log separating system**: by pushing arms, steps with alternated movement, according to the logs to be processed.
- ▼ **Tailor made configurations**, to install plants in narrow places.



Loading dumpers



Lifting wood pusher



Log turner

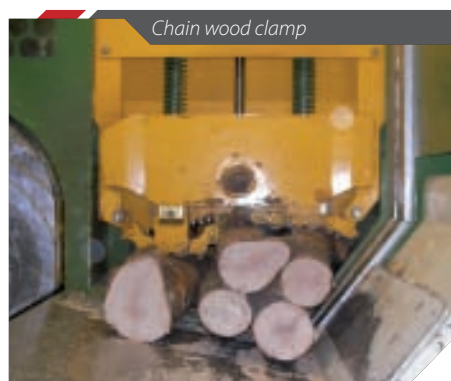

Chain wood clamp



Cleaning rollers



Integrated conveyor



Multifolds grid



Control panel / computer



C-shaped log separating system



TL 1000

TL 1000

Ideal machine to cut and split logs up to 380 mm diameter and to cut bundles that do not need to be split. Compact machine with solid structure. Powerful 20 ton wood splitter. Hydraulic guillotine wood clamp

Optional

- 2/4, 2/6, 2/8 or 2/4-6/10 folds splitting wedge
- 3 or 4 m unloading conveyor with PVC belt
- 4 m unloading conveyor with hydraulic folding device
- Non homologated low-speed towing trailer
- Driving by tractor PTO, 18,5 kW electric motor, combined system (PTO + 18,5 kW electric motor)



Cut-and-split configuration: to process one single log at a time



Only-cut configuration: to process bundles that do not need to be split

TECHNICAL FEATURES		TLC 1000	TLC 1100	TLC 1200	TLC 1300	TLC 1500	TL 1000
Disc (with hard metal tipped teeth) diameter	mm	1000	1100	1200	1300	1500	1000
Max log diameter	mm	400	450	480	520	600	380
Splitting force	Ton	20 - 27	20 - 27	27 - 32 - 45	32 - 45	70	20
Minimum tractor power *	Hp	70	70	90	90	120	60
Electric motor power	kW	22 - 30	22 - 30	30 - 37 - 45	37 - 45	55 - 75	18,5
Hydraulic splitting grid/ wedge	folds	Upon request	Upon request	Upon request	Upon request	Upon request	2/4 - 2/6 - 2/8 2/4-6/10
Weight*	kg	5500	6000	7000	8000	9500	2200
Cutting length	cm	20 - 65	20 - 65	20 - 65	20 - 65	20 - 65	20 - 50

*The above mentioned data may vary according to the machine setting

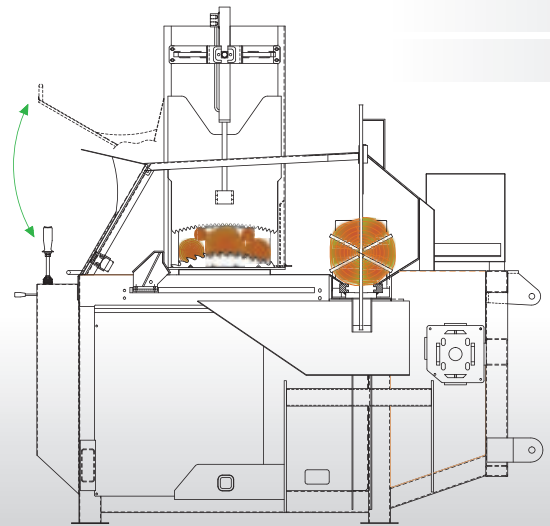
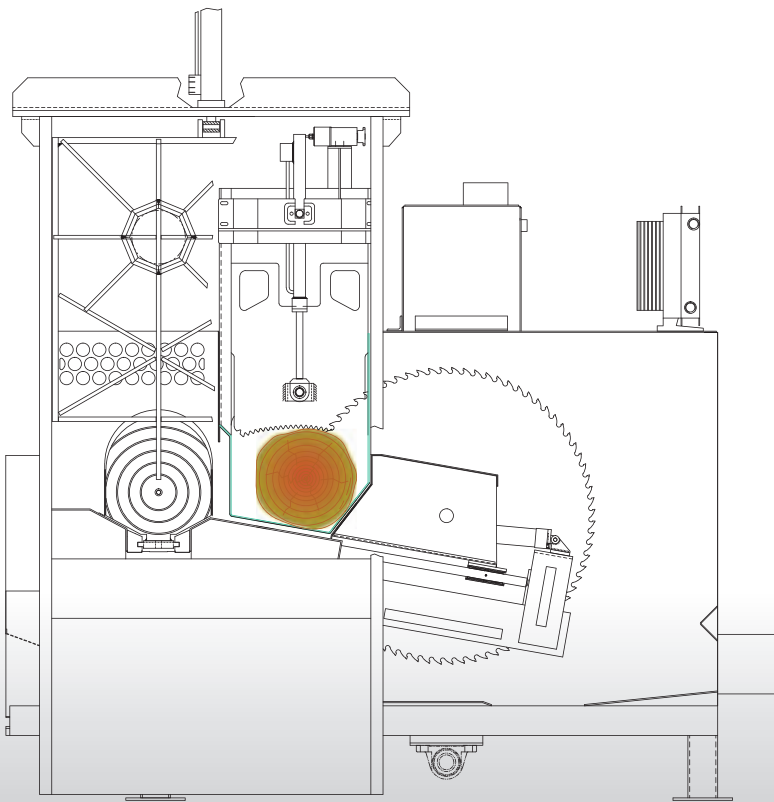

Dealer

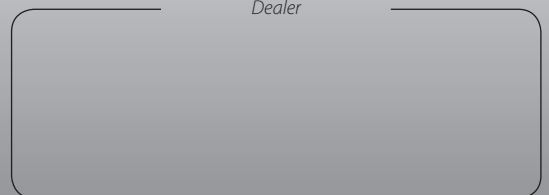

Pezzolato Officine Costruzioni Meccaniche SpA
 Via Provinciale Revello, 89 | 12030 Envie (CN) ITALIA
 Tel. +39 0175 278077 | Fax +39 0175 278421 | info@pezzolato.it

www.pezzolato.it