

Tradition. Ambition. Vision.

Find out more about the future at randek.com

BUTTERFLY TABLE BS20

RANDEK 

BUILDING THE FUTURE

FLEXIBLE AND EFFICIENT SYSTEM FOR PREFABRICATED HOUSE MANUFACTURING

RANDEK BUTTERFLY TABLE BS20 IS A FLEXIBLE AND EFFECTIVE SYSTEM FOR PRODUCTION OF ALMOST ANY TYPE OF BUILDING ELEMENT SUCH AS: WALLS, FLOORS, INNER/OUTER ROOF AND GABLE ENDS.

BS20 is developed for production of prefabricated building elements and is a popular machine for start-up companies but also larger producers use the system in their entire production.

BS20 tables are standard equipped with functions to ensure a high-quality and effective production. Beyond this there are many additional functions available, developed in close contact with our successful customers around the world.

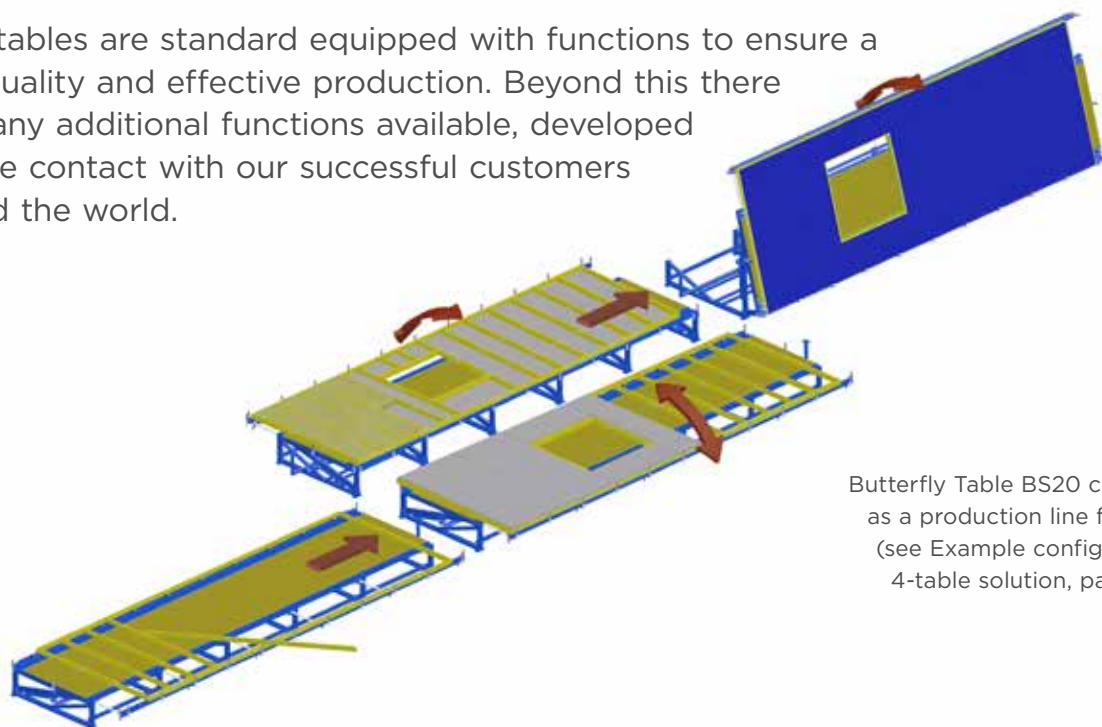

Butterfly Table BS20 configured as a production line for walls (see Example configuration 4-table solution, page 8)

- Flexible system
- Length of table 6.0, 7.5, 9.0 or 12.0 m
- Width adjustment (wall height) between 2250 – 3100 mm (option 100 – 3650 mm)
- The system can be used as a separate table or configured as a complete production line
- Pneumatic or hydraulic squaring function ensures a high quality and effective production
- Hydraulic turning function for safe and effective turning of building elements

UPRAISE TABLE BS10U

Upraise Table BS10U is the starting point for most BS20 system. The table is equipped with pneumatic squaring function and width adjustment function. The table is covered with plywood and removable support pins for squaring of the building elements are placed on both sides of the table.

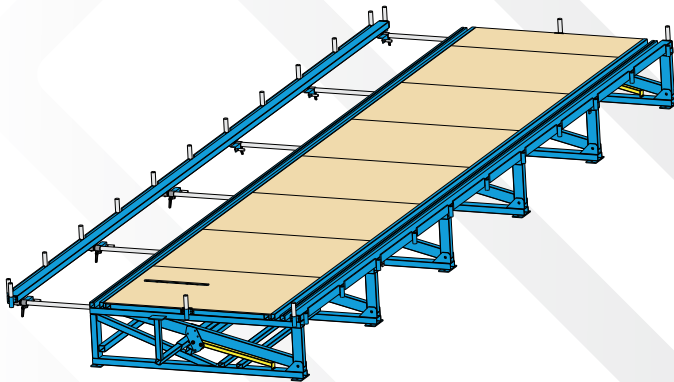

FUNCTIONAL DESCRIPTION

- Adjust the width of the table
- Build the timber framework directly of the table, top/bottom plate and studs
- Square the building element to 90 degree building element with high quality
- Nail the timber frame work form both sides
- Perform manual operations such as installation, insulation, nailing of boards etc
- Initiate the turning process, the receiver table and upraise table is erected and the building element is turned

Included

Option

BS10U - Basic design		
Function		
Hydraulic Turning - 90 degrees	One choice	
Hydraulic Turning - 80 degrees		
No Turning		
Fixed rollers, 2 rows	One choice	
Fixed rollers, 3 rows		
Upraisable Rollers, 2 rows		
Upraisable Rollers, 3 rows		
Manual Width Adjustment - No squaring		
Manual Width Adjustment - Pneumatic squaring	One choice	
Extended Manual Width Adjustment - Pneumatic squaring		
Hydraulic Width Adjustment - Hydraulic squaring		
Extended Hydraulic Width Adjustment - Hydraulic squaring		
C-Bars, Across		
Hole Beams, Across		
Hole Beams, Short side (2 pc)		
Vertical Outfeed of Wall Element		
Air Supply for Pneumatic Tools		
Plywood		
C-bars, Lengthwise		
Removable support pins (fixed side)		
Removable support pins (movable side)		
Removable support pins (short side)		

Technical description	BS10U-060	BS10U-075	BS10U-090	BS10U-120
Timber Framework - Length	6000 mm	7500 mm	9000 mm	12000 mm
Max lift capacity (element height = 2,5 m)*	1000 kg	790 kg	1450 kg	2000 kg
Article number - Basic upraiser design	119067AA	119068AA	119069AA	119070AA
Working height	620 mm			
Timber Framework - Thickness	63 - 300 mm (element thickness is limited by weight)			
Timber Framework - Height	2250 - 3100 mm (option 100-3650 mm)			
Safety	The machine is equipped with emergency stop			
Consumption - Electricity	3 x 400 VAC +N +PE 16A 50 Hz			
Consumption - Air	7 bar			
* Increased max lift capacity upon request				

RECEIVER TABLE BS10R

Receiver Table BS10R is normally the second table that receives the building element after the turning. The table is covered with plywood. Removable support pins for turning of the element are placed on one side of the table.

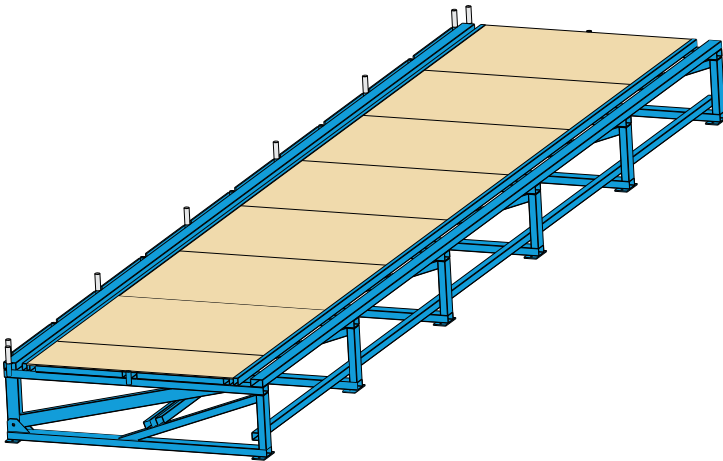

Included

Option

BS10U - Basic design

Function

Hydraulic Turning - 90 degrees	One choice	<input checked="" type="checkbox"/>
Hydraulic Turning - 80 degrees	One choice	<input type="checkbox"/>
No Turning	One choice	<input type="checkbox"/>
Fixed rollers, 2 rows	One choice	<input type="checkbox"/>
Fixed rollers, 3 rows	One choice	<input type="checkbox"/>
Upraisable Rollers, 2 rows	One choice	<input type="checkbox"/>
Upraisable Rollers, 3 rows	One choice	<input type="checkbox"/>
Manual Width Adjustment - No squaring	One choice	<input type="checkbox"/>
Manual Width Adjustment - Pneumatic squaring	One choice	<input type="checkbox"/>
Extended Manual Width Adjustment - Pneumatic squaring	One choice	<input type="checkbox"/>
Hydraulic Width Adjustment - Hydraulic squaring	One choice	<input type="checkbox"/>
Extended Hydraulic Width Adjustment - Hydraulic squaring	One choice	<input type="checkbox"/>
C-Bars, Across		<input type="checkbox"/>
Hole Beams, Across		<input type="checkbox"/>
Hole Beams, Short side (2 pc)		<input type="checkbox"/>
Vertical Outfeed of Wall Element		<input type="checkbox"/>
Air Supply for Pneumatic Tools		<input type="checkbox"/>
Plywood		<input checked="" type="checkbox"/>
C-bars, Lengthwise		<input checked="" type="checkbox"/>
Removable support pins (fixed side)		<input checked="" type="checkbox"/>
Removable support pins (movable side)		<input type="checkbox"/>
Removable support pins (short side)		<input checked="" type="checkbox"/>

FUNCTIONAL DESCRIPTION

- Continue the turning process and lower the wall. Both upraise and receiver table are lowered and the building element is turned over.
- Perform manual operations such as: installation, insulation, board nailing etc
- Fasten the lifting straps to a conveyor system or to other lifting equipment. Raise the table and pull the building element using the conveyor system at the same time. When reaching 90 degrees the building element is removed from the working station.

Technical description	BS10R-060	BS10R-075	BS10R-090	BS10R-120
Timber Framework - Length	6000 mm	7500 mm	9000 mm	12000 mm
Max lift capacity (element height = 2,5 m)*	1000 kg	790 kg	1450 kg	2000 kg
Article number - Basic receiver design	119071AA	119072AA	119073AA	119074AA
Working height	620 mm			
Timber Framework - Thickness	63 - 300 mm (element thickness is limited by weight)			
Timber Framework - Height	2250 - 3100 mm (option 100-3650 mm)			
Safety	The machine is equipped with emergency stop			
Consumption - Air	Supplied from the upraising table			
* Increased max lift capacity upon request				

EXAMPLE CONFIGURATION

SEPARATE UPRAISER BS10U

BS20 1-table solution is used when producing open panels, curtain walls or other open component (floor, roof).

POSITION A (OPERATIONS: BUILD FRAME WORK, BOARD NAILING)

Hole Beams BS2HBL as an option adding flexibility in case of production of building elements less than 2250 mm in height or when producing angled shaped walls etc.

As clamping system Hydraulic Squaring BS2HC or Pneumatic Squaring BS2CR. Extended Width Adjustment BS2IW in case of production of elements higher than 3100 mm (< 3650 mm). The Vertical Outfeed of Wall Elements RS2RVP is used when the walls shall be fed from the machine in vertical position.

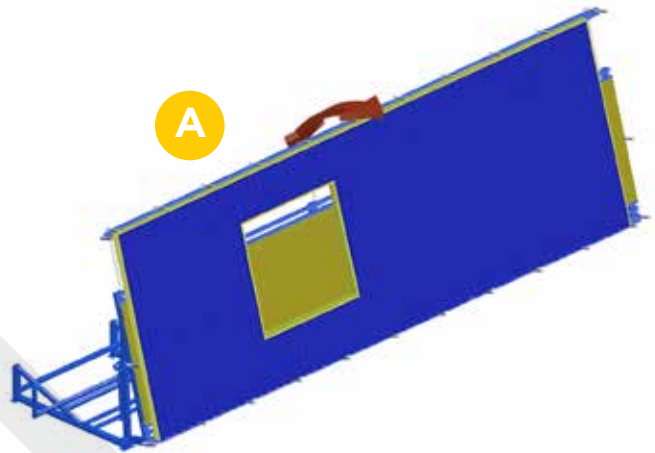

EXAMPLE CONFIGURATION

2-TABLE SOLUTION

STANDARD BS20-SYSTEM

BS20 2-table solution is the standard original layout that is used by producer throughout the world. In this station it is possible to produce insulated walls, floors and roofs.

POSITION A (OPERATIONS: BUILD FRAME WORK, BOARD NAILING)

Hole Beams BS2HBL as an option

adding flexibility in case of production of building elements less than 2250 mm in height or when producing angled shape walls etc. As clamping system Hydraulic Squaring BS2HC or Pneumatic Squaring BS2CR. Extended Width Adjustment BS2IW in case of production of elements higher than 3100 mm (< 3650 mm).

POSITION B (OPERATIONS: INSULATION, BOARD/CLADDING NAILING)

The Vertical Outfeed of Wall Elements RS2RVP is used when the walls shall be fed from the machine in vertical position.

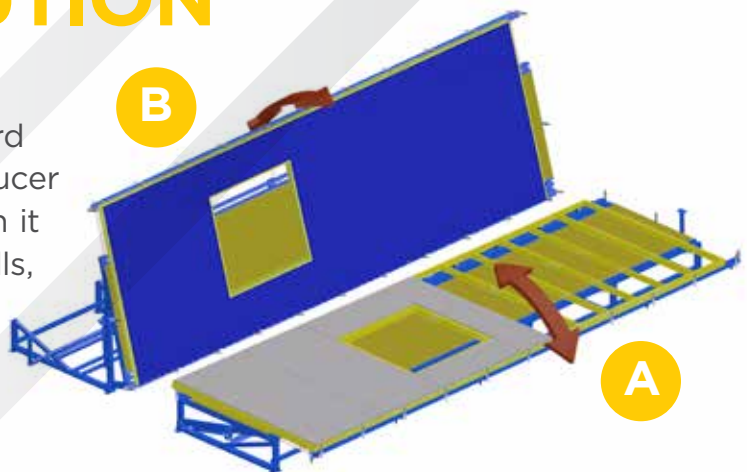

EXAMPLE CONFIGURATION

3-TABLE SOLUTION

BS20 WITH EXTRA STATION

This 3-table solution the working processes after turning which in general is more time demanding than the working processes before turning has been divided into 2 stations in order to increase the capacity. In this line it is possible to produce insulated walls, floors and roofs.

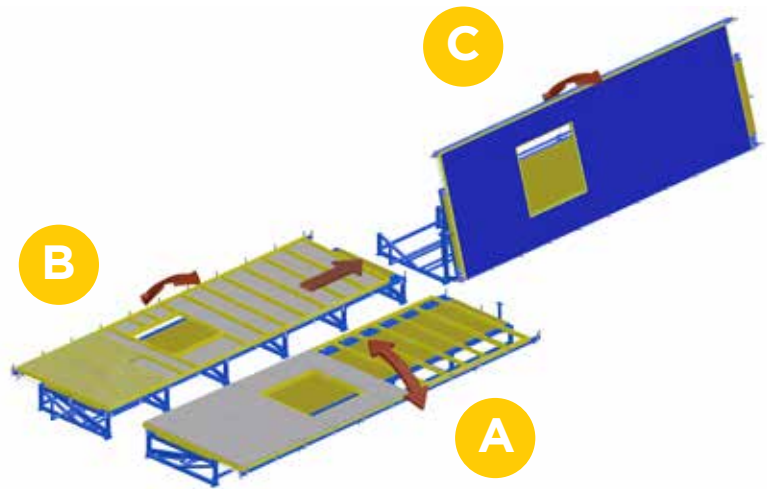

The system can be configured with a transport system with

Upraisable Rollers BS2RL or Fixed Rollers BS2FR. Rollers (page 11) must be used in the first station where the framework is built. As clamping system Hydraulic Squaring BS2HC or Pneumatic Squaring BS2CR. Extended Width Adjustment BS2IW in case of production of elements higher than 3100 mm (< 3650 mm).

POSITION A (OPERATIONS: BUILD FRAMEWORK, BOARD NAILING)

Hole Beams BS2HBL as an option adding flexibility in case of production of building elements less than 2250 mm in height or when producing angled shape walls etc. In order to be able to transport elements less than 2250 mm in height after turning the stations needs to have a "third" roller conveyor.

POSITION B (OPERATIONS: INSULATION, BOARD NAILING)

Upraisable Roller (3 rows) BS2RL3 or Fixed Roller (3 rows) BS2FR3 to be able to transport elements less than 2250 mm in height.

POSITION C (OPERATIONS: NAILING OF CLADDING ETC)

The Vertical Outfeed of Wall Elements RS2RVP is used when the walls shall be fed from the machine in vertical position.

EXAMPLE CONFIGURATION

4-TABLE SOLUTION

BS20 WITH FRAMING STATION AND EXTRA STATION

Here we have solution consisting of 4-tables forming a production line. We fully utilize the effectiveness achieved by producing in a line. In this line it is possible to produce insulated walls, floors and roofs.

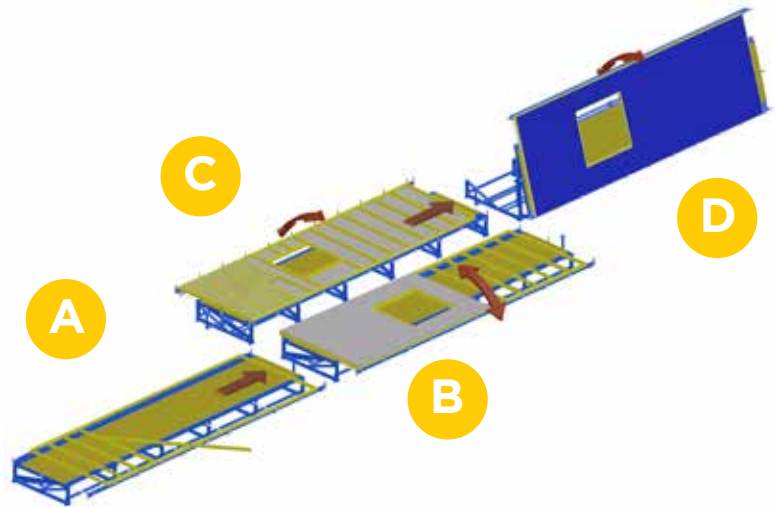

The system can be configured with a transport system with

Upraisable Rollers BS2RL or Fixed Rollers BS2FR. Rollers (page 11) must be used in the first station where the framework is built. As clamping system Hydraulic Squaring BS2HC or Pneumatic Squaring BS2CR. Extended Width Adjustment BS2IW in case of production of elements higher than 3100 mm (< 3650 mm).

POSITION A (OPERATIONS: BUILD FRAME WORK)

Hole Beams BS2HBL as option adding extra flexibility i.e. when producing angled shape walls etc.

POSITION B (OPERATIONS: BOARD NAILING)

Hole beams BS2HBL is listed as an option also in this station in case of production of building elements less than 2250 mm in height. When producing these small elements this station (B) will act as the first station. In order to be able to transport the element after turning the stations needs to have a "third" roller conveyor.

POSITION C (OPERATIONS: INSULATION, BOARD NAILING)

Upraisable Roller (3 rows) BS2RL3 or Fixed Rollers (3 rows) BS2FR3 to be able to transport elements less than 2250 mm in height.



































































































POSITION D (OPERATIONS: NAILING OF CLADDING ETC)

The Vertical Outfeed of Wall Elements RS2RVP is used when the elements shall be fed from the machine in vertical position.

EQUIPMENT AND FUNCTIONS

IN THE EXAMPLE CONFIGURATIONS

Below are functions for the example configurations listed. BS20 is developed as a flexible module based system where the options can be added to fit the production of each customer.

Option	Model	Page		1-table solution	2-table solution	3-table solution	4-table solution
				A	B	A B C	D A B C
 Chosen option							
 Other recommended options							
Possible options							
 Options not allowed in this configuration							
Hydraulic Turning - 90 degrees	BS2-T9	12	One choice		 	  	   
Hydraulic Turning - 80 degrees	BS2-T8	12			 	  	   
Fixed Rollers (2 rows)	BS2-FR2	11	One choice			  	   
Fixed Rollers (3 rows)	BS2-FR3	11				  	   
Upraisable Rollers (2 rows)	BS2-RL2	11				 	   
Upraisable Rollers (3 rows)	BS2-RL3	11				 	   
Manual Width Adjustment (no squaring)	BS2-MW3100	14	One choice			 	   
Manual Width Adjustment Pneumatic Squaring	BS2-MW3100P	14				  	   
Extended Manual Width Adjustment Pneumatic Squaring	BS2-MW3650PS	14				  	   
Hydraulic Width Adjustment and Squaring	BS2-HW3100HS	14				  	   
Extended Hydraulic Width Adjustment and Squaring	BS2-HW3650HS	14				  	   
C-bars, Across	BS2-C	13					
Hole Beams, Across	BS2-HBL	13					 
Hole beams, Short side	BS2-HBC	13					
Vertical Outfeed of Wall Element	BS2-RVP	16					
Air Supply Pneumatic Tools	BS2-XA	17					

CONFIGURE YOUR BUTTERFLY TABLE

Detailed description of each function follows on the next pages in this brochure. Read through the descriptions in detail and chose the functions fitting your production, feel free to ask a Randek representative for assistance.

The base in the BS20-system is a standard machine that can be equipped with many different options and add-ons. The standard machine is built as an upraiser, receiver or a working table without hydraulic turning function in length 6.0, 7.5, 9.0 and 12.0 m. All options are possible to add to the standard machines and are available in the mentioned length steps.

Article number	Basic machine	Model	Station length
119000AA	Upraiser Table	BS10U-060	6000 mm
119000AB	Upraiser Table	BS10U-075	7500 mm
119000AC	Upraiser Table	BS10U-090	9000 mm
119000AD	Upraiser Table	BS10U-120	12000 mm
119001AA	Receiver Table	BS10R-060	6000 mm
119001AB	Receiver Table	BS10R-075	7500 mm
119001AC	Receiver Table	BS10R-090	9000 mm
119001AD	Receiver Table	BS10R-120	12000 mm
119123AA	Working Table	BS05-060	6000 mm
119123AB	Working Table	BS05-075	7500 mm
119123AC	Working Table	BS05-090	9000 mm
119123AD	Working Table	BS05-120	12000 mm
To configure a receiver or upraiser you need – besides the basic machine – to choose hydraulic turning (page 12) and the horizontal transport option (page 11). For Working Table the horizontal transport option needs to be chosen (page 11).			

HORIZONTAL TRANSPORT OF ELEMENT - BS2-R

Rollers for transport of elements in horizontal position enables production lines with BS20 system.

All BS05/10/20-tables can be equipped with rollers for transport of elements in horizontal position. The rollers can be fixed or upraisable. The rollers are placed on top and bottom plate of the element in order not to damage the element. The roller system consists of two rollers whereof one is placed on the width adjustment function to be able to position on the top plate for all element widths. The transport of the building element is easily done by manually pushing the element forward. It is also possible to place an extra roller on the middle of the table. The purpose of this extra roller is to be able to transport building elements lower than 2250 mm in width after being turned, the elements needs to be covered with boards (see 3- or 4-table solution in the example layouts).

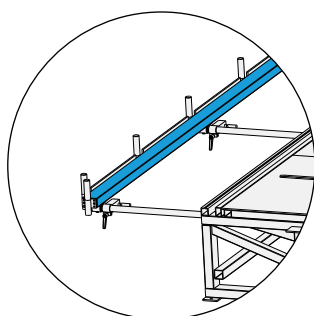

- Rollers for effective transport of building element in horizontal position
- Fixed or upraisable rollers
- Take advantage of the effectiveness benefits by producing in line with BS20 system

FUNCTIONAL DESCRIPTION UPRAISABLE ROLLERS

- Build the timber frame work efficiently and qualitatively using the squaring function BS2CR or BS2HC
- Raise the rollers and push the element forward to the next station
- Lower the rollers

				Required choice			
Article Number		Option		Model	Roller rows		
6 meter	7,5 meter	9 meter	12 meter				
118972AA	118972AB	118972AC	118972AD	No Transport	BS2-NR	2	
118973AA	118973AB	118973AC	118973AD	Fixed Rollers	BS2-FR	2	
118973AE	118973AF	118973AG	118973AH	Fixed Rollers	BS2-FR3	3	
118974AA	118974AB	118974AC	118974AD	Upraisable Rollers	BS2-RL	2	
118974AE	118974AF	118974AG	118974AH	Upraisable Rollers	BS2-RL3	3	
Rollers needs to have the option "Width Adjustment" (page 14) in order to vary width of the table.							

HYDRAULIC TURNING BS2-T



Safe and effective turning of building elements with the hydraulic turning function. BS10/20 tables are equipped with the hydraulic turning function. The upraise level is 90-degrees for turning function and 80-degrees for upraise function. The turning/upraising is easily performed by the operator using a control unit placed separated from the tables. The turning function is performed by hydraulic cylinders fed from hydraulic unit.

- Safe, effective and non-damaging turning of walls/building elements
- Upraise or Turning function

FUNCTIONAL DESCRIPTION TURNING FUNCTION

- The receiver table is raised to 90-degrees and then the upraise table is raised
- The receiver table is lowered and the building element is turned; safe, effective and non-damaging. The upraise table is lowered.
- The building element is finalized
- The receiver table is raised and the wall element is transported using a conveyor system or by using Vertical Outfeed of Wall Element BS2-RVP

Article Number				Option	Model	Upraising degree	Incl. Hydraulic agg. **
6 meter	7,5 meter	9 meter	12 meter	If basic machine BS10U or BS10R is chosen, one of the following options must be selected.			
118971AA	118971AB	118971AC	118971AD	Hydraulic turning	BS2T90S	90 degrees	No
118971AE	118971AF	118971AG	118971AH	Hydraulic turning	BS2T90M	90 degrees	Yes
118971AI	118971AJ	118971AK	118971AL	Hydraulic turning	BS2T80S	80 degrees*	No
118971AM	118971AN	118971AO	118971AP	Hydraulic turning	BS2T80M	80 degrees*	Yes
*To be used when the element shall be lifted off with forklift or conveyor to avoid element from falling. **The hydraulic unit can feed two tables in total - normally an upraiser and a receiver. Hydraulic hoses are then connected between the tables. This option cannot be combined with basic machine BS05 (working tables have no turning function by definition)							

FLEXIBLE SUPPORT



FLEXIBLE SUPPORT FOR BUILDING ELEMENTS USING C-BARS AND HOLE BEAMS.

To be able to produce building elements of almost any type and shape the BS20 system can be expanded with extra support features; C-Bars and Hole Beams.

C-BARS

C-bars make it possible to place support devices running in the C-bars, the standard configuration of the BS20-system has 2 C-bars running along the table on each side. To be used to indicate where to place studs etc, as option C-bars can be placed across the table.

HOLE BEAMS

Hole beams enables flexible support and clamping. In the hole beams the same support pins placed along the table can be placed, thus making it possible to produce building elements less than 2250 mm in width. It is also possible to place movable clamping cylinders for extra clamping function when producing i.e. angled shape building elements or when need for clamping from inside of the element towards the support pins. The hole beams are placed across the table or on the short side of the table for clamping towards the short side of the building element.

- Flexible clamping and support with C-bars and hole beams
- Enables production of short and angled shape building elements
- Extra pneumatic clamping from all angles



Article Number				Option	Model	Roller rows
6 meter	7,5 meter	9 meter	12 meter			
118975AA	118975AB	118975AC	118975AD	C-Bars, Across	BS2-C2	2
118975AE	118975AF	118975AG	118975AH	C-Bars, Across	BS2-C3	3
118976AA	118976AB	118976AC	118976AD	Hole Beams, Across	BS2-HBL	2
118976AE	118976AF	118976AG	118976AH	Hole Beams, Across	BS2-HBL3	3
118977AA				Hole Beams, Short side (2 pc)	BS2-HBC	2 or 3

WIDTH ADJUSTMENT AND SQUARING - BS2-W



EFFECTIVE PRODUCTION OF BUILDING ELEMENTS WITH THE SQUARING AND WIDTH ADJUSTMENT FUNCTION.

The squaring function clamps and straighten the timber frame work pneumatic or hydraulic to a 90-degree angled shape and eliminates bow shaped

timber. The width adjustment function enables a flexible production where building elements with different widths can be efficiently produced.

SQUARING FUNCTION

The working table has 160 mm high support pins on all sides of the table whereof one long side is adjustable in width and can be equipped with pneumatic or hydraulic squaring function. It is the support pins that are pushed against the timber frame work, thus squaring it to a 90-degree shape and eliminating bow shaped timber. Both short sides of the table are also equipped with support pins.

WIDTH ADJUSTMENT FUNCTION

Flexibility is achieved by the width adjustment function. The adjustment of different widths on the building element (wall heights) is easily done from 2250 - 3100 mm, as option the interval can be extended 100 - 3650 mm. Extended Width Adjustment BS2EWA expands the width adjustment to 3650 mm and Hole Beams makes it possible to lower the minimum width from standard 2250 mm to desired width (wall height). When using the pneumatic system the adjustment is done by releasing the width adjustment side and manually pulling it outwards. The hydraulic system does the adjustment automatically by activating the hydraulic system that is also used as squaring function.

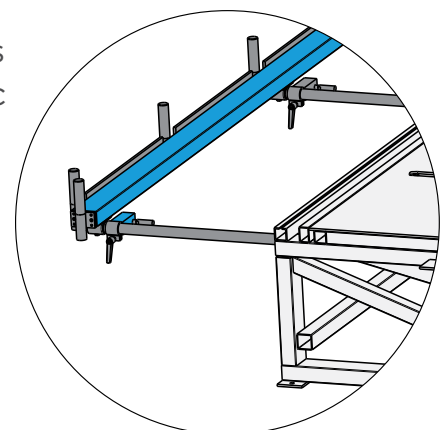

3D-view of the manual width adjustment with pneumatic squaring (BS2-MW3100P)

FUNCTIONAL DESCRIPTION

- The width (wall height) is set-up with the widths adjustment function, manually for pneumatic system and automatically for hydraulic system.
- Studs and top/bottom plates are placed on the table
- The building element is squared to 90-degree element and bow shaped timber is eliminated
- The timber frame work with boards is nailed fixating the squared 90-degree element
- The squaring function is deactivated and the building element is turned or transported further depending on configuration of total system



View showing hydraulic width and squaring function
(BS2- HW3100HS)

- Squaring to 90-degree building elements with minimized bow shaped timber
- Flexible production of building elements with widths (wall heights) between 100 - 3650 mm

Article Number				Option	Model	Wall height	Squaring	Support
6 meter	7,5 meter	9 meter	12 meter					
118978AA	118978AB	118978AC	118978AD	Width Adjustment	BS2-MW3100	3100*	No	No
118978AE	118978AF	118978AG	118978AH	Width Adjustment	BS2-MW3100S	3100*	No	Yes
118978AI	118978AJ	118978AK	118978AL	Width Adjustment	BS2-MW3100P	3100*	Pneum.	No
118978AM	118978AN	118978AO	118978AP	Width Adjustment	BS2-MW3100PS	3100*	Pneum.	Yes
118978AQ	118978AR	118978AS	118978AT	Extended Width Adjustment	BS2-MW3650S	3650*	No	Yes
118978AU	118978AV	118978AW	118978AX	Extended Width Adjustment	BS2-MW3650PS	3650*	Pneum.	Yes
118979AA	118979AB	118979AC	118979AD	Hydraulic Width Adjustment	BS2-HW3100HS	3100*	Hydr.	Yes
118979AE	118979AF	118979AG	118979AH	Extended Hydraulic Width Adjustment	BS2-HW3650HS	3650*	Hydr.	Yes
*Minimum squaring width (wall height) is 2250mm on all tables. Support must be used when the table is equipped with fixed rollers or upraisable rollers.								

VERTICAL OUTFEED OF WALL

ELEMENT BS2-RVP

OUTFEED OF WALL ELEMENT IN VERTICAL POSITION FOR EFFECTIVE PRODUCTION, HANDLING AND TRANSPORT.

The upraise table has support pins equipped with rollers enabling outfeed of wall element in vertical position when the upraise table is erected. The wall element is fed out from the upraise table onto wall wagons placed on a rail or onto an outfeed track equipped with rollers. Then further to a stock system alternatively to a working station where manual process such as window mounting, stucco etc. can be performed. Processes that are done more effective when the wall is in vertical position compared to horizontal, thus making productivity higher in the house factory.



View showing a vertical stock system. Can be fed directly from BS20-system when equipped with option BS2-RVP.

- Outfeed of the wall element in vertical position
- No (less) need for conveyor
- Perform working processes effectively for walls in vertical position
- Transport the walls directly to a vertical stock system

FUNCTIONAL DESCRIPTION

- The wall is erected with an upraise table to vertical position
- The wall is fed out in vertical position on support pins equipped with rollers further to adjacent wall wagons placed on a rail alternatively to an outfeed track equipped with rollers
- The wall element is placed on a vertical stock system alternatively are manual processes performed suitable for walls in vertical position such as window mounting, stucco etc.

Article Number				Option	Model
6 meter	7,5 meter	9 meter	12 meter	Vertical Outfeed of Wall Element	BS2-RVP
118969AA	118969AB	118969AC	118969AD		

AIR SUPPLY FOR PNEUMATIC TOOLS BS2-XA

CONNECT PNEUMATIC TOOLS DIRECTLY ON THE WORKING TABLE FOR EFFECTIVE PRODUCTION.

2 pcs of air supply placed at the centre of the long sides of the working tables. Pneumatic tools can be connected directly to the table minimizing loose air hoses on the production floor; the time for connecting pneumatic tools is also minimized.



- Connect pneumatic tools directly to the working tables
- Minimize air hoses on the production floor
- Effective production

Article Number				Option	Model
6 meter	7,5 meter	9 meter	12 meter		
118970AA	118970AB	118970AC	118970AD	Air Supply for Pneumatic Tools	BS2-XA

ACCESSORIES

To Randek BS20 system there are a number of accessories and equipment that can be integrated to the tables and production lines.

Article Number	Name	Model	Description
112783AA	Clamping Cylinder	BS3-CC	Placement in hole beam, Press force 1870 N at 6 bar.
GP01039	Round Support	BS2-S	Support for C-bars
114391AA	Foil Holder	HFM002	Length: 3700 mm, Height: 850-1350 mm
114391AB	Foil Holder	HFM002	Length: 3700 mm, Height: 450-600 mm

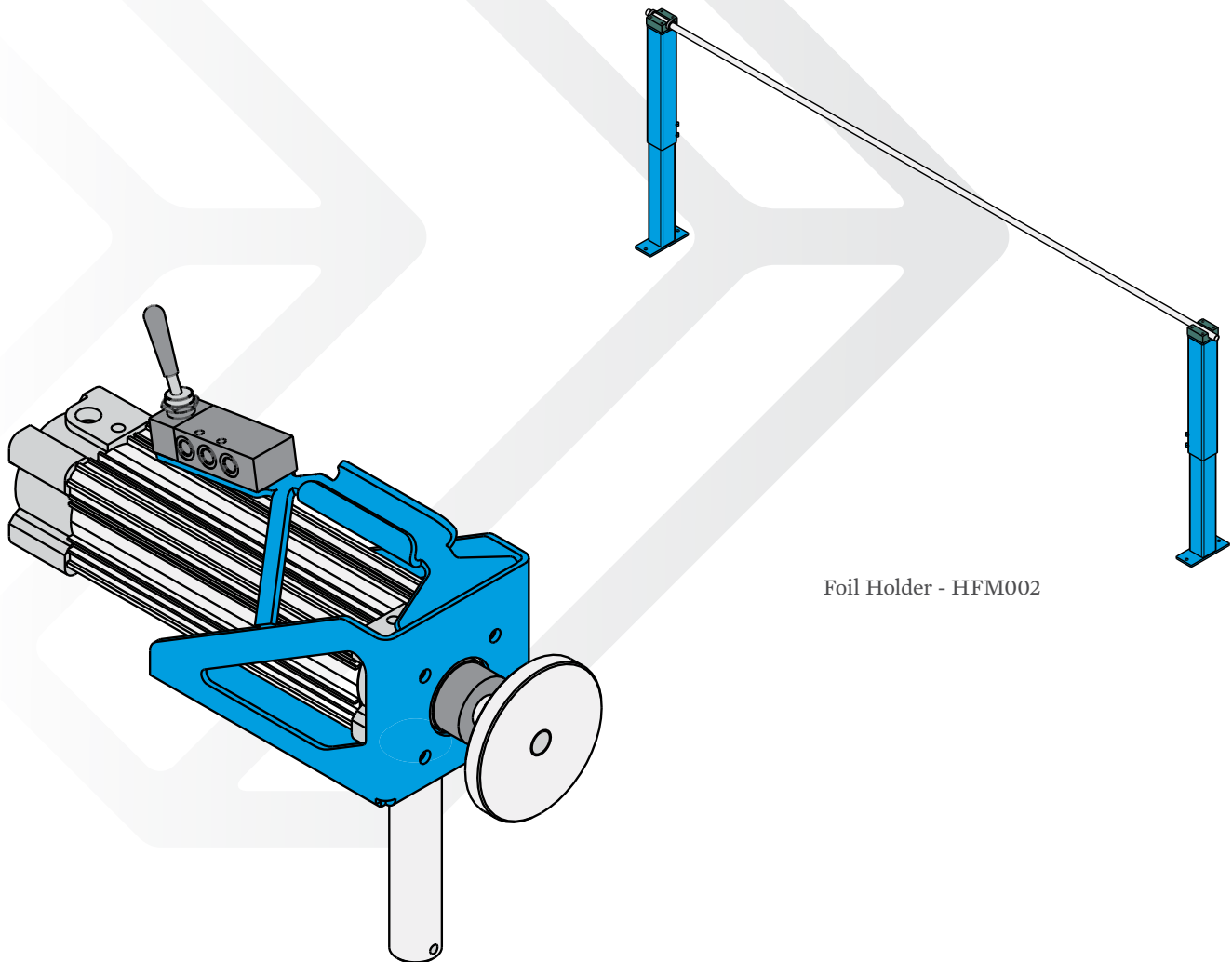

Movable Clamping Cylinder - BS3-CC

Foil Holder - HFM002

RANDEK IN BRIEF

Randek develops, manufactures and markets high-performance machines and systems for prefabricated house manufacturing. The product range consist of: cut saws, wall-, floor- and roof lines, roof truss system, butterfly tables and special machines. The automation level stretches from fully automated to manual.

The company history goes back to the 1940s and began working in close cooperation with the first prefabricating house producers. Today leading house producers in 38 countries are using Randek machines and system.

CUT SAWS

High quality and well tested saws with different automation levels. Also specialized saws for custom applications.



WALL-, ROOF- AND FLOOR LINES

Complete product program for manufacturing of walls, floors and roofs. From manual to fully automatic systems.



ROOF TRUSS SYSTEMS

Adapted equipment for rational manufacturing of roof trusses. From traditional systems to fully automatic.



BUTTERFLY TABLES

Flexible and well tested butterfly tables. Simple or advanced with a wide range of options.



SPECIALIZED MACHINERY

Customized machinery developed for specific applications, Automatic stucco machine, Beam insulating machine, Roof board machine and Window frame machine.



SERVICES

A wide range of services such as Factory Layout designs, Machine maintenance, House building systems and Financing.

