

THE PERFECT CUT



THE MACHINE COMPANY SINCE 1955



HISTORY

The basic idea of the horizontal bandsaw originated from carpentry in mountain regions. The possibilities were very limited at that time: logs had to be transported to a sawmill in the valley by ox team or horse team and then brought back to the mountains, or else hewn by hand. In the 1950s, carpenter Johann Resch came up with the idea of bringing the saw to the wood instead. He started developing his first bandsaw in the fall of 1954 and was already able to make his first test cuts on 14 February, 1955. Since then, bandsaws have been further refined based on a wealth of practical experience and adapted to the progress of technology and aesthetic criteria.

Widespread practical use led to a demand for a variety of accessories and extensions, which were also developed. Resch systems are now used in many different countries to the full satisfaction of customers.



TRANSFER

After operating the company for fifty years, Johann and Ignaz Resch handed it over to three of their long-term employees in January 2006. The new team of entrepreneurs is working hard and successfully to transform the full wealth of experience accumulated during these fifty years into further product development. With considerable flair and a new design, Resch & 3 is carrying on the tradition of producing top-quality machines.

KNOW-HOW

All products and components are produced at the company's headquarters in Blumau, starting with technical planning. Every machine that leaves our factory is subject to strict quality control. This way we guarantee our customers that Resch & 3 provides only the best equipment for their demanding jobs.



MOBILE BANDSAW

The professional mobile bandsaws type PROFI leave nothing to be desired. The entire system can be controlled precisely from the comfortable, ergonomically designed operator cab using two joysticks and a display screen. The mobile version is usually fitted with a diesel engine, and thanks to a variety of hydraulic functions it can be dismantled quickly and erected again at a different location.

Rapid transport. The mobile sawmill is designed for easy transport, including the edging unit and log infeed conveyor. It is approved for road transport up to 40 km/h (optionally up to 80 km/h). Thanks to the six hydraulic support legs, hydraulically unfolded extensions and hydraulic pivoting fixture, the entire system can be erected and aligned within a few minutes after arriving on site.



STATIONARY BANDSAW

The professional version of the stationary bandsaw is equipped with the same convenient features. All processing steps can be controlled precisely from the comfortable, ergonomically designed operator cab using two joysticks and a display screen. Costly concrete foundations are not necessary here. Stationary sawmills are usually fitted with an electric motor. However, a diesel engine is used if the mains electrical connection cannot provide sufficient power. The machine can also be automated using various types of feed chains and roller conveyors.



CAB

The travelling cab lets the operator work in a pleasant, low-noise, dust-free environment. The entire system is operated using a display screen and two joysticks. A direct view of the sawn timber ensures constant quality control. The cutting height setting can be adjusted easily for optimum log utilization using several predefined cutting programs. Several options are also available from Resch & 3, such as cab heating, xenon exterior lighting, seat heating, radio.



PRECUTTER

Precutters at both sides of the log trim dirty sections of its bark to provide clean entrance and exit cuts for the saw blade. This dramatically increases the service life of the saw teeth. The two precutters can be controlled individually.



CROSSCUTTER

During cutting, each plank can be trimmed automatically to the desired length. Finished lengths of long timber can thus be taken directly from the mill. The hydraulically actuated cross-cutter can optionally be rotated by 90° degrees so it can be used as a ripping saw. Particularly with hardwood, this can be used to part the heartwood or edge one side. The maximum cutting depth of the crosscutter is 80 mm.



PRESSURE GUIDES

The pressure guides improve the stability and reliability of the sawblade guidance system. As a result, precise cutting is possible even at elevated feed rates. Each guide can be moved individually to position it as close as possible to the log.



SAWBLADE REPLACEMENT

For sawblade replacement, the pressure on the blade tensioning system can be released from the cab and the protective housing is opened hydraulically. The sawblade can be easily removed and replaced. The machine is ready for use again in almost no time.



SAWDUST BOX

Sawdust is collected in a dedicated container, which is emptied automatically when the saw returns to the end position.



LOG LOADER

The hydraulic log loader lifts each log onto the guideway. After this, it can be processed into timber.



TURNING CHAINS

Logs of various sizes and shapes, as well as cants and planks, can be easily rotated into the desired position using the turning chains. The turning chains are also used to eject sawn timber.



LONGITUDINAL ROLLERS

Longitudinal rollers transport the log back and forth for optimal utilisation of the clamping tongs. The log is thus optimally secured.



CLAMPING TONGS

Clamping tongs that can be individually adjusted in height are used to align and secure the log to ensure a perfect horizontal positioning of the log.



SQUARING

The material to be cut is aligned to the right angle for sawing square timber, slats or planks. A supplementary fine adjustment can be used to tilt the cant. The angle can be corrected as necessary using this adjustment.



LOG INFEED

The hydraulic log infeed conveyor transports the wood to the log loader. Several logs can be loaded onto the conveyor at the same time.

Another accessory simplifies transporting sawn timber to the edging saw. The plank outfeed can be controlled from the cab or the edging saw. (no picture)

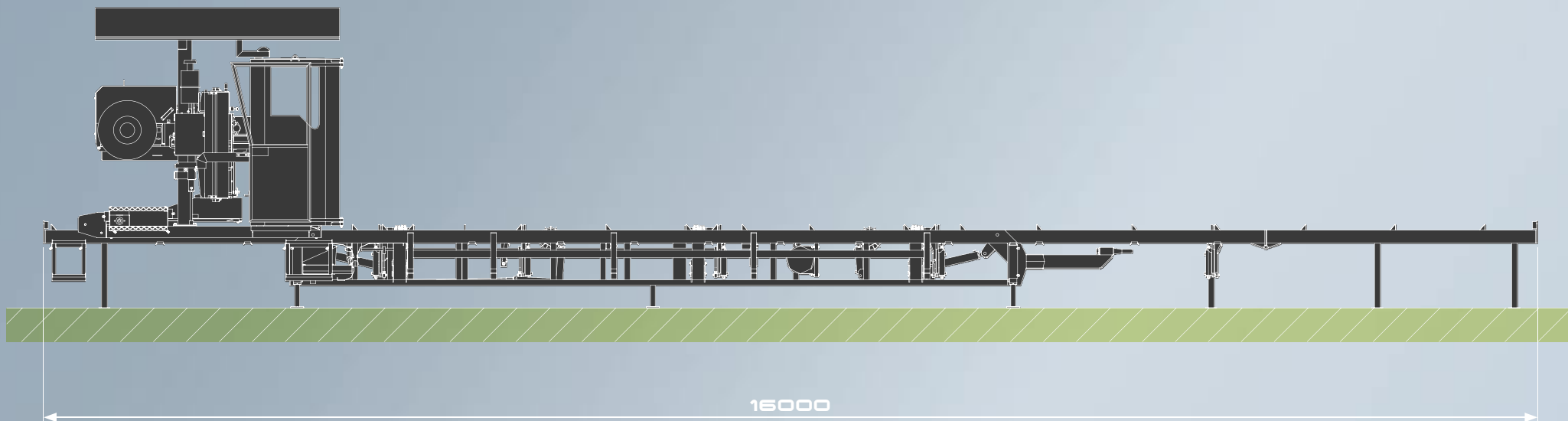

TECHNICAL DATA

		Type 1050	Type 1200
S	Maximum log clearance	1100 mm	1500 mm
F	Wheel diameter	1050 mm	1200 mm
	Wheel width	95 mm	105 mm
C	Offcut thickness	25 mm	25 mm
H	Maximum stroke	960 mm	960 mm
E	Maximum depth of cut	360 mm	440 mm
B	Track width	1300 mm	1500 mm
HG	Overall height	3000 mm	3400 mm

		Type 1050	Type 1200
BG	Overall width	3800 mm	4300 mm
BS	Overall saw width	3200 mm	3700 mm
	Sawblade length	6500 mm	7500 mm
	Sawblade width	120 mm	130 mm
	Sawblade thickness	1.2 mm	1.2 mm
	Cutting length (customer-specified)	13 m standard	13 m standard
	Continuously adjustable hydraulic feed	0 - 40 m/min	0 - 40 m/min
	Main drive: diesel engine / electric motor	54 KW / 30KW	81 KW / 45KW

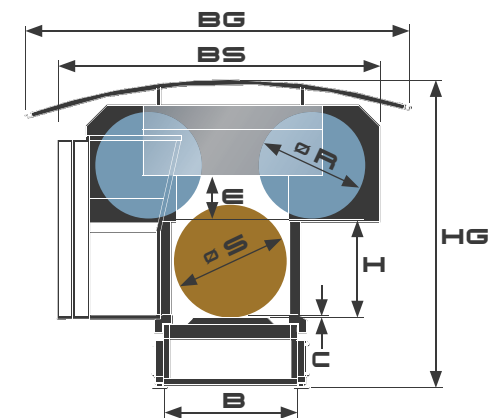

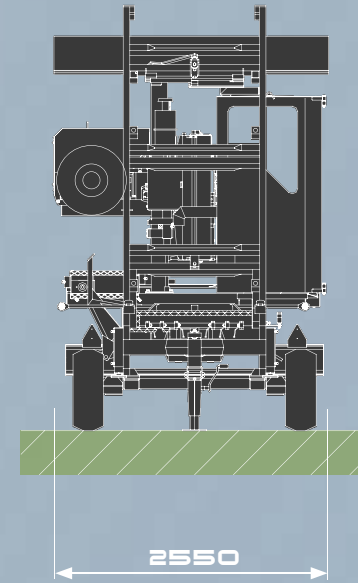
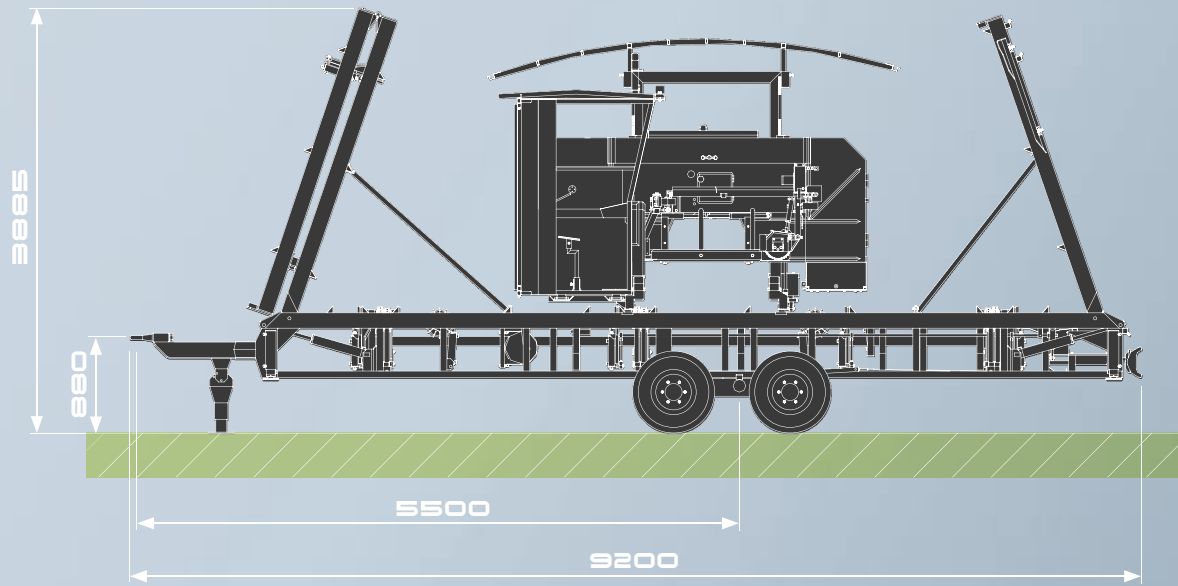

TRANSPORT

To ensure compliance with road traffic standards, the sawhead must be rotated by 90 degrees using a hydraulic turning fixture and then secured for safe transport. A central tandem axle ensures the manoeuvrability of the overall system and provides the smoothest possible travel characteristics. The standard braking system of our machines works with compressed air. If desired, a hydraulically actuated system can be fitted instead. The transport weight is approximately 7000 kg.



SIMPLE BANDSAW

As the name ECO ('economical') suggests, this model is a simple, inexpensive machine. Although it is not equipped with supplementary functions, it still guarantees stability and precision. It is operated using mushroom-head buttons, with the height setting being configured using a display. All functions are hydraulically actuated, and the feed rate is continuously adjustable. The ECO model does not have an operator cab, but has a protective pane for the operator instead that provides a full view of the entire working process.



LAMINATION BANDSAW

The answer to the growing demand for glulam beams: the TBS series with the Type 1050, Type 1200 and Type 1400 models. Options: pressure guides, automatically adjustable sawblade guides, blade monitoring system for automatic feed rate control, frequency inverter for motor speed control, cutting tilt adjustment 0–15 degrees, diagonal cutting adjustment 0–90 degrees, with roller conveyor and pressure roll, automatic side positioning for curved glulam beams.



AUTOMATIC SHARPENER

With the automatic sharpening and equalizing unit, you can sharpen dull blades right on site. Sharpening and equalizing are performed in a single operation. Thanks to its modular construction, this unit can be transported easily by car.

Sawblade width	Sawblade length	Tooth pitch
60 mm – 160 mm	5 m – 9 m	30 mm – 45 mm



TOOTH COMPRESSION DEVICE

Our product line also includes manual tooth compression devices. They are easy to use: the sawblade is secured and the tips of the teeth are compressed. After this, the automatic sharpening and equalizing unit is used to grind the teeth to the desired shape.



CIRCULAR EDGING SAW

The feed rate of this single-person edger can be adjusted continuously to obtain the optimum speed for different plank thicknesses. The plank remains stationary on the table, while the circular saw travels back and forth. The adjustable stop guide ensures that the plank is parallelly cut to the desired size. Lateral stops can be used for slat cutting.

Type	K 4400	K 5200	K 6200
Maximum length of cut	4400 mm	5200 mm	6200 mm
Maximum depth of cut	110 mm	110 mm	110 mm
Electric motor	5.5 KW	5.5 KW	5.5 KW
Feed	cont. adjustable	cont. adjustable	cont. adjustable
Weight	650 kg	700 kg	760 kg



BLADE TREATMENT

Rudolf Lantschner has mastered everything Johann Resch learned during his many years of experience. He looks after the soul of accurate cutting: the sawblade. Proper camber and adjustment of the sawblade wheels is an equally critical factor. Besides manufacturing its own wheels, Resch & 3 can use its special lathe to camber the sawblade wheels of other models with diameters up to 2 metres. Thanks to the company's experience and capabilities, many customers of other manufacturers turn to Resch & 3 for assistance.

SERVICE

Resch & 3 is committed to providing full after-sales support. Wear parts and replacement parts are always available from stock without avoidable delays, and our know-how is always available to our customers. Resch & 3 also considers it important to familiarise our customers with how our products work so they can master every processing operation. For this reason, in addition to comprehensive customer service we offer training to help customers use Resch & 3 machinery safely and reliably. It goes without saying that all of our machinery and accessories are CE and GS certified by the German Professional Association. Measured noise levels at the workplace are less than 85 dB.



PRODUCTION

Superior quality is assured when everything comes from a single source. This has always been the working philosophy of Resch & 3. At Resch & 3, all activities are conducted in-house, starting with the consulting and planning stage. The planning stage is followed by designing a virtual three-dimensional model on the computer. After a thorough examination of the design study, the machine goes into manufacturing.

Everything is genuine Resch & 3, and everything is checked meticulously for perfect quality. The entire production process is flexible and it is designed to accommodate the needs and requirements of our customers. In addition, thanks to our well-equipped machining centre and materials stock we are always able to produce a wide variety of individual parts on request.



Resch & 3 GmbH – Brennerstraße 44/a – I-39053 Blumau – T +39 0471 35 31 37 – F +39 0471 35 31 77 – info@resch-3.com – www.resch-3.com

