

BANDSAW

# COMPACT

### Our advantages

- We build your bandsaw to your custom dimension.
- As a full-range supplier, we also supply automatic sharpeners, single blade and double circular edging saws, bandsaw with automatic operation, as well bandsaw for glued laminated industries.
- We provide individual solutions for log infeed, plank outfeed and sorting of the sawn timber.
- Advice, planning, production, assembly and service from one source.
- Experience since 1955.

### Description type name:

<b>E</b>	<b>S</b>	<b>1050</b>	<b>COMPACT</b>
<b>Motorization</b>	<b>Version</b>	<b>Wheel Ø</b>	<b>Model</b>
<b>E</b> = Electric motor	<b>S</b> = Stationary	<b>1050</b>	<b>COMPACT</b>
<b>D</b> = Diesel engine	<b>M</b> = Mobile	<b>1200</b>	<b>PROFI</b>
		<b>1400</b>	

# COMPACT



Type	1050	1200	1400		
ØR Wheel diameter	1,050	1,200	1,400	mm	
ØS max. log diameter	1,250	1,500	2,000	mm	
E max. depth of cut	460	530	630	mm	
H max. stroke	1,100	1,200	1,500	mm	
C last cut residual measure	15	15	30	mm	
GB Overall width	3,000	3,500	4,150	mm	
GH Overall height	3,250	3,500	4,200	mm	
Sawblade width	120	130	180	mm	
Sawblade length	6,800	7,800	9,500	mm	
Sawblade thickness	1.2	1.2	1.47	mm	
Cutting length	customer-specified 6m standard				
Feed Avance	0 – 45	0 – 40	0 – 30	m/min	
Power sawblade	Electric motor	30 – 37	37 – 55	55 – 75	KW
	Diesel engine	65	85 – 120	120 – 186	KW
Total weight depending on the cutting length	min. 6,000	min. 8,000	min. 12,000	kg	

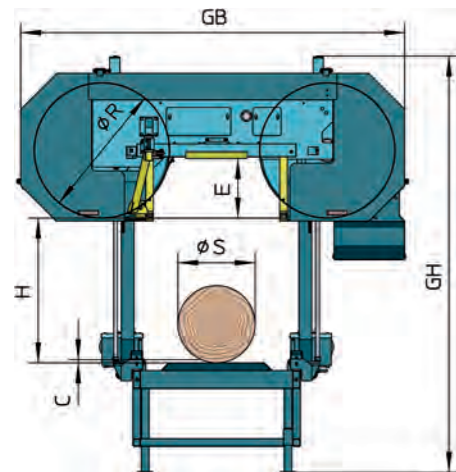

THE MACHINE COMPANY SINCE 1955

**RESCH & B GMBH**

I-39053 Blumau (South Tyrol) - Brennerstraße 44/a - T +39 0471 35 31 37 - F +39 0471 35 31 77 - [info@resch-3.com](mailto:info@resch-3.com) - [www.resch-3.com](http://www.resch-3.com)

# COMPACT

The operating station of the COMPACT Bandsaw is stationarily fixed to the ground behind the saw. All of the components of the sawhead and the guideway are identical to those of the PROFI machine. The saw blade pressure guide is also included. An extra lift of 1,100mm enables the machine to cut oversized timber (max. trunk diameter 1.25m). The new COMPACT Series is a robust, top-quality, "trimmed-down version of the PROFI machine".

The COMPACT Series is ideal for companies that work with a log frame or saw gate and are looking for a horizontal band-saw in order to cut into oversized trunks or to pre-cut or pre-shape oversized trunks in preparation for a resaw system. The cost/performance ration of the COMPACT Line is also of interest to newcomers.

**Precutter:** The precutter removes dirt and bark from trunks to allow the saw blade to perform a clean cut. This increases the service life of the saw teeth enormously.

**Pressure guides:** The pressure guides improve the stability and reliability of the sawblade guidance system. As a result, precise cutting is possible even at elevated feed rates. Both guides can be moved to position it as close as possible to the log.

**Control panel:** Simple and clearly structured. Various programmes on the display enable the operator to quickly enter the respective cutting thicknesses.

**Sawdust box:** Sawdust is collected in a dedicated container, which is emptied automatically when the saw returns to the end position.

**Height positioning:** Two hydraulic cylinders move the sawhead up and down. The height positioning is performed very quickly and with extreme precision.

**Feed:** The sawhead is directly driven on both sides via two geared motors. The optimum rate of feed is infinitely adjustable from 0-45m/min.



**Log loader:** The hydraulic log loader lifts each log onto the guideway. After this, it can be processed into timber.

**Turning chains:** Logs of various sizes and shapes, as well as cants and planks, can be easily rotated into the desired position using the turning chains. The turning chains are also used to eject sawn timber.

**Longitudinal roller:** The longitudinal roller transports the log back and forth for optimal utilisation of the clamping tongs. The log is thus optimally secured.

**Squaring:** The material to be cut is aligned to the right angle for sawing square timber, slats or planks. A supplementary fine adjustment can be used to tilt the cant. The angle can be corrected as necessary using this adjustment.

**Clamping tongs:** Clamping tongs that can be individually adjusted in height are used to align and secure the log to ensure a perfect horizontal positioning of the log.

**Minimum height:** An additional function positions the clamping tongs at the minimum height. Without cutting into the clamping tongs, the last cut can be made at 15mm.

**Outfeed rollers:** When sorting the sawn timber, it is important that the side cuts are separated from the finished cuts. While the planks are laid on their sides with the aid of the turning chains, the outfeed rollers transport the finished cuts longitudinally toward the front.

**Log infeed:** The hydraulic log infeed conveyor transports the wood to the log loader. Several logs can be loaded onto the conveyor at the same time.

