

SINGLE BLADE EDGER

# EB 110

**Exact cut:** The plank remains stationary on the table, while the sawhead travels back and forth.

**Optimum yield:** The un-edged plank is aligned at the zero line and the splinters are removed.

**Maximum feed:** The one-man operated, longitudinal cut circular saw allows an infinite adjustment of the feeding rate to respectively suit the various plank thicknesses.

**Parallel cut:** After the initial cut, the plank is turned around and, with the aid of the adjustable fence, is cut then parallel in accordance with the required size. This parallel fence can be folded down to one side. Thus, large boards can also be processed.

Additional side fences facilitate slat cutting.



## EB110

Max. cutting length	4,400 – 5,200 – 6,200 mm
Max. cutting height	110 mm (optional 135 mm)
Electric motor	5.5 KW (optional 7.5 KW)
Feed	hydromechanical continuously
Weight	600 – 900 kg
Optional	Laser guide Suction channel Automatic positioning parallel fence Pressure beam



DB 65 . DB 90 . EB 110



**RESCH & B** THE MACHINE COMPANY SINCE 1955

RESCH & B GMBH

I-39053 Blumau (South Tyrol) - Brennerstraße 44/a - T +39 0471 35 31 37 - F +39 0471 35 31 77 - [info@resch-3.com](mailto:info@resch-3.com) - [www.resch-3.com](http://www.resch-3.com)

# DB 65 . DB 90

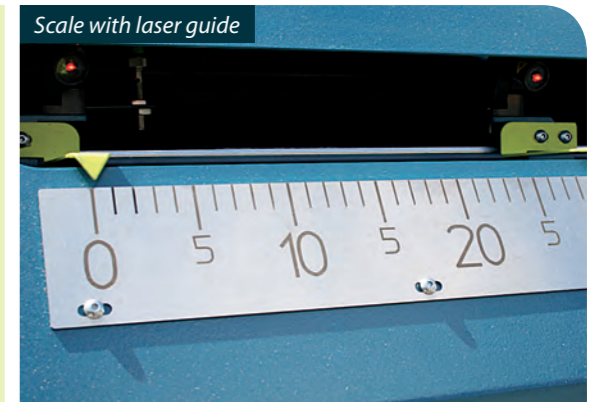

Typ	DB 65	DB 90	
<b>S</b> Max. passage height	65	90	mm
Max. passage width	850	850	mm
<b>B</b> Sawhead width	1,400	1,535	mm
* Standard cutting lengths	4.4 – 5.2 – 6.2	4.4 – 5.2 – 6.2	m
Max. distance of saw blades	500	500	mm
Min. distance of saw blades	40	40	mm
Saw blade diameter	300	350	mm
Feeding rate	0 – 90	0 – 90	m/min
Electric motor of circular saw blade	2 x 4.6	2 x 7.5	KW
Total weight	1,500	1,800	kg

\* Special lengths available on request

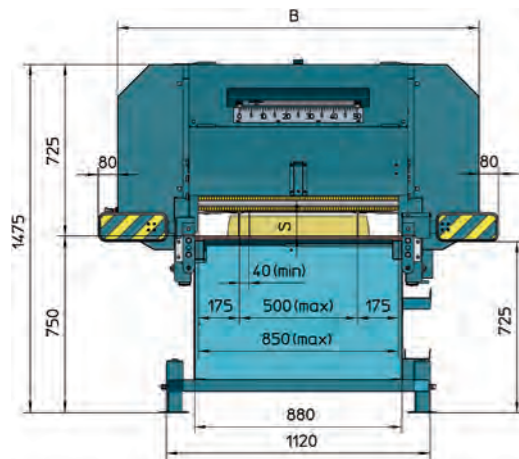

**High precision:** The plank remains stationary on the table, while the saw-head travels back and forth. Two pressure rollers in front and behind of the saw blades hold the wood in place with downward pressure during the cutting process. This new manufacturing process is unique to the market and guarantees an exact, parallel and straight cut.

**Space-saving:** The plank remains stationary on the table and is not pushed through longitudinally.

**Maximum efficiency:** The power consumption of the circular saw motors is constantly monitored and automatically adjusted to the optimum feeding rate.

**Easy operation:** Each individual plank is aligned using cross chains at the zero line by means of a laser guide. The second movable saw blade is subsequently adjusted to ensure that the maximum yield is achieved. A desired measurement can also be set at the control panel. The lateral fence, adjustable from 3 to 16cm, facilitate slat cutting.

**One-Man operation:** The infeed and discharge is performed from laterally and is operated by only one person. The operation of conventional double edgers, in which the plank needs to be pushed through, requires one person at the infeed end and another at the outfeed end.

**No suction unit is required:** Due to the rotation speed of the saw blade, the wood shavings and sawdust are propelled into a collection box. This box is emptied every time the end position is reached.

# DB 65 . DB 90

