

Bond | Protect | Beautify

With our manual guns, automatic and robotic applicators, supplied by our wide range of pumps & machines for fluid handling, dosing, mixing & dispensing.

SAMES KREMLIN provides industrial solutions for production increase, quality improvement, material & cost savings.

We are designers and manufacturers of process equipment that is divided into 6 ranges:

Airspray: Since 1925, we have been an Airspray manufacturer bringing you the very best in finishing.

Airmix®: Creator of Airmix® Technology since 1975, we provide the perfect mix between quality and productivity.

Airless: We provide premium Airless Products for finishers with demanding applications.

REXSON Dispense: Pumping beyond possible, dispensing precisely.

Electrostatic liquid: expertise for high finishing quality & efficiency.

Powder: Powder coating solutions for the highest Productivity since 1960.

FIND YOUR LOCAL CONTACT BY FLASHCODE:



www.sames-kremlin.com





Apply your Skills

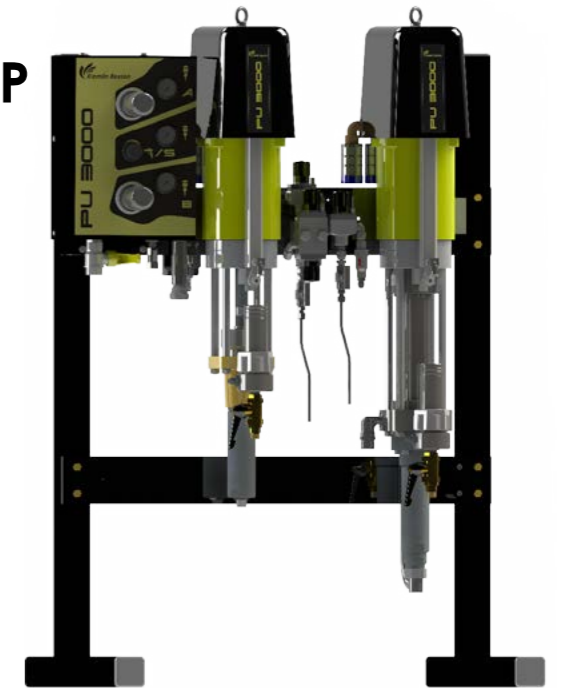

AIRSPRAY/AIRMIX®/AIRLESS PU3000 PLURAL COMPONENT MIXING & DOSING PAINT PUMP



-  User friendly
-  Material mixing quality
-  Security of application

Related Technologies



Apply your Skills

www.sames-kremlin.com

1703.573.646.002 - SAMES KREMLIN reserves right to change without notice characteristics and services offered as well as equipment and attachments of these.

MECATRONIC DOSING PU 3000



injectmix

PfE

FLOWMAX
TECHNOLOGY

TECHNICAL DATA

	PU 3000 HTI, HPA, HTV LOW PRESSURE	PU 3000 MEDIUM PRESSURE	PU 3000 HIGH PRESSURE
Gun	Airspray	AIRMIX®	AIRMIX®/AIRLESS
Pressure ratio	1/1	30/1	53/1
Maximum fluid pressure (bar)	6	200	350
Power supply	115/230V-100W		
Maximum air inlet pressure (bar)	6		
Product viscosity (cps)	30-8000		< 20 000
Mixing accuracy (%)	± 1		
Mixed fluid output (cc/mn)	10 - 4 000		
Mixing ratio	1/1 - 20/1		
Fluid passages	Stainless steel, carbide and PEHD		

PU 3000: DOSING AND MIXING QUALITY

Mecatronical dosing equipment, innovative and patented solution, PU 3000 includes pumping, metering and electronic (Plug & Spray).

Its intuitive use requires few learning. The PULSE FREE ELECTRONIC CONTROL (PFE) SAME'S KREMLIN patent, an innovation in the control of pump change over is the only one in the world which prevents any lack of product during injection - base or catalyst - which might alter the quality of dosing. It also allows to follow in real time the ratio - WYSIWYG - the displayed ratio is the real ratio.

The injectmix system allows to inject a customizable catalyst volume in a continuous flow of base - directly in a very high performance mixer which guarantees the mixing quality. The FLOWMAX® technology - fluid section with sealing made with a bellow - used on the catalyst side prevents its crystallization.

The electronic technology alerts if needed and constantly monitors the actual material consumption of products and calculates the VOC's.

* WYSIWYG: What You See Is What You Get

MATERIALS HANDLED

Primers, finish / high gloss, moisture-sensitive materials, anti-corrosion materials, abrasive materials, solvent or water-based materials, adhesives. Single or bi-component materials.

RECOMMENDED MARKETS



ROLLING
EQUIPMENT



MACHINE TOOLS



RENEWABLE
ENERGIES

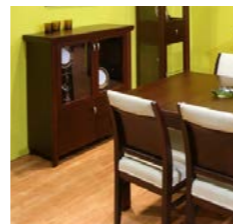

FURNITURE

CUSTOMER BENEFITS

- ➔ Lower cost of ownership for fast R.O.I. (return on investment)
 - ▶ Control and reduction of material consumption and COV's
 - ▶ Accurate mixing and dosing (no part touch-up)
 - ▶ Volume of flushing solvent limited to real mixed material
 - ▶ Low labor time thanks to simplicity of use
- ➔ Can be used with single or bi-component materials (charged paints, anti-corrosion, zinc, glues ...)

USER FRIENDLY

- Quick start-up
- Automatic component management : base, catalyst and solvent.
- Programmable flushing priming & regeneration.
- Intuitive and user-friendly machine/operator interface
- Fast operator learning
- Preventive maintenance alarm



QUALITY OF MIXED MATERIAL

- Constant fluid flow rate thanks to KREMLIN REXSON PULSE FREE ELECTRONIC CONTROL (PFE).
- Unsurpassed ± 1% mixing accuracy thanks to innovative pump change over technology.
- Continuous mixing auto-adjustment.



APPLICATION SECURITY

- Product filter delivered in standard
- Stainless steel fluid passages for water-based materials.
- High injection reliability thanks to PULSE FREE ELECTRONIC CONTROL (PFE).

PRODUCTION EFFICIENCY

- Design without flowmeter preventing any production stop
- For moisture sensitive materials: total sealing done by a FLOWMAX® bellow on the catalyst side on PU 3000 low and medium pressure versions.

QUALITY OF MIXED MATERIALS

- Perfect mixing : direct injection in the high performance static mixer
- Always fresh materials on demand
- Unique design of the inline static mixer.

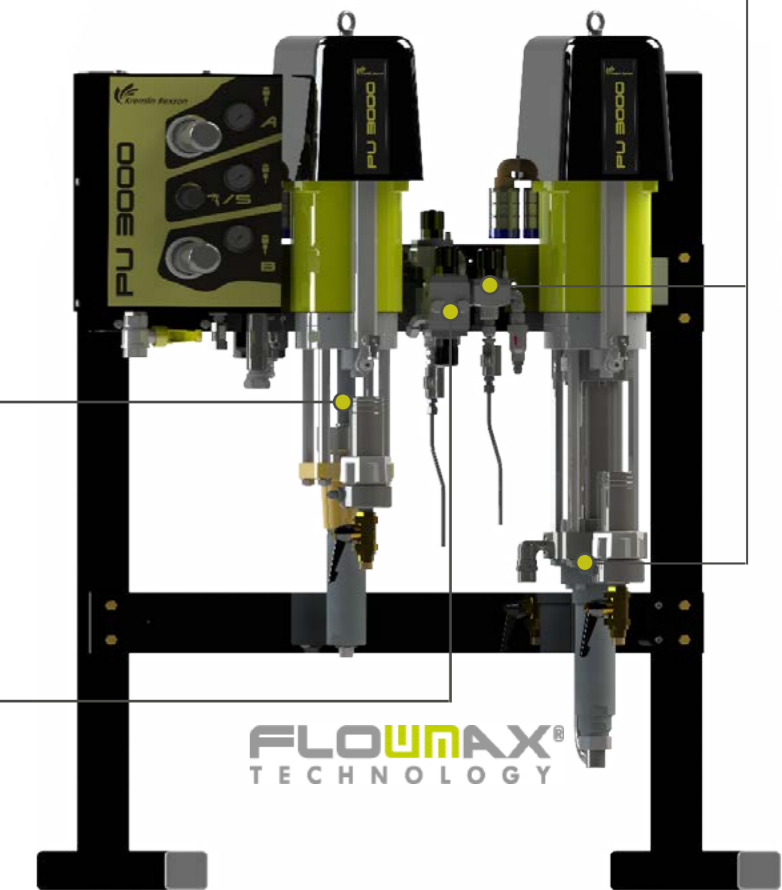

FLOWMAX
TECHNOLOGY

SAMES KREMLIN

www.sames-kremlin.com