

## Travelling Screw

For large storage volumes in the wood-working industry and for power station applications.

### Design characteristics

- solid, robust construction
- drive unit freely accessible

### Applications

- for rectangular silos with large storage volumes

### Customer advantages

- emergency emptying with parked travelling screw
- bulk material will be discharged over its full length
- easy to maintain

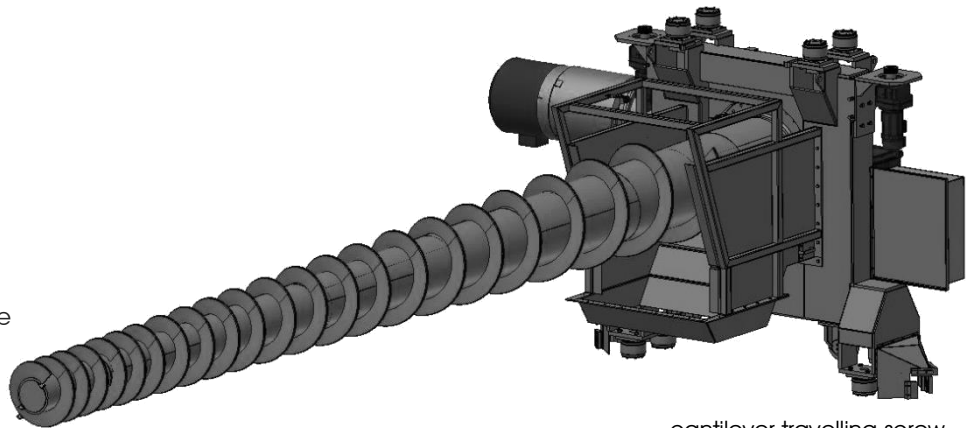

cantilever travelling screw

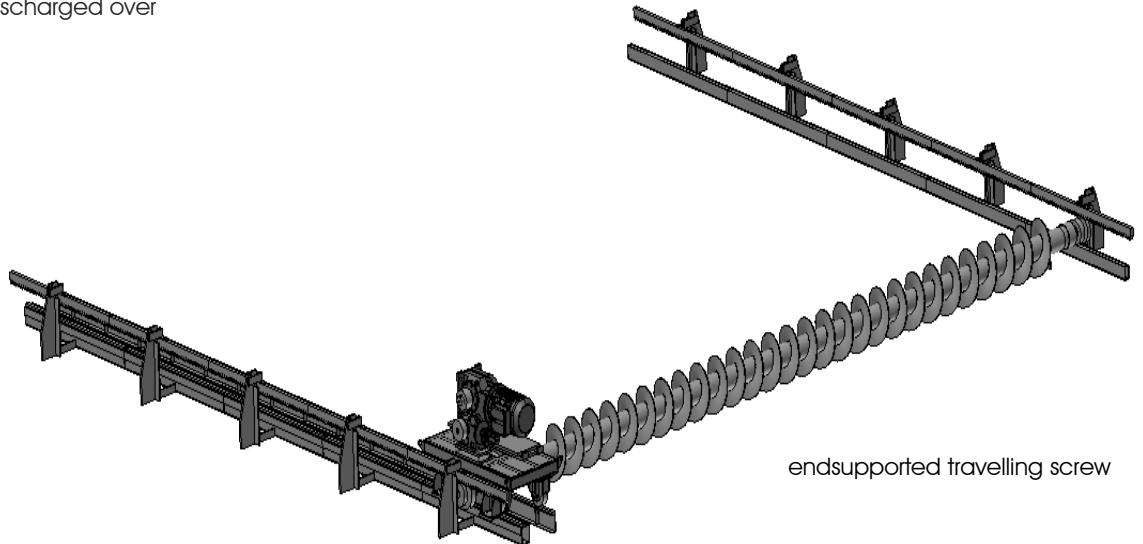

endsupported travelling screw

Technical data	
• discharge capacity	50 up to 600 m <sup>3</sup> /h
• driving power	30 up to 315 kW
• dimensions	
width – supported both sides	10.000 up to 15.000 mm
width – supported one-sided	7.000 up to 13.000 mm
filling height	8.000 up to 30.000 mm
length	20.000 – 100.000 mm (other sizes are available)
• controls	route position
• wear protection	as an option, specially tailored to the application and the bulk material, for example different stainless steels, Hardox, wear protection welding, Infinite Shield (ceramic)
• execution	CE declaration of conformity ATEX: standard no ex-qualification Alternatives: inside: zone 22 and outside: no zone (Ex II 3/-D)