

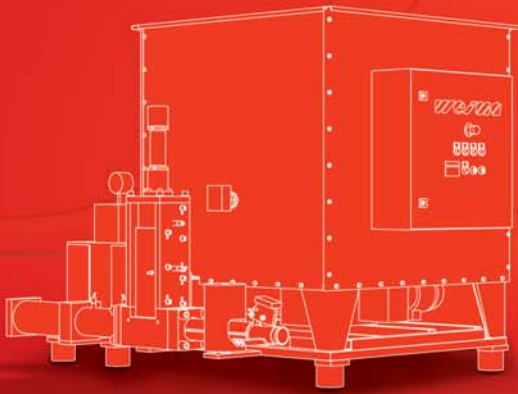

zerkleinern + brikettieren



BRIKETTIERPRESSEN KOMPAKT-SERIE

BAUREIHE C 150 | C 160 | C 170



www.weima.com

PRESST IHREN ABFALL ZU BRIKETTTS.



DIE ETABLIERTE BAUREIHE C 150 | C 160 | C 170
BRIKETTIERT WERKSTOFFE ALLER ART.



HYDRAULIK MIT SEPARATEM ÖLTANK

→ Temperaturüberwachte Hydraulikeinheit
// Komplette Ventilsteuerung // Pumpen-
motor für lange Laufzeiten



ENDLAGENGEDÄMPFTER ZYLINDER

→ Geschraubter Deckel // Wartungsfreier
Ablauf



VORVERDICHTER

→ Geschlossen // Staubdicht



PRESSRAUM- VERSCHLEISSBUCHSE

→ Verhindert Verschleiß im Pressbereich

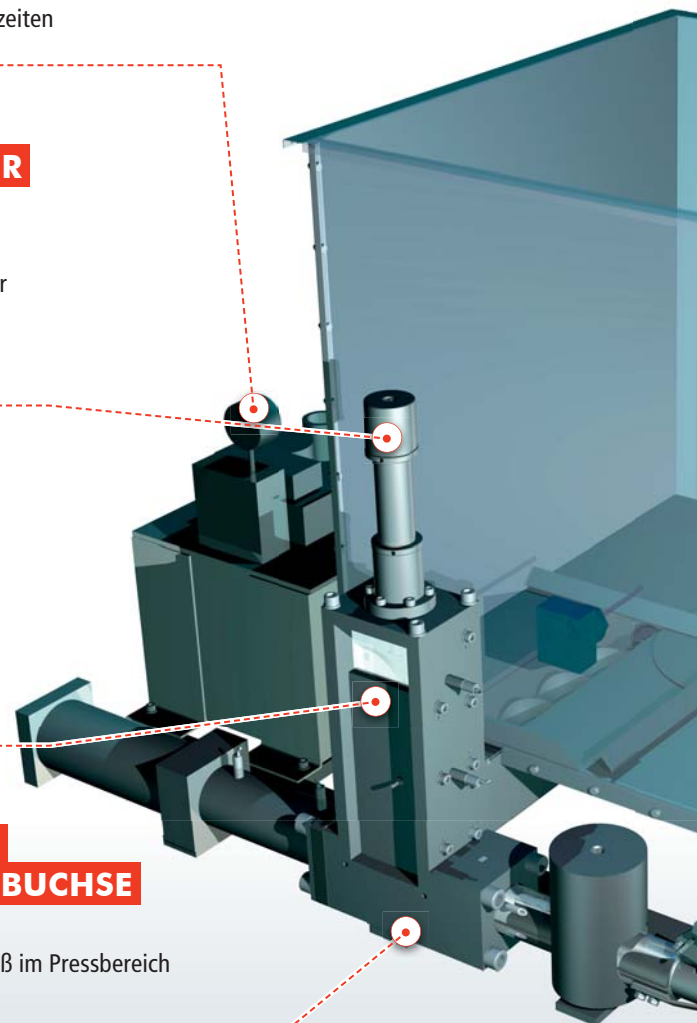



SPÄNEBEHÄLTER

→ Mit Rührwerk und Austragschnecke



SPS-STEUERUNG

→ Handschaltung für manuelles Freifahren der Maschine // Internationale Normteile



STABILER GRUNDRAHMEN

→ Extrem niedrige Bauhöhe // Robustes Grundgestell // Auf Gummifüßen



BRIKETTLÄNGEN- ÜBERWACHUNG

→ Regelt die Länge des Briketts auf ein gleiches Maß



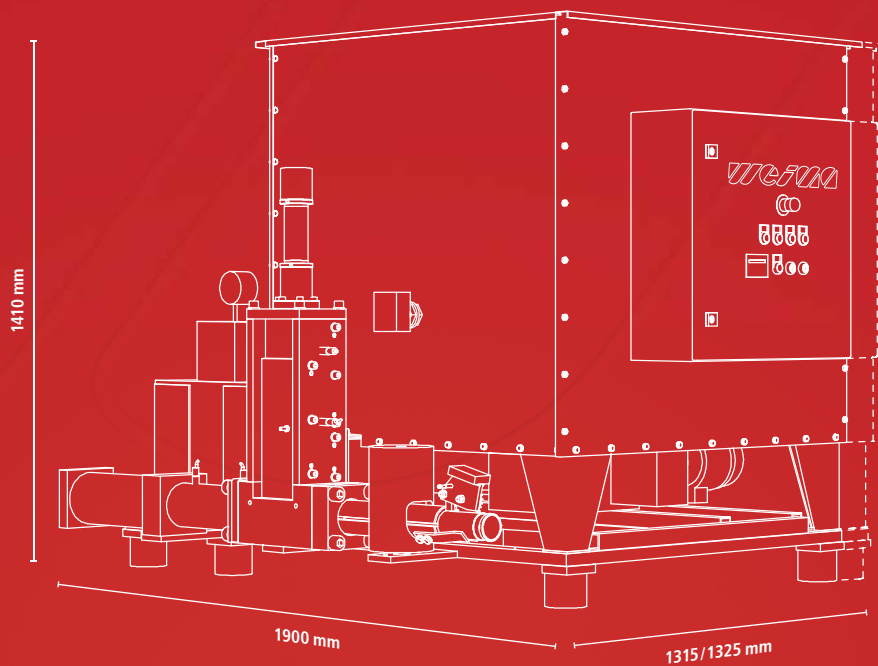

TECHNISCHE DATEN		C 150	C 160	C 170
Brikettdurchmesser	[mm]	50	60	70
Durchsatzleistung	[kg/h]	bis 50*	bis 60*	bis 80*
Hydraulikmotor	[kW]	5,5	5,5	7,5
Hydraulik-Ölmenge	[l]	100	100	100
Gewicht	[ca. kg]	800	850	900

* Die Durchsatzleistung ist materialabhängig. Angegeben sind Durchschnittswerte.
Brikettiert werden können z.B Holz, Styropor, Schaumstoffe, oder Papier (Voraussetzung: Material-Restfeuchte ≤ 18%).

