



Horizontal slot and mortising machine

Horizontal slot and mortising machine Model 116



4-way split grid roller (16, 22, 25, 32), dowel boring device for fast creation of rows of holes.



Fence for frames to insert with 2 manual eccentric clamps

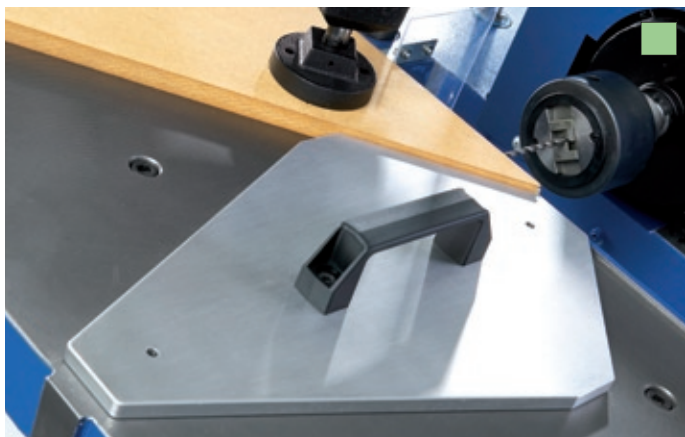

Mitre fence for fix degrees 45° / 22,5°



Work piece fence up to 1500 mm long, freely adjustable

Highest precision through quality workmanship.

Machine base in a modern, elegant steel construction. Work table and cross table in thick-walled, heavily ribbed and torsion-resistant cast iron performance, CNC manufactured. Cross support with adjustable ball bearing guides.

Features such as work piece fence, fence for frame, mitre fence, dowel boring device, displacement device, two eccentric clamps are part of the standard equipment.





■ = Series ■ = Optional



Adjustable fence for double angle, freely adjustable 22.5 - 75°



One hand lever operation with remote locking of the dowel boring device for comfortable working

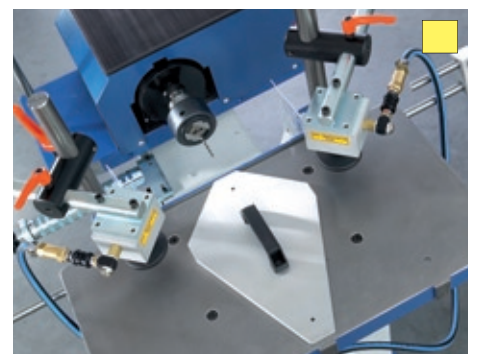

Pneumatic clamping cylinder with manual sliding valve on the cylinder



Counter in hand wheel for height adjustment, partition 0.1 mm

Horizontal slot and mortising machine Model 116 Technical details

| | |
|-----------------------|----------------|
| • Tabletop height | 910 mm |
| • Tabletop size | 700 x 380 mm |
| • Max. drilling depth | 145 mm |
| • Max. length of slot | 240 mm |
| • Vertical setting | 135 mm |
| • Motor | 1,5 kW (2HP)* |
| • Voltage | 400 V / 50 Hz |
| • Speed | 3000 rpm |
| • Space requirement | 1600 x 2350 mm |
| • Net weight | 200 kg |

* optional:
pole-changing motor with 2 speeds 1500/3000 rpm (1.3/1.7 kW)

The Technology

- Suction hood 100 mm \varnothing
- Dowel boring device 16, 22, 25, 32 mm with precision grid roller
- Displacement device
- Mitre fence for fix degrees 45°/22,5°
- Fence for frames to insert
- Work piece fence to 1500 mm for series processing
- Tool rack
- Motor protection on / off switch (lockable emergency-stop) integrated in the cover (motor cover)
- Automatic motor brake
- Two-jaw chuck clamping range 1-20 mm, with protective sleeve
- 2 manual eccentric clamps

Other designs on request.
Subject to technical alterations.

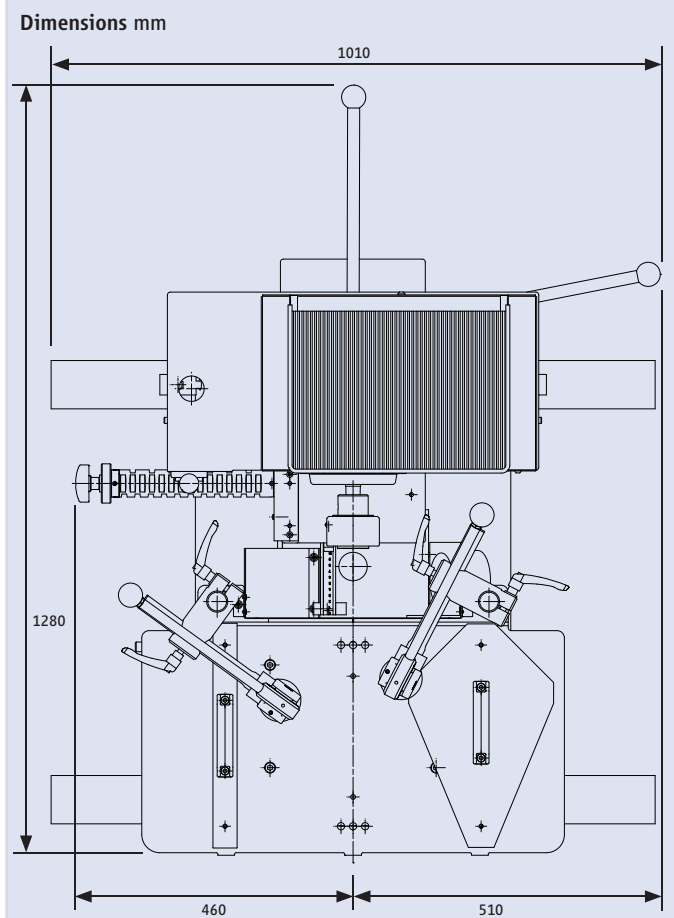

The images also show special accessories that are not part of the standard scope of delivery. Basic equipment according to valid price list.

Drilling

Sawing

Cutting

Planing

HOKUBEMA

HOKUBEMA
Maschinenbau GmbH

Anton-Günther-Straße 3 - 7
D-72488 Sigmaringen

Phone +49 (0)7571 755-0 www.hokubema-panhans.de
Fax +49 (0)7571 755-222 info@hokubema-panhans.de