

1

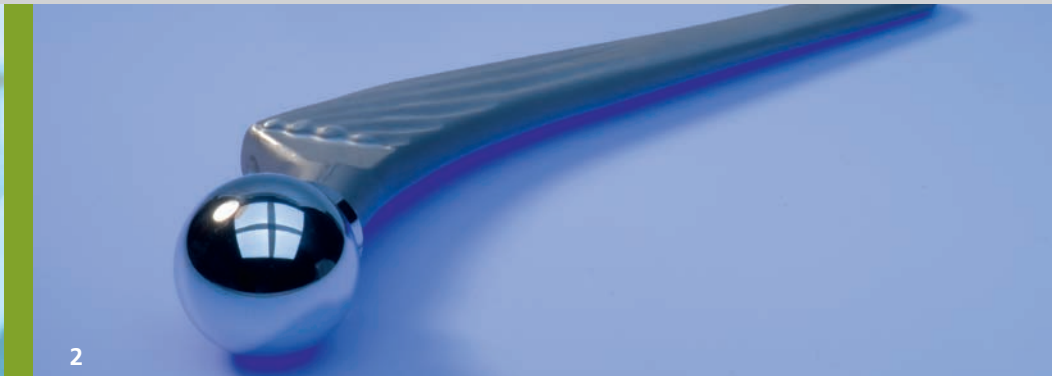

2

1 Syringe nest in sterile pharmaceutical packaging

2 Hip implant

STERILIZATION DISINFECTION WITH ACCELERATED ELECTRONS

Fraunhofer Institute for Organic Electronics, Electron Beam and Plasma Technology FEP

Winterbergstr. 28
01277 Dresden, Germany

Contact persons

Dr. Gaby Gotzmann
Phone +49 351 2586-353
gaby.gotzmann@fep.fraunhofer.de

Javier Portillo
Phone +49 351 2586-591
javier.portillo@fep.fraunhofer.de

www.fep.fraunhofer.de

The Fraunhofer FEP has used electron beams for many years to induce controlled chemical and biological effects on material surfaces. One already established process is seed treatment using a beam of low-energy electrons, resulting in destruction of the DNA of harmful microorganisms.

Low-energy electrons also allow the surfaces of medical products (implants, instruments), packaging, and foods and animals feeds to be sterilized or disinfected. Even sensitive materials and products can be effectively disinfected or sterilized within a short time (milliseconds up to seconds) using this environmentally friendly and gentle technology.

The materials and products can be processed at atmospheric pressure and maintain their shape stability and product-specific properties. The electron beam can also penetrate packaging and sterilize the whole product, so making sterilization processes much simpler.

In contrast to other sterilization methods, which use radiation, sterilization/disinfection using low-energy electrons (up to max. 300 keV) only requires a simple, local radiation shield. This means that the equipment is compact and can be easily integrated in-line into existing process chains. A portable system is also conceivable and such a system has been successfully used to treat seeds.

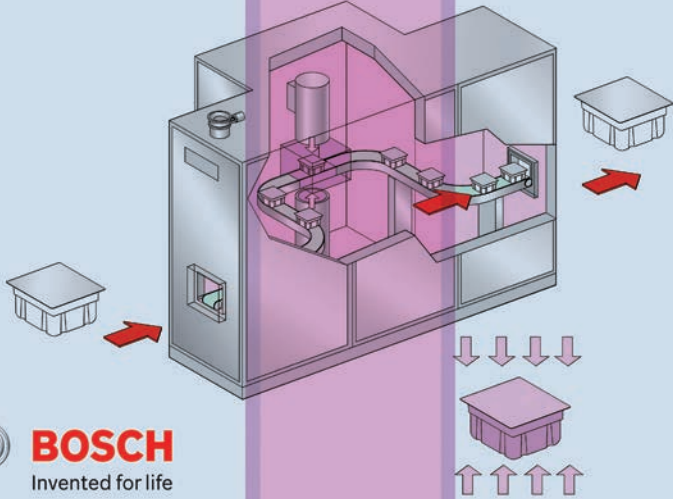

BOSCH
Invented for life
3



4

Applications

Sterilization:

- packaging materials and packaging systems
- web materials
- fluids
- implants and surgical materials
- medical instruments and equipment
- pharmaceutical raw materials
- single-use articles
- natural products
- partial sterilization using miniature unit

Disinfection and pathogen destruction:

- seeds of cereal crops and vegetables
- foods such as cereals, herbs/spices, fruit and, eggs
- plants and parts of plants
- destruction of microbes in solid and liquid waste

Properties

- sterile surfaces
- sterile interfaces
- sterile products
- disinfected products

Our offer

- sterilization or disinfection using low-energy electrons, gas plasmas and UVC beams
- very suitable for sensitive products and materials such as plastics, organic materials and fabrics with/without multilayers, ceramics, textiles, and electronic components
- reduced corrosion and abrasion
- maintenance of shape stability and product-specific properties
- processing times ranging from a few milliseconds to several seconds
- compact units suitable for in-line use or batch systems
- can be integrated into existing systems
- fully electronic in-line process control
- qualification and validation using recognized microbiological tests
- processes which meet the highest standards (FDA, DIN ISO 11137)
- low costs for large product quantities

Process scheme for electron beam sterilization

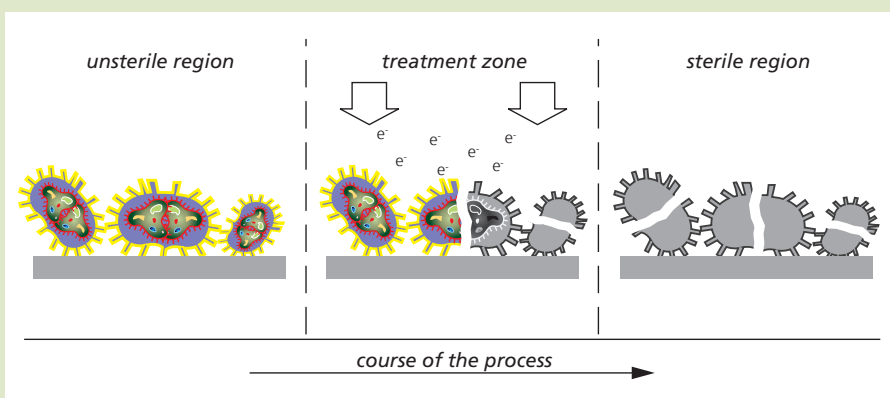

- 3 In-line sterilization process
(© Robert Bosch GmbH)
- 4 Ceramic implants



We focus on quality
and the ISO 9001.